

**WATER HEATER**  
RANGE 2025

**HAVELLS**



**ENGINEERED FOR  
HARD WATER**

**FASTER | SAFER | SAVES**

# WHY HAVELLS WATER HEATER?



***FASTER***



***SAFER***



***SAVES***



***LONG LIFE***

# FASTER

Havells water heaters saves your precious time with fast heating. With Less wait time – enjoy the convenience of hot water whenever you need it.



## MAGNATRON WATER HEATER

10 min - 12 min or 25% faster heating in Magnatron Water Heater because of patented induction technology. No Heating element inside water Heater, Minimal scaling and uniform heating throughout life of water Heater.



## 3-IN-1 CONVERTIBLE DUAL ELEMENT WATER HEATER

33% faster heating in Dual element Water heater because of 2 heating elements. 3 Heating models of 1 kW, 2 kW and 3 kW. For faster Heating water heater can be operated at 3 kW.



## INCOLOY GLASS COATED HEATING ELEMENT

Incoloy glass coated heating element resist corrosion against extreme hard water conditions & helps in providing superior & fast heating with minimal scaling.



## MCOLOY HEATING ELEMENT

Mcoloy Heating element provides quick heating and high performance with its excellent heat transfer ability and enhanced durability.

# SAFER

Safety is paramount when it comes to water heaters. A safe water heater protects you and your family from potential hazards like overheating, electrical issues, and scalding. Peace of mind comes from knowing Havells water heater is designed with top-notch safety features.



## SHOCK SAFE PLUG\*

India's first integrated shock safe plug is designed to prevent injury to humans due to electric shocks, the plug will cut off the power immediately in case of any current leakage.



## 0.8 MPa HIGH WORKING PRESSURE

Suitable for high rise buildings. The multi function valve prevents pressure to increase beyond 8 bar.



## FIRE RETARDANT POWER CORD

It resist ignition and prevents fire spread, ensuring enhanced safety during water heating.



## WATER RESISTANCE AND SPLASH PROOF (IPX4)

Ensures high level of protection for electrical parts from water splashing



## HIGH PRECISION THERMOSTAT & CUT OUT

Controls Water Temperature & Prevents the Water Heater from overheating by activating and deactivating the Heating element



## DUAL SAFETY ADAPTER

Protects against fire and electric shock by ensuring safe current flow.

\*Available in selected models.

# SAVES

Energy efficiency in water heaters translates to significant savings on your Electricity bills. Havells water heater saves energy not only reduces your expenses but also minimizes your environmental footprint, making it a smart and eco-friendly choice.



## MAGNATRON: Rs. 30 000/- SAVING IN 5 YEAR SPAN:

Reduction in heating time by 10 min -12 min because of Induction technology results 25% less yearly electricity consumption. Uniform heating throughout the lifespan of Water Heater because of No Heating element & Minimal scaling further adds to energy saving.



## MAGNATRON PRO: DUAL LED INDICATOR (WARM & HOT):

The Dual LED indicator displays water temperature levels—yellow at 55 °C (warm) and red at 75 °C (hot). Energy can be saved by using warm water if higher temperature isn't needed.



## DUAL ADJUSTABLE KNOBS IN CONVERTIBLE (DUAL ELEMENT) WATER HEATER:

The temperature & Wattage setting knob lets users adjust temperature & power to their comfort level, ensuring personalized warmth and energy-efficient usage

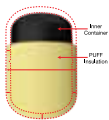

## HIGH DENSITY PUF INSULATION

CFC free thicker PUF insulation offers complete protection against radiant heat loss, reduces energy consumption and provides higher energy efficiency.

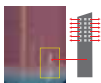

## WHIRLFLOW TECHNOLOGY

It avoids direct contact between cold and hot water flow for a faster heating and optimized energy saving effecting 20% more hot water output.

# LONG LIFE

A durable water heater means fewer replacements and repairs, providing long-term reliability and cost savings. Havells water heater ensures a long lifespan, consistent performance and peace of mind for years to come.



## FEROGLAS COATED INNER CONTAINER

Provides superior corrosion resistance and 'anti-rust property' resulting in longer life compared to standard inner container designs, also able to withstand high pressure up to 8 bar.



## HEAVY DUTY PROTECTIVE ANODE ROD

The tank has an anode rod with a stainless-steel core that is designed to protect the tank from corrosive elements.



***STORAGE  
WATER HEATER***

# MAGNATRON PRIME

## ELECTRIC STORAGE WATER HEATER



NEW

Saves  
**Rs. 30 000/-**  
IN 5 YEAR SPAN

Patented  
**Technology**

**25%\***  
FASTER  
HEATING

CAPACITY : 15 L & 25 L

COLOR : WHITE BLUE



**2** YEAR  
COMPREHENSIVE  
WARRANTY

**5** YEAR WARRANTY  
ON INDUCTION  
COIL

**7** YEAR PRODUCT  
REPLACEMENT  
WARRANTY\*

### FASTER

### SAFER

### SAVES

### LONG LIFE

### SMART

- Induction Technology
- No Heating Element
- 25% Energy Saving
- Ferroglas Coated Inner Container
- Remote control Easy operation
- Scaling Resistant
- Dry Heat Protection
- High Density PUF Insulation
- Heavy Duty Protective Anode Rod
- Smart Mode Setting
- Fire Retardant Power Cord
- Whirlflow Technology
- Long lasting Heating efficiency
- Eco Mode
- High Working Pressure 0.8 MPa
- Digital Temperature Display
- Dual Safety Adapter

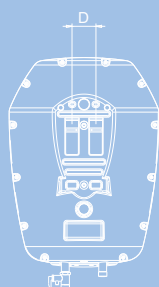
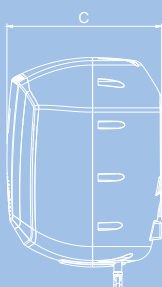
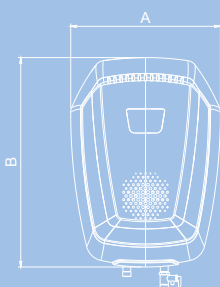

Model	A	B	C	D
Magnatron Prime 15 L	380 mm	501 mm	374 mm	62 mm
Magnatron Prime 25 L	400 mm	560 mm	413 mm	62 mm

# MAGNATRON PRO

## ELECTRIC STORAGE WATER HEATER



NEW



Saves  
**Rs. 30 000/-**  
IN 5 YEAR SPAN



Patented  
**Technology**

**25%\***  
**FASTER  
HEATING**

CAPACITY : 15 L & 25 L

COLOR : WHITE BLUE



**2**

YEAR  
COMPREHENSIVE  
WARRANTY

**5**

YEAR WARRANTY  
ON INDUCATION  
COIL

**7**

YEAR PRODUCT  
REPLACEMENT  
WARRANTY\*

### FASTER



Induction  
Technology



No Heating  
Element



25%  
Energy Saving



Ferroglass  
Coated Inner  
Container



Scaling  
Resistant



Dry Heat  
Protection



Dual LED Indicator  
(Warm & Hot)



Heavy Duty  
Protective  
Anode Rod



Fire Retardant  
Power Cord



High Density PUF  
Insulation



Long lasting  
Heating  
efficiency



High Working  
Pressure  
0.8 MPa



Whirlflow  
Technology

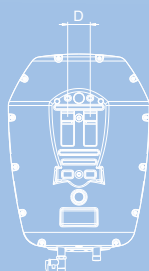
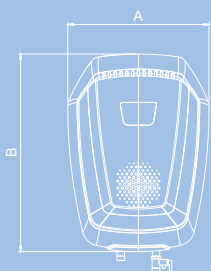

Model	A	B	C	D
Magnatron Pro 15 L	380 mm	501 mm	374 mm	62 mm
Magnatron Pro 25 L	400 mm	560 mm	413 mm	62 mm

**ENGINEERED FOR HARD WATER**

\*In case of Tank Leakage.

NEW

CONVERTIBLE WATER HEATER



WITH 3 HEATING MODES  
1 kW | 2 kW | 3 kW

33%  
FASTER  
HEATING

CAPACITY : 10 L, 15 L & 25 L    COLOR : WHITE BLUE



**2** YEAR  
COMPREHENSIVE  
WARRANTY

**5** YEAR WARRANTY  
ON HEATING  
ELEMENT

**7** YEAR PRODUCT  
REPLACEMENT  
WARRANTY\*

### FASTER

### SAFER

### SAVES

### LONG LIFE



Dual Element With  
3 Heating Modes



Shock Safe  
Plug



High  
Density PUF  
Insulation



Ferroglass Coated  
Inner Container



Incoloy Glass  
Coated Heating  
Element



Fire Retardant  
Power Cord



Whirlflow  
Technology



Heavy Duty  
Protective  
Anode Rod



High Working  
Pressure  
0.8 MPa



Dual  
Adjustable  
Knobs



Dual Safety  
Adapter

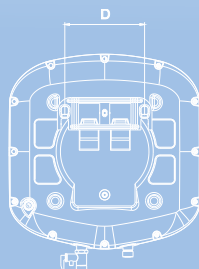
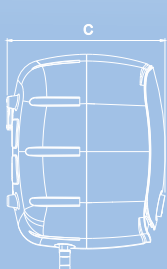
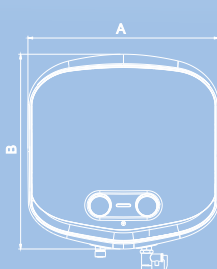

Model	A	B	C	D
BIANCA+ 10 L	412 mm	420 mm	271 mm	172 mm
BIANCA+ 15 L	412 mm	420 mm	340 mm	172 mm
BIANCA+ 25 L	466 mm	476 mm	377 mm	172 mm

# ORAZIO<sup>+</sup>

## Dual Element

ELECTRIC STORAGE WATER HEATER

NEW

CONVERTIBLE WATER HEATER

WITH 3 HEATING MODES  
1 kW | 2 kW | 3 kW

33%  
FASTER  
HEATING



CAPACITY : 10 L, 15 L & 25 L

COLOR : WHITE GREY



**2** YEAR  
COMPREHENSIVE  
WARRANTY

**5** YEAR WARRANTY  
ON HEATING  
ELEMENT

**7** YEAR PRODUCT  
REPLACEMENT  
WARRANTY\*

FASTER

SAFER

SAVES

LONG LIFE



Dual Element  
With 3 Heating  
Modes



Fire Retardant  
Power Cord



High Density  
PUF Insulation



Ferroglass Coated  
Inner Container



Incoloy Glass  
Coated Heating  
Element



High Working  
Pressure  
0.8 MPa



Whirlflow  
Technology



Heavy Duty  
Protective  
Anode Rod



High Precision  
Thermostat &  
Cut Out



Dual Adjustable  
Knobs



Dual Safety  
Adapter

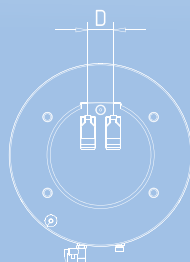
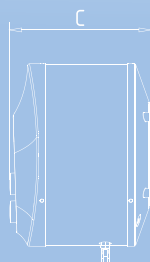
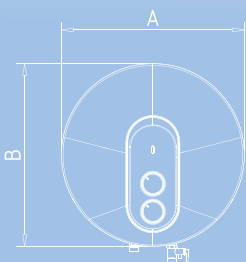

Model	A	B	C	D
ORAZIO <sup>+</sup> 10 L	425 mm	425 mm	289 mm	68 mm
ORAZIO <sup>+</sup> 15 L	425 mm	425 mm	345 mm	68 mm
ORAZIO <sup>+</sup> 25 L	482 mm	482 mm	373 mm	68 mm

ENGINEERED FOR HARD WATER

\*In case of Tank Leakage.

**NEW**

**CONVERTIBLE WATER HEATER**

WITH 3 HEATING MODES  
1 kW | 2 kW | 3 kW

**33%  
FASTER  
HEATING**



CAPACITY : 10 L, 15 L & 25 L    COLOR : WHITE BLUE



**2**

YEAR  
COMPREHENSIVE  
WARRANTY

**5**

YEAR WARRANTY  
ON HEATING  
ELEMENT

**7**

YEAR PRODUCT  
REPLACEMENT  
WARRANTY\*

**FASTER**

**SAFER**

**SAVES**

**LONG LIFE**



Dual Element With  
3 Heating Modes



Fire Retardant  
Power Cord



High Density  
PUF Insulation



Ferroglass Coated  
Inner Container



Incoloy Glass  
Coated Heating  
Element



High Working  
Pressure 0.8 MPa



Whirlflow  
Technology



Heavy Duty  
Protective  
Anode Rod



High Precision  
Thermostat &  
Cut Out



Dual  
Adjustable  
Knobs



Dual Safety  
Adapter

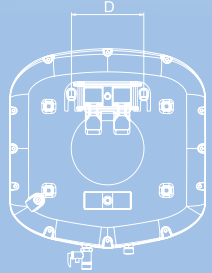
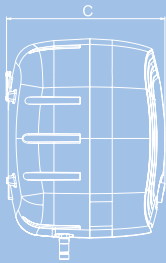
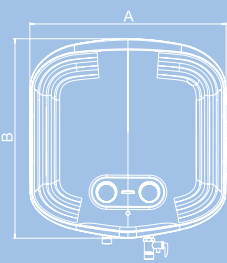

Model	A	B	C	D
VALERIO <sup>+</sup> 10 L	412 mm	420 mm	271 mm	172 mm
VALERIO <sup>+</sup> 15 L	412 mm	420 mm	340 mm	172 mm
VALERIO <sup>+</sup> 25 L	466 mm	476 mm	377 mm	172 mm

# Velora+ Dual Element

## ELECTRIC STORAGE WATER HEATER

**NEW**

**CONVERTIBLE WATER HEATER**

WITH 3 HEATING MODES  
1 kW | 2 kW | 3 kW

**33%  
FASTER  
HEATING**



CAPACITY : 10 L, 15 L & 25 L    COLOR : WHITE BLUE



**2** YEAR COMPREHENSIVE WARRANTY

**5** YEAR WARRANTY ON HEATING ELEMENT

**7** YEAR PRODUCT REPLACEMENT WARRANTY\*

**FASTER**

**SAFER**

**SAVES**

**LONG LIFE**



Dual Element With 3 Heating Modes



Fire Retardant Power Cord



High Density PUF Insulation



Ferroglass Coated Inner Container



Incoloy Glass Coated Heating Element



High Working Pressure 0.8 MPa



Whirlflow Technology



Heavy Duty Protective Anode Rod



High Precision Thermostat & Cut Out



Dual Adjustable Knobs



Dual Safety Adapter

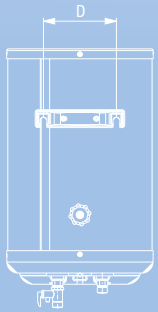
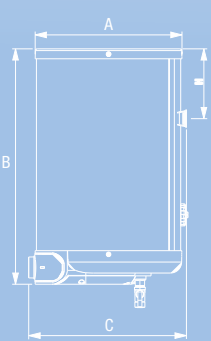

Model	A	B	C	D
VELORA+ 10 L	328 mm	426 mm	352 mm	163 mm
VELORA+ 15 L	328 mm	526 mm	352 mm	163 mm
VELORA+ 25 L	378 mm	564 mm	405 mm	163 mm

**ENGINEERED FOR HARD WATER**

\*In case of Tank Leakage.

**CONVERTIBLE WATER HEATER**

WITH 3 HEATING MODES  
1 kW | 2 kW | 3 kW

**33%  
FASTER  
HEATING**



CAPACITY : 10 L, 15 L & 25 L    COLOR : WHITE BLUE



**2** YEAR COMPREHENSIVE WARRANTY

**5** YEAR WARRANTY ON HEATING ELEMENT

**7** YEAR PRODUCT REPLACEMENT WARRANTY\*

### FASTER

### SAFER

### SAVES

### LONG LIFE



Dual Element With 3 Heating Modes



Fire Retardant Power Cord



High Density PUF Insulation



Ferroglass Coated Inner Container



Incoloy Glass Coated Heating Element



High Working Pressure 0.8 MPa



Whirlflow Technology



Heavy Duty Protective Anode Rod



High Precision Thermostat & Cut Out



Dual Adjustable Knobs



Dual Safety Adapter

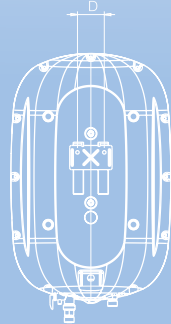
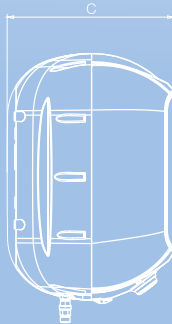
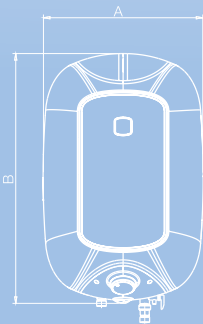

Model	A	B	C	D
PURO <sup>+</sup> 10 L	318 mm	473 mm	304 mm	62 mm
PURO <sup>+</sup> 15 L	329 mm	497 mm	330 mm	62 mm
PURO <sup>+</sup> 25 L	370 mm	578 mm	370 mm	62 mm



CAPACITY : 15 L & 25 L      COLOR : WHITE



**2** YEAR COMPREHENSIVE WARRANTY

**4** YEAR WARRANTY ON HEATING ELEMENT

**7** YEAR PRODUCT REPLACEMENT WARRANTY\*













**FASTER**

**SAFER**

**SAVES**

**LONG LIFE**

**CONVENIENCE**

-  Incoloy Glass Coated Heating Element
-  Shock Safe Plug
-  High Density PUF Insulation
-  Ferroglass Coated Inner Container
-  Patented Temperature sensing LED Indicator
-  Fire Retardant Power Cord
-  Whirlflow Technology
-  Heavy Duty Protective Anode Rod
-  Remote Control Easy operation
-  High Working Pressure 0.8 MPa
-  Digital Temperature display
-  Dual Safety Adapter
-  Feather TouchControl Panel

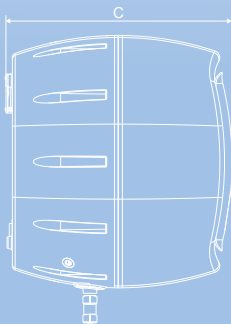
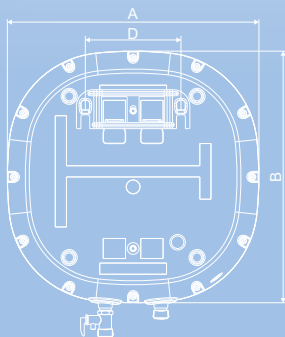

Model	A	B	C	D
ADONIA R 15 L	390 mm	390 mm	358 mm	67 mm
ADONIA R 25 L	453 mm	453 mm	394 mm	67 mm



CAPACITY : 15 L & 25 L    COLOR : WHITE



**2** YEAR COMPREHENSIVE WARRANTY

**4** YEAR WARRANTY ON HEATING ELEMENT

**7** YEAR PRODUCT REPLACEMENT WARRANTY\*

### FASTER

### SAFER

### SAVES

### LONG LIFE

### CONVENIENCE



Incoloy Glass Coated Heating Element



Shock Safe Plug



High Density PUF Insulation



Ferroglass Coated Inner Container



Remote control Easy operation



Fire Retardant Power Cord



Whirlflow Technology



Heavy Duty Protective Anode Rod



Smart Mode Setting



High Working Pressure 0.8 MPa



Eco Mode



Dual Safety Adapter



Digital Temperature Display

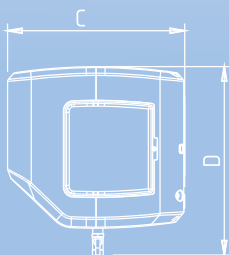
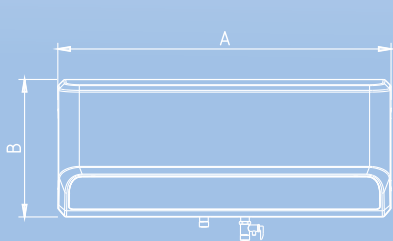

Model	A	B	C	D
ORIZZONTE 15 L	600 mm	330 mm	351 mm	381 mm
ORIZZONTE 25 L	812 mm	335 mm	367 mm	390 mm



CAPACITY : 10 L, 15 L & 25 L

COLOR : SILVER GREY



**2** YEAR COMPREHENSIVE WARRANTY

**4** YEAR WARRANTY ON HEATING ELEMENT

**7** YEAR PRODUCT REPLACEMENT WARRANTY\*

**FASTER**

**SAFER**

**SAVES**

**LONG LIFE**

**CONVENIENCE**



Incoloy Glass Coated Heating Element



Shock Safe Plug



High Density PUF Insulation



Ferroglass Coated Inner Container



Patented Color Changing LED Indicator



Fire Retardant Power Cord



Whirlflow Technology



Heavy Duty Protective Anode Rod



High Working Pressure 0.8 MPa



Temperature setting knob



Dual Safety Adapter

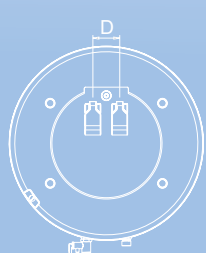
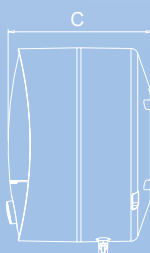
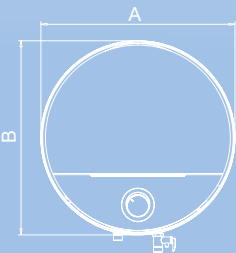

Model	A	B	C	D
OTTO 10 L	427 mm	427 mm	270 mm	68 mm
OTTO 15 L	427 mm	427 mm	328 mm	68 mm
OTTO 25 L	484 mm	484 mm	360 mm	68 mm



CAPACITY : 10 L, 15 L & 25 L

COLOR : WHITE CHAMPAGNE GOLD



**2** YEAR COMPREHENSIVE WARRANTY

**4** YEAR WARRANTY ON HEATING ELEMENT

**7** YEAR PRODUCT REPLACEMENT WARRANTY\*

FASTER

SAFER

SAVES

LONG LIFE

CONVENIENCE



Incoloy Glass Coated Heating Element



Shock Safe Plug



High Density PUF Insulation



Ferroglass Coated Inner Container



Patented Color Changing LED Indicator



Fire Retardant Power Cord



Whirlflow Technology



Heavy Duty Protective Anode Rod



High Working Pressure 0.8 MPa



Temperature setting knob



Dual Safety Adapter

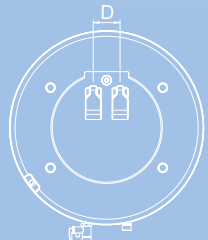
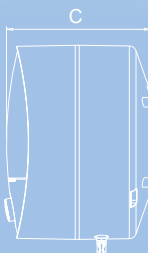
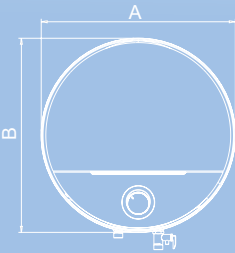

Model	A	B	C	D
OTTO PRIME 10 L	427 mm	427 mm	270 mm	68 mm
OTTO PRIME 15 L	427 mm	427 mm	328 mm	68 mm
OTTO PRIME 25 L	484 mm	484 mm	360 mm	68 mm

# ORAZIO Prime

ELECTRIC STORAGE WATER HEATER



CAPACITY : 10 L, 15 L & 25 L    COLOR : WHITE GREY



**2** YEAR  
COMPREHENSIVE  
WARRANTY

**4** YEAR WARRANTY  
ON HEATING  
ELEMENT

**7** YEAR PRODUCT  
REPLACEMENT  
WARRANTY\*

**FASTER**

**SAFER**

**SAVES**

**LONG LIFE**



Mcoley Heating Element



Fire Retardant Power Cord



High Density PUF Insulation



Ferroglass Coated Inner Container



High Working Pressure 0.8 MPa



Whirlflow Technology



Heavy Duty Protective Anode Rod



High Precision Thermostat & Cut Out



Temperature setting knob



Dual Safety Adapter

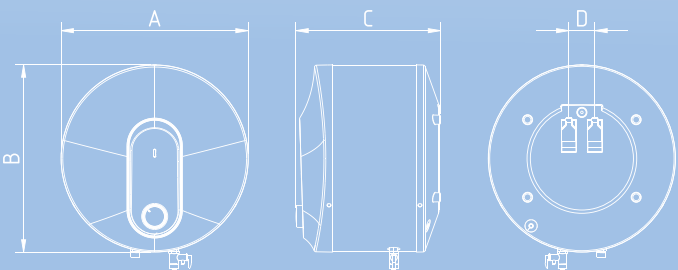

Model	A	B	C	D
ORAZIO PRIME 10 L	425 mm	425 mm	289 mm	68 mm
ORAZIO PRIME 15 L	425 mm	425 mm	345 mm	68 mm
ORAZIO PRIME 25 L	482 mm	482 mm	373 mm	68 mm

**ENGINEERED FOR HARD WATER**

\*In case of Tank Leakage.

# Greta Prime

## ELECTRIC STORAGE WATER HEATER

**NEW**



CAPACITY : 10 L, 15 L & 25 L

COLOR : WHITE BLUE,  
WHITE CHAMPAGNE GOLD



**2** YEAR COMPREHENSIVE WARRANTY

**4** YEAR WARRANTY ON HEATING ELEMENT

**7** YEAR PRODUCT REPLACEMENT WARRANTY\*

### FASTER

### SAFER

### SAVES

### LONG LIFE



Mcoloy Heating Element



Fire Retardant Power Cord



High Density PUF Insulation



Ferroglass Coated Inner Container



High Working Pressure 0.8 MPa



Whirlflow Technology



Heavy Duty Protective Anode Rod



High Precision Thermostat & Cut Out



Temperature setting knob



Dual Safety Adapter

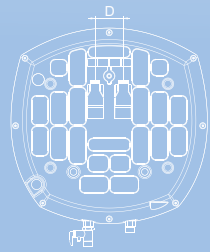
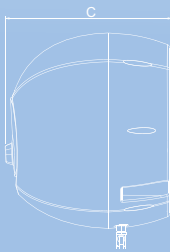
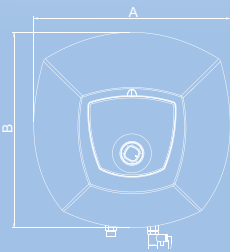

Model	A	B	C	D
GRETA PRIME 10 L	411 mm	410 mm	298 mm	68 mm
GRETA PRIME 15 L	411 mm	410 mm	356 mm	68 mm
GRETA PRIME 25 L	468 mm	466 mm	398 mm	68 mm



CAPACITY : 10 L, 15 L & 25 L    COLOR : WHITE



2 YEAR  
COMPREHENSIVE  
WARRANTY



4 YEAR WARRANTY  
ON HEATING  
ELEMENT



7 YEAR PRODUCT  
REPLACEMENT  
WARRANTY\*

### FASTER

### SAFER

### SAVES

### LONG LIFE



Mcoloy Heating  
Element



Fire Retardant  
Power Cord



High Density  
PUF Insulation



Ferroglass Coated  
Inner Container



High Working  
Pressure  
0.8 MPa



Whirlflow  
Technology



Heavy Duty  
Protective  
Anode Rod



High Precision  
Thermostat &  
Cut Out



Jog Dial Type  
Temperature  
setting Knob



Dual Safety  
Adapter

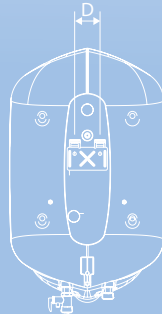
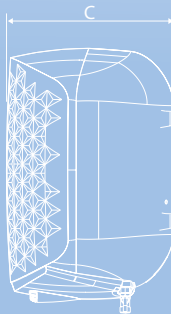
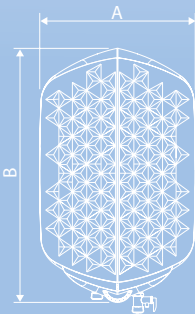

Model	A	B	C	D
PURO NU 10 L	320 mm	384 mm	323 mm	62 mm
PURO NU 15 L	339 mm	526 mm	345 mm	62 mm
PURO NU 25 L	379 mm	620 mm	408 mm	62 mm

# FABIA

## SLIM

ELECTRIC STORAGE WATER HEATER



AVAILABLE IN LH & RH CONFIGURATION

CAPACITY : 10 L, 15 L & 25 L    COLOR : WHITE BLUE



**2** YEAR COMPREHENSIVE WARRANTY

**4** YEAR WARRANTY ON HEATING ELEMENT

**7** YEAR PRODUCT REPLACEMENT WARRANTY\*

### FASTER



Incoloy Glass Coated Heating Element

### SAFER



Fire Retardant Power Cord

### SAVES



High Density PUF Insulation

### LONG LIFE



Ferroglass Coated Inner Container



High Working Pressure 0.8 MPa



Whirlflow Technology



Heavy Duty Protective Anode Rod



High Precision Thermostat & Cut Out



Temperature setting knob



Dual Safety Adapter

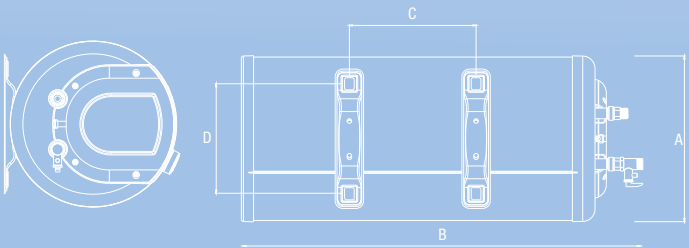

Model	A	B	C	D
FABIA SLIM 10 L	311 mm	425 mm	190 mm	217 mm
FABIA SLIM 15 L	311 mm	555 mm	320 mm	217 mm
FABIA SLIM 25 L	322 mm	720 mm	250 mm	217 mm

# Carlo

ELECTRIC STORAGE WATER HEATER



CAPACITY : 15 L & 25 L

COLOR : WHITE CHAMPAGNE GOLD



2 YEAR COMPREHENSIVE WARRANTY



4 YEAR WARRANTY ON HEATING ELEMENT



7 YEAR PRODUCT REPLACEMENT WARRANTY\*

FASTER

SAFER

SAVES

LONG LIFE

CONVENIENCE



Mcoloy Heating Element



Fire Retardant Power Cord



High Density PUF Insulation



Feroglas Coated Inner Container



Patented Color Changing LED Indicator



High Working Pressure 0.8 MPa



Whirlflow Technology



Heavy Duty Protective Anode Rod



High Precision Thermostat & Cut Out



Dual Safety Adapter

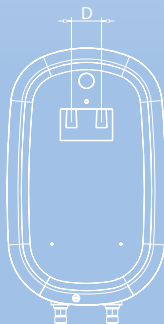
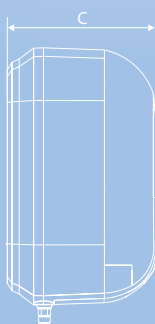
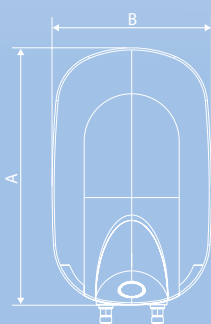

Model	A	B	C	D
CARLO 15 L	498 mm	308 mm	288 mm	65 mm
CARLO 25 L	581 mm	380 mm	340 mm	65 mm

ENGINEERED FOR HARD WATER

\*In case of Tank Leakage.



CAPACITY : 10 L, 15 L & 25 L    COLOR : WHITE BLUE



2 YEAR COMPREHENSIVE WARRANTY



4 YEAR WARRANTY ON HEATING ELEMENT



7 YEAR PRODUCT REPLACEMENT WARRANTY\*

### FASTER

### SAFER

### SAVES

### LONG LIFE



Mcoloy Heating Element



Fire Retardant Power Cord



High Density PUF Insulation



Ferroglass Coated Inner Container



High Working Pressure 0.8 MPa



Whirlflow Technology



Heavy Duty Protective Anode Rod



High Precision Thermostat & Cut Out



Temperature setting knob



Dual Safety Adapter

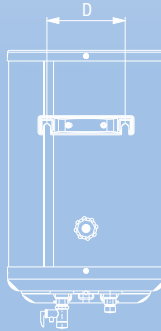
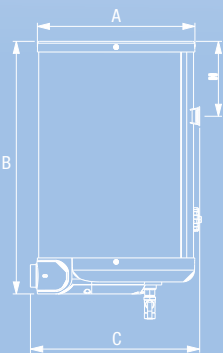

Model	A	B	C	D
VELORA PRIME 10 L	328 mm	426 mm	352 mm	163 mm
VELORA PRIME 15 L	328 mm	526 mm	352 mm	163 mm
VELORA PRIME 25 L	378 mm	564 mm	405 mm	163 mm



CAPACITY : 10 L, 15 L & 25 L      COLOR : WHITE BLUE



**2** YEAR COMPREHENSIVE WARRANTY

**4** YEAR WARRANTY ON HEATING ELEMENT

**7** YEAR PRODUCT REPLACEMENT WARRANTY\*

### FASTER

### SAFER

### SAVES

### LONG LIFE



Mcoloy Heating Element



Fire Retardant Power Cord



High Density PUF Insulation



Ferroglass Coated Inner Container



High Working Pressure 0.8 MPa



Whirlflow Technology



Heavy Duty Protective Anode Rod



High Precision Thermostat & Cut Out



Dual Safety Adapter

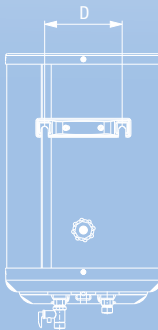
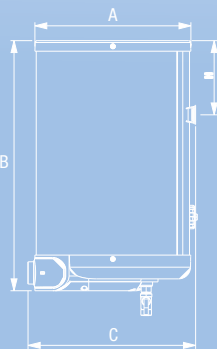

Model	A	B	C	D
VELORA PRO 10 L	328 mm	401 mm	338 mm	163 mm
VELORA PRO 15 L	328 mm	501 mm	338 mm	163 mm
VELORA PRO 25 L	378 mm	553 mm	390 mm	163 mm



CAPACITY : 35 L, 50 L & 100 L    COLOR : WHITE GREY



**2** YEAR  
COMPREHENSIVE  
WARRANTY



**4** YEAR WARRANTY  
ON HEATING  
ELEMENT



**7** YEAR PRODUCT  
REPLACEMENT  
WARRANTY\*

### FASTER



Incoloy Glass  
Coated Heating  
Element



Fire Retardant  
Power Cord



High Density  
PUF Insulation



Ferroglass Coated  
Inner Container



High Working  
Pressure  
0.8 MPa



Whirlflow  
Technology



Heavy Duty  
Protective  
Anode Rod



High Precision  
Thermostat &  
Cut Out



Temperature  
setting knob



Dual Safety  
Adapter

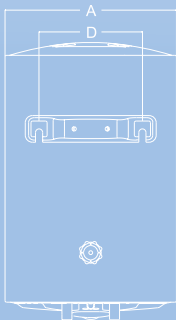
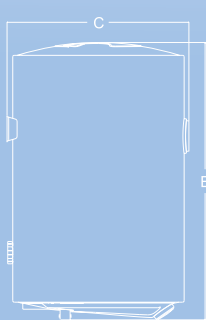

Model	A	B	C	D
MONZA NU 35 L	411 mm	616 mm	435 mm	217 mm
MONZA NU 50 L	461 mm	652 mm	486 mm	217 mm
MONZA NU 100 L	461 mm	1070 mm	486 mm	217 mm

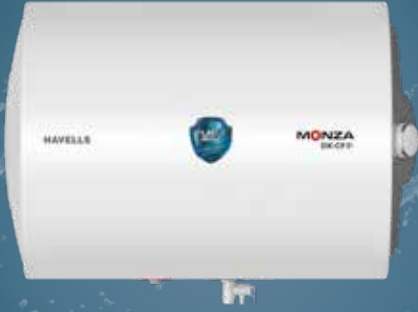

CAPACITY : 50 L    COLOR : WHITE GREY



**2** YEAR COMPREHENSIVE WARRANTY

**4** YEAR WARRANTY ON HEATING ELEMENT

**7** YEAR PRODUCT REPLACEMENT WARRANTY\*

**FASTER**

**SAFER**

**SAVES**

**LONG LIFE**



Incoloy Glass Coated Heating Element



Fire Retardant Power Cord



High Density PUF Insulation



Ferroglass Coated Inner Container



High Working Pressure 0.8 MPa



Whirlflow Technology



Heavy Duty Protective Anode Rod



High Precision Thermostat & Cut Out



Temperature setting knob



Dual Safety Adapter

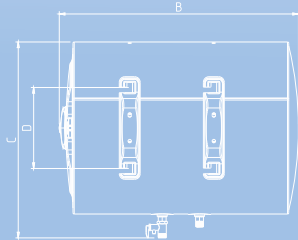
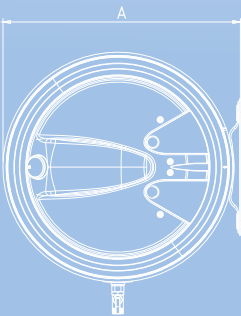

Model	A	B	C	D
MONZA DX CF 50 L	476 mm	600 mm	525 mm	163 mm



CAPACITY : 6 L    COLOR : WHITE BLUE



**2** YEAR COMPREHENSIVE WARRANTY

**4** YEAR WARRANTY ON HEATING ELEMENT

**7** YEAR PRODUCT REPLACEMENT WARRANTY\*

### FASTER

### SAFER

### SAVES

### LONG LIFE



Incoloy Glass Coated Heating Element



Fire Retardant Power Cord



High Density PUF Insulation



Ferroglass Coated Inner Container



High Working Pressure 0.8 MPa



Whirlflow Technology



Heavy Duty Protective Anode Rod



High Precision Thermostat & Cut Out



Temperature setting knob



Dual Safety Adapter

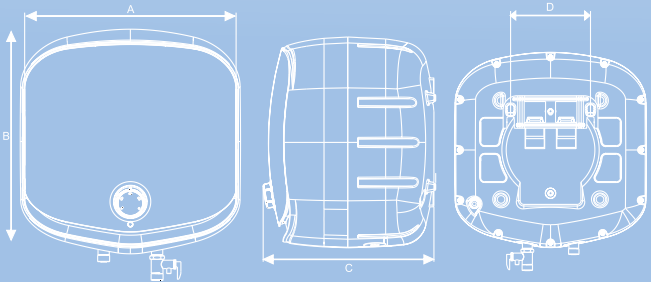

Model	A	B	C	D
BIANCA 6 L	352 mm	344 mm	301 mm	157 mm



CAPACITY : 6 L    COLOR : WHITE BLUE



**2** YEAR COMPREHENSIVE WARRANTY

**4** YEAR WARRANTY ON HEATING ELEMENT

**7** YEAR PRODUCT REPLACEMENT WARRANTY\*

### FASTER



Incoloy Glass Coated Heating Element

### SAFER



Fire Retardant Power Cord

### SAVES



High Density PUF Insulation

### LONG LIFE



Feroglas Coated Inner Container



High Working Pressure 0.8 MPa



Whirlflow Technology



Heavy Duty Protective Anode Rod



High Precision Thermostat & Cut Out



Temperature setting knob



Dual Safety Adapter

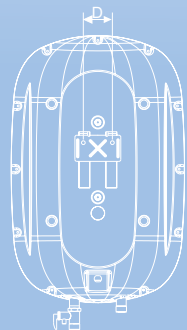
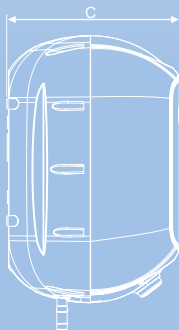
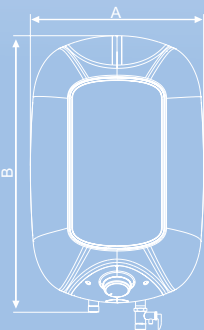

Model	A	B	C	D
PURO 6 L	271 mm	425 mm	258 mm	62 mm



CAPACITY : 6 L

COLOR : WHITE BLUE



**2** YEAR  
COMPREHENSIVE  
WARRANTY



**4** YEAR WARRANTY  
ON HEATING  
ELEMENT



**7** YEAR PRODUCT  
REPLACEMENT  
WARRANTY\*

### FASTER



Incoloy Glass  
Coated Heating  
Element



Fire Retardant  
Power Cord



High Density  
PUF Insulation



Feroglas Coated  
Inner Container



High Working  
Pressure  
0.8 MPa



Whirlflow  
Technology



Heavy Duty  
Protective  
Anode Rod



High Precision  
Thermostat &  
Cut Out



Temperature  
setting knob



Dual Safety  
Adapter

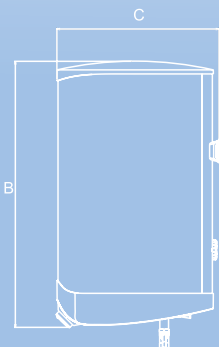
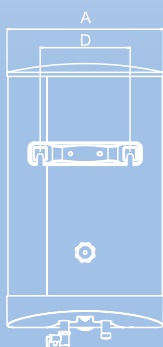

Model	A	B	C	D
FABIA 6 L	259 mm	412 mm	272 mm	163 mm

# Instanio

## Prime

ELECTRIC STORAGE WATER HEATER



CAPACITY : 6 L    COLOR : WHITE BLUE



**2** YEAR COMPREHENSIVE WARRANTY

**4** YEAR WARRANTY ON HEATING ELEMENT

**7** YEAR PRODUCT REPLACEMENT WARRANTY\*

### FASTER

### SAFER

### SAVES

### LONG LIFE



Incoloy Glass Coated Heating Element



Fire Retardant Power Cord



High Density PUF Insulation



Ferroglass Coated Inner Container



High Working Pressure 0.8 MPa



Whirlflow Technology



Heavy Duty Protective Anode Rod



High Precision Thermostat & Cut Out



Dual Safety Adapter

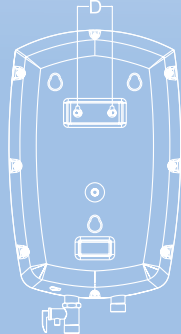
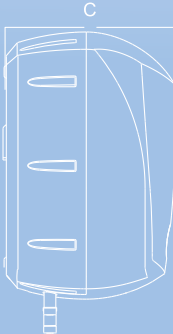
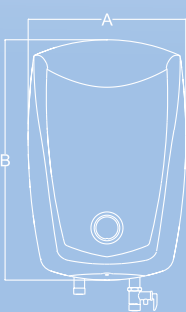

Model	A	B	C	D
INSTANIO PRIME 6 L	260 mm	457 mm	254 mm	70 mm

**ENGINEERED FOR HARD WATER**

\*In case of Tank Leakage.

***ELECTRIC  
INSTANTANEOUS  
WATER HEATER***

# Instanio

ELECTRIC INSTANTANEOUS WATER HEATER



CAPACITY : 5 L    COLOR : WHITE

**2** YEAR COMPREHENSIVE WARRANTY

**4** YEAR WARRANTY ON HEATING ELEMENT

**7** YEAR WARRANTY ON INNER CONTAINER



Ferroglass Coated Inner Container



Incoloy Glass Coated Heating Element

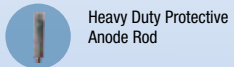

Heavy Duty Protective Anode Rod

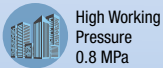

High Working Pressure 0.8 MPa



Bi-Color LED Indicator



Whirlflow technology



Fire Retardant Power Cord



3 Core 3 Pin power cord



IPX4 protection

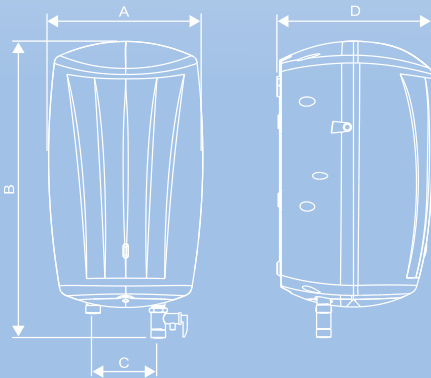

Model	A	B	C	D
INSTANIO 5 L	236 mm	455 mm	100 mm	254 mm



CAPACITY : 5 L    COLOR : WHITE



2 YEAR  
COMPREHENSIVE  
WARRANTY



2 YEAR WARRANTY  
ON HEATING  
ELEMENT



5 YEAR WARRANTY  
ON INNER  
CONTAINER



Heavy duty Heating  
element



SS 304 L Inner  
Tank



Bi-Color LED  
Indicator



Fire Retardant Power  
Cord



High Precision  
Pre calibrated  
thermostat



Rust & shock proof  
outer body



0.65 MPa High  
working pressure

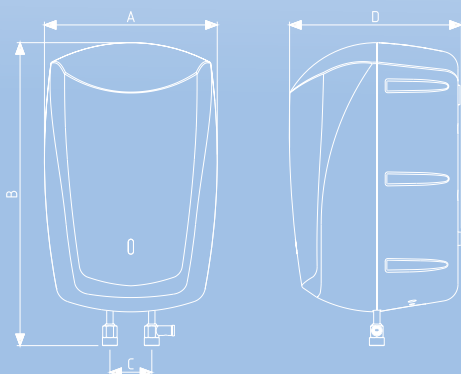

Model	A	B	C	D
CARLO 5 L	260 mm	456 mm	63 mm	258 mm



CAPACITY : 3 L    COLOR : WHITE BLUE



2 YEAR COMPREHENSIVE WARRANTY



3 YEAR WARRANTY ON HEATING ELEMENT



5 YEAR WARRANTY ON INNER CONTAINER



Vitreous enamel coated inner container



Incoloy glass coated heating element



Heavy Duty Protective Anode Rod



High Working Pressure 0.8 MPa



Bi-Color LED Indicator



Fire Retardant Power Cord



3 Core 3 Pin molded plug



High precision pre calibrated thermostat

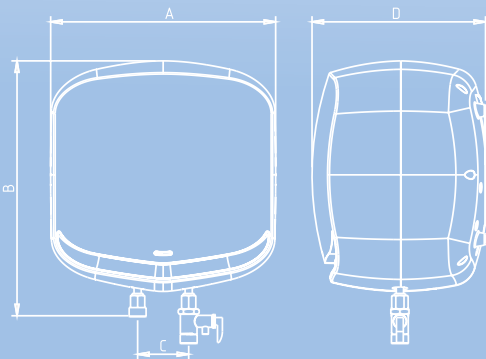

Model	A	B	C	D
BIANCA 3 L	297 mm	336 mm	67 mm	229 mm

# Instanio

## PRIME

ELECTRIC INSTANTANEOUS WATER HEATER



CAPACITY : 3 L    COLOR : WHITE BLUE



2 YEAR  
COMPREHENSIVE  
WARRANTY



3 YEAR WARRANTY  
ON HEATING  
ELEMENT



7 YEAR WARRANTY  
ON INNER  
CONTAINER



Heavy duty  
Heating element



Ferroglass Coated  
Inner Container



Color  
Changing  
LED Indicator



Fire Retardant  
Power Cord



High Precision  
Pre calibrated  
thermostat



Rust & shock  
proof outer body



High Working  
Pressure  
0.8 MPa



Heavy Duty  
Protective  
Anode Rod

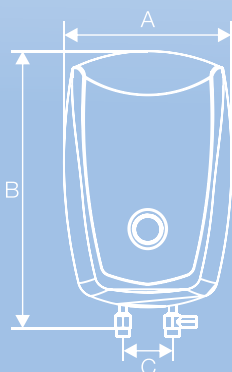

Model	A	B	C	D
INSTANIO PRIME 3 L	214 mm	352 mm	100 mm	219 mm



CAPACITY : 3 L    COLOR : WHITE BROWN



2 YEAR COMPREHENSIVE WARRANTY



2 YEAR WARRANTY ON HEATING ELEMENT



5 YEAR WARRANTY ON INNER CONTAINER



Heavy duty Heating element



SS 304 L Inner Tank



Bi-Color LED Indicator



Fire Retardant Power Cord



High Precision Pre calibrated thermostat



Rust & shock proof outer body



0.65 MPa High working pressure

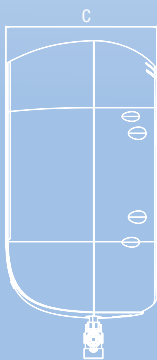
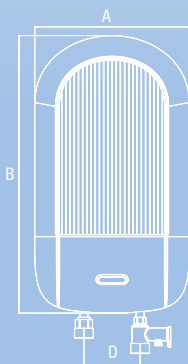

Model	A	B	C	D
ZENO 3 L	184 mm	331 mm	180 mm	67 mm

# Instanio

ELECTRIC INSTANTANEOUS WATER HEATER



CAPACITY : 1 L

COLOR : WHITE BLUE



2 YEAR COMPREHENSIVE WARRANTY



2 YEAR WARRANTY ON HEATING ELEMENT



5 YEAR WARRANTY ON INNER CONTAINER



Heavy duty Heating element



SS 304 L Inner Tank



Color Changing LED Indicator



Fire Retardant Power Cord



High Precision Pre calibrated thermostat



Rust & shock proof outer body



0.65 MPa High working pressure

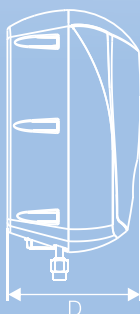
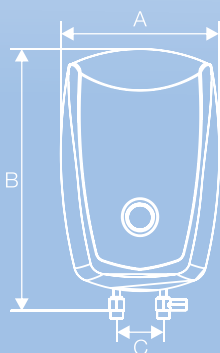

Model	A	B	C	D
Instanio 1 L	205 mm	294 mm	66 mm	184 mm



CAPACITY : 1 L & 3 L    COLOR : WHITE BLUE



2 YEAR COMPREHENSIVE WARRANTY



2 YEAR WARRANTY ON HEATING ELEMENT



5 YEAR WARRANTY ON INNER CONTAINER



Heavy duty Heating element



SS 304 L Inner Tank



Bi-Color LED Indicator



Fire Retardant Power Cord



High Precision Pre calibrated thermostat



Rust & shock proof outer body



0.65 MPa High working pressure

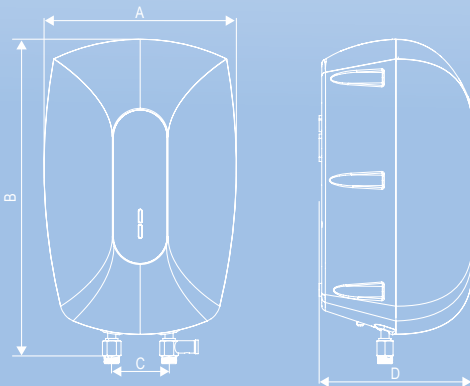

Model	A	B	C	D
RUSH+ 1 L	180 mm	313 mm	66 mm	159 mm
RUSH+ 3 L	225 mm	373 mm	67 mm	180 mm





All dimensions in "mm" provided in charts refers to the corresponding mechanical figures in this document.

Copyright Subsists. Imitation of trade dress, graphics and color scheme of this document is a punishable offence.

E & OE. Pictures and details of the product(s) in this document are merely illustrative. Actual products may vary in colour, design, description and colour combination etc.

All trademarks used herein are property of their respective owners. Any use of third party trademarks is for identification purposes only and does not imply endorsement.



# HAVELLS

ZHGFR00014/SEP/25

\*Conditions Apply

## Havells India Ltd.

Corp Office: QRG Towers, 2D, Sector-126, Expressway,  
Noida-201304 (U. P.) India Ph. +91-120-4771000

Email : [customercare@havells.com](mailto:customercare@havells.com), Website: [www.havells.com](http://www.havells.com)  
Customer Care No. 08045 77 1313 (All Connections),  
011-4166 0303 (Landline)

Join us on Facebook at [www.facebook.com/havells](http://www.facebook.com/havells) and share  
your ways to save the planet !

CIN - L31900DL1983PLC016304