



**HAVELLS**



**ST-Dx**

SMART TECHNOLOGY ADVANTAGE

**BUILDING CRICUIT PROTECTION**  
Catalogue

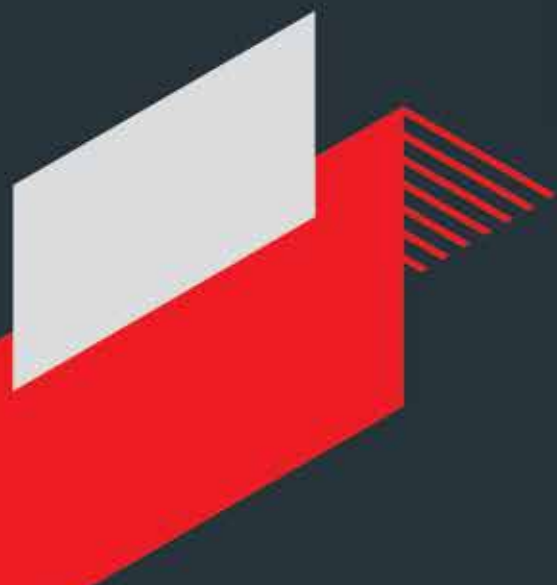

# ABOUT US

## Redefining the modern homes with innovation and excellence

Havells is at the forefront of transforming modern living spaces by offering innovative solutions that elevate everyday experiences. With a deep understanding of consumer needs, the company has expanded its footprint across every aspect of home life, creating environment that are not only functional but also comfortable, stylish, and future-ready. To make these solutions accessible, Havells leverages an extensive distribution network encompassing 18,000 dealers, over 1,000 exclusive brand stores, intensifying presence in modern retail, e-commerce and quick commerce.

The company's portfolio includes power brands like Havells, Havells Crabtree, Lloyd, REO, Havells Studio, and Standard each designed to cater to the unique demands of today's consumers.

Anchored in the 'Make in India' initiative, Havells operates 16 cutting-edge manufacturing facilities across India, producing 90% of its products in-house. At the forefront of Havells product evolution lies its Customer Experience & Designs (CXD) Studio, where creativity and user-centric design converge. This is complemented by its Centre for Research & Innovation (CRI), supported by four advanced R&D centres, enabling Havells to consistently deliver products that are both functional and visually compelling.

Driven by a commitment to innovation, quality, and design, the company also upholds sustainable practices throughout its operations, including eco-friendly manufacturing processes and energy-efficient product design, contributing to a greener and more sustainable future.



CORPORATE OFFICE, NOIDA



State-of-the-Art Manufacturing Unit



Industry 4.0 Process



Center For Research & Innovation



Customer Experience & Design



**16** Manufacturing Units

**~18000** Strong Dealer Network

**4** Research Centres

**48** Offices



# CONTENT



## COMMUNICATION RANGE

## PROTECTION DEVICES



30

Communication Range



40

Arc Fault Detection Device (AFDD)



52

Miniature Circuit Breaker (MCB)  
0.5 A - 63 A



54

Mcb Accessories:  
Aux Contact, VRA, Shunt Trip



58

Miniature Circuit Breaker (MCB)  
80 A - 125 A



60

Residual Current Circuit Breaker  
(RCCB) 16 A - 100 A



64

Residual Current Circuit Breaker  
With Overload & Short Circuit  
Protection (RCBO)

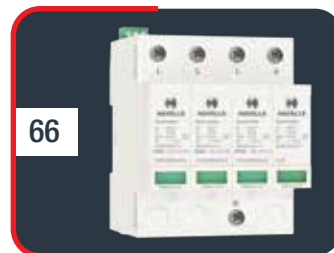

66

Surge Protection Devices (SPD)

## CONTROL DEVICES & MONITORING



68

Time switch

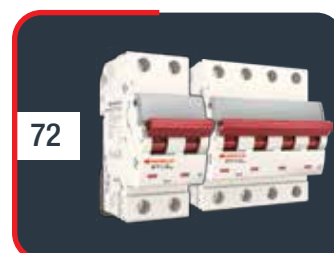

72

Isolator



74

ACCL



78

Modular Contactor

## DISTRIBUTION BOARDS



82

IP43 Distribution Board  
SPN & TPN



84

Communication  
Distribution Board

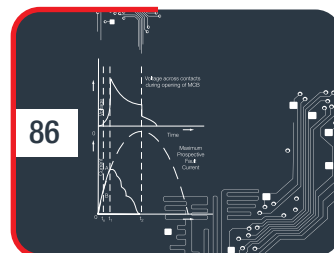

86

Product Technical Data

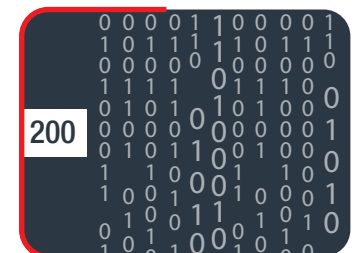

200

Product Codes

# HAVELLS STADx RANGE FOR NEW AGE SMART BUILDINGS



EFFICIENT

FAST TRIPPING





ADVANCED  
PROTECTION  
LEVEL

ROBUST

ANALYSIS  
FRIENDLY





COMMUNICATION  
READY

# COMMUNICATION ENABLED MULTIPLE FUNCTIONALITIES FOR NEW AGE SMART BUILDINGS

## Comprehensive Range coupled with functionalities & aesthetics

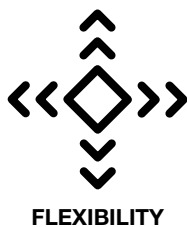
Communication Ready devices  
MCBs from 0.5 A to 125 A with 10 kA breaking capacity  
RCDs upto 100 A with 30 mA to 300 mA  
Control and indication devices



 **Add on devices for greater flexibility**  
Always upgradable & expandable

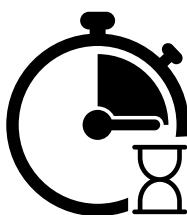

 **Quick installation and easy operation**  
optimum space utilization





Circuit labeling for convenient trouble shooting  
 factory fit status indicator and inscription window



Complete range conforms To latest IEC standards



## POWER MANAGEMENT

### STEPPING

towards energy efficiency.



### Schedule

Set, automate and control operations of load to optimize energy consumption.



### Configure

Configuring all devices, locally and remotely.





### Supervise

Real time monitoring & remote controlling actions, i.e. remote switching ON/OFF from the software.

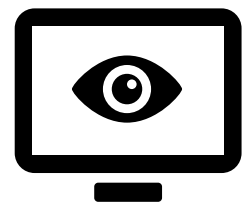

### Register

Register the consumption of all the users of the installation.

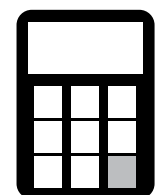

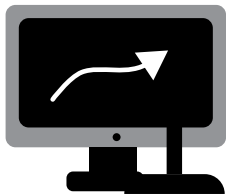

### Measure

Continuous monitoring of electrical power consumption by software.



### Record

Electrical system data is stored automatically in secure and reliable space.



### Easy maintenance

Reduce on-site visits & maintenance costs.





**Control**

Automatic Programmed Controlling actions to Switchgear devices, i.e. recloser.

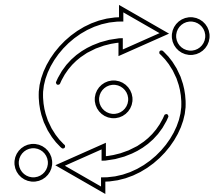

**Data analysis**

Easy analysis & instant creation of data representation charts in attractive graphic pages, data log reports etc.

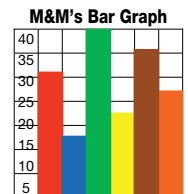

## READILY CONNECTABLE, FLEXIBLE, RELIABLE, AND EXTENDABLE

Unlike conventional distribution panels that require extensive wiring, STADx Bridge can be easily integrated into any existing facility management system. Its flexibility adds reliability, extendibility, and upgradeability to your customers. With robust RS485 communication and wireless communication, the STADx Bridge communication system can adapt to any future developments, and becomes a key element in your energy efficiency strategies.

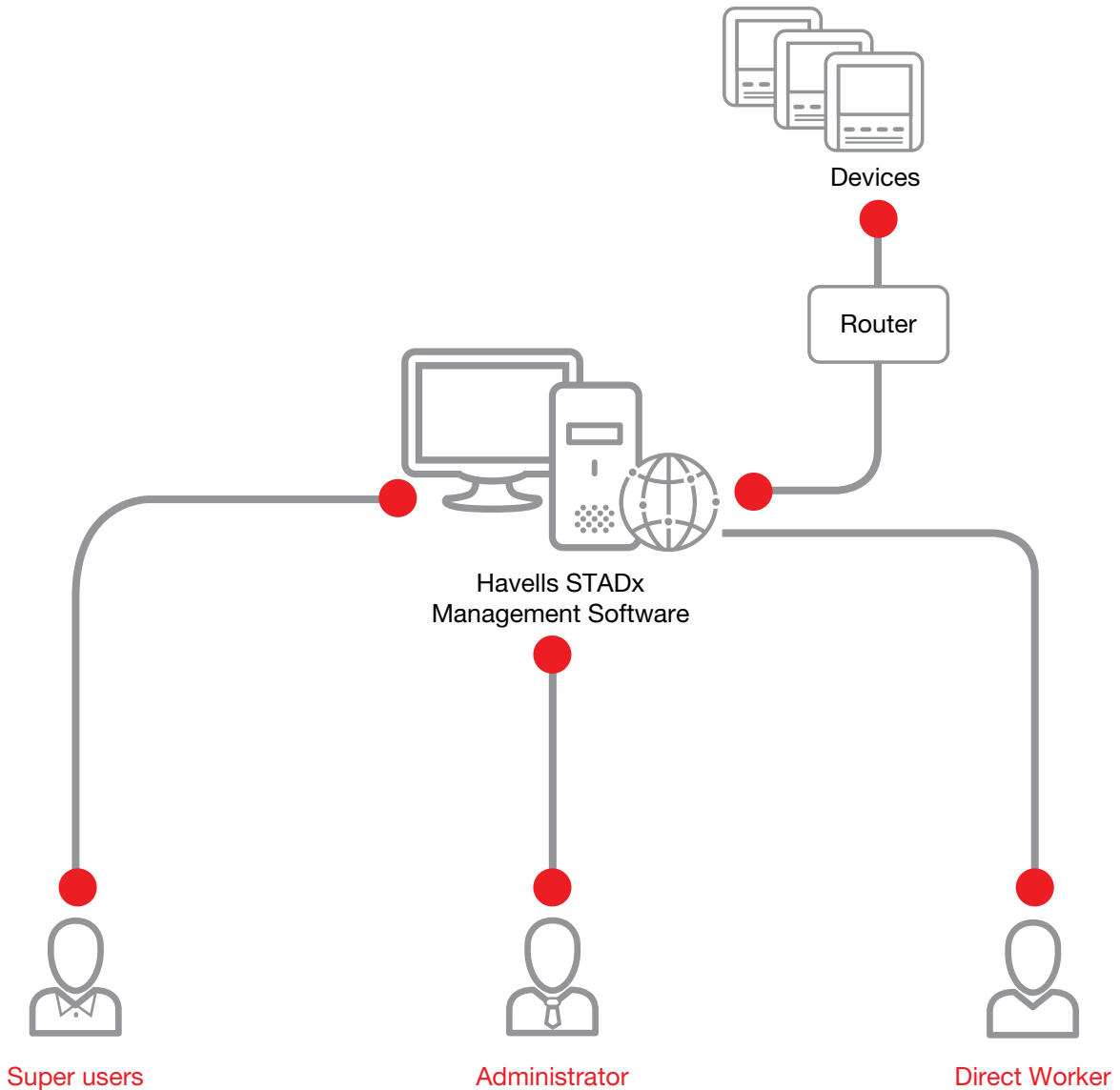

- Viewing of field devices status defined by administrator
- Creation/modification of graphic pages and reports

- Control & monitoring of devices
- Gets fault alerts
- Schedules maintenance work

- Viewing of field devices status defined by administrator
- Gets fault alerts
- Performs maintenance work



simple to choose...

Communication



Monitoring

Controlling

Metering



simple to configure...

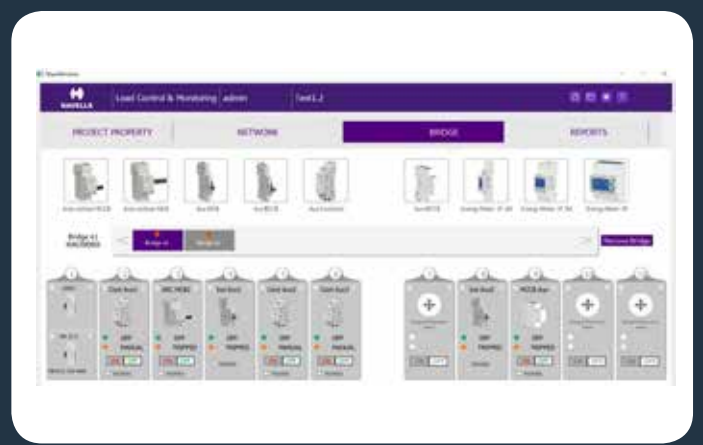

Simple to control and monitor...

## POWER MANAGEMENT

The aim is to provide users with an easy to use and understand solution for controlling and monitoring the building's equipment such as lighting, power and ventilation.

STADx Bridge provides a much cheaper and easy to maintain solution which works as a smart STADx Bridge between BMS Automation interface and existing devices. Thus leading to huge energy savings and automation in dirt cheap price.

---

***Track Your Electric Consumption Before Controlling The Devices.  
The More You'll Track, The More You'll Save.***

### The Problem

- Difficult to manage several MCB/devices installed across buildings
- Prone to Human Made Mistakes
- No real time device/MCB status
- Longer breakage time in electric supply due to manual MCB management
- Limitations of service and support during nights, or due to rain or health issues



---

### The Solution

- Smart & Next-Gen Single Point Power Control System
- Real Time Device Status
- IoT based solution
- Smart Protection
- Action Prediction Based On Devices' events
- Single Click switch-off or switch-on any device from remote/control room
- Optimal Resource Utilization





# OPTIMIZING ENERGY CONSUMPTION

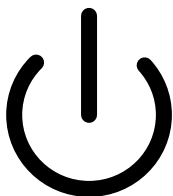

Programmable ON/OFF schedule in advance.



Prevent local ON/OFF (e.g. light load during day) for energy saving and secure operations.



Less Manual intervention to the circuit board.





Senses both Permanent and transient faults. Reports and takes necessary actions accordingly. Decreases down time or power loss in case of transient faults.

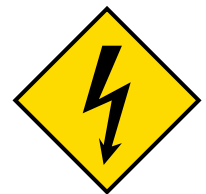

Increase continuity of service.



Automate, Schedule and control operations of load to optimize energy consumption.



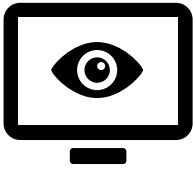

Real time monitoring & recording of complete history of devices: off-time, running time, down time, number of switching operations, details of faults etc.

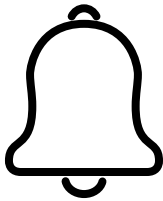

Immediate alarm in case of fault tripping through software, sms or e-mail alerts.



Software and system integration increases the reliability and accessibility to the device.



Perform safe and secure operations as well as data preservation.

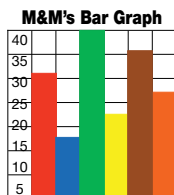

Proper data collection and analysis of energy consumption can increase energy efficiency.



## WIRELESS/WIRED NETWORK CONFIGURATION

- Single Interface to manage wire & wireless connected devices
- Easy DIY configuration for desired network changes

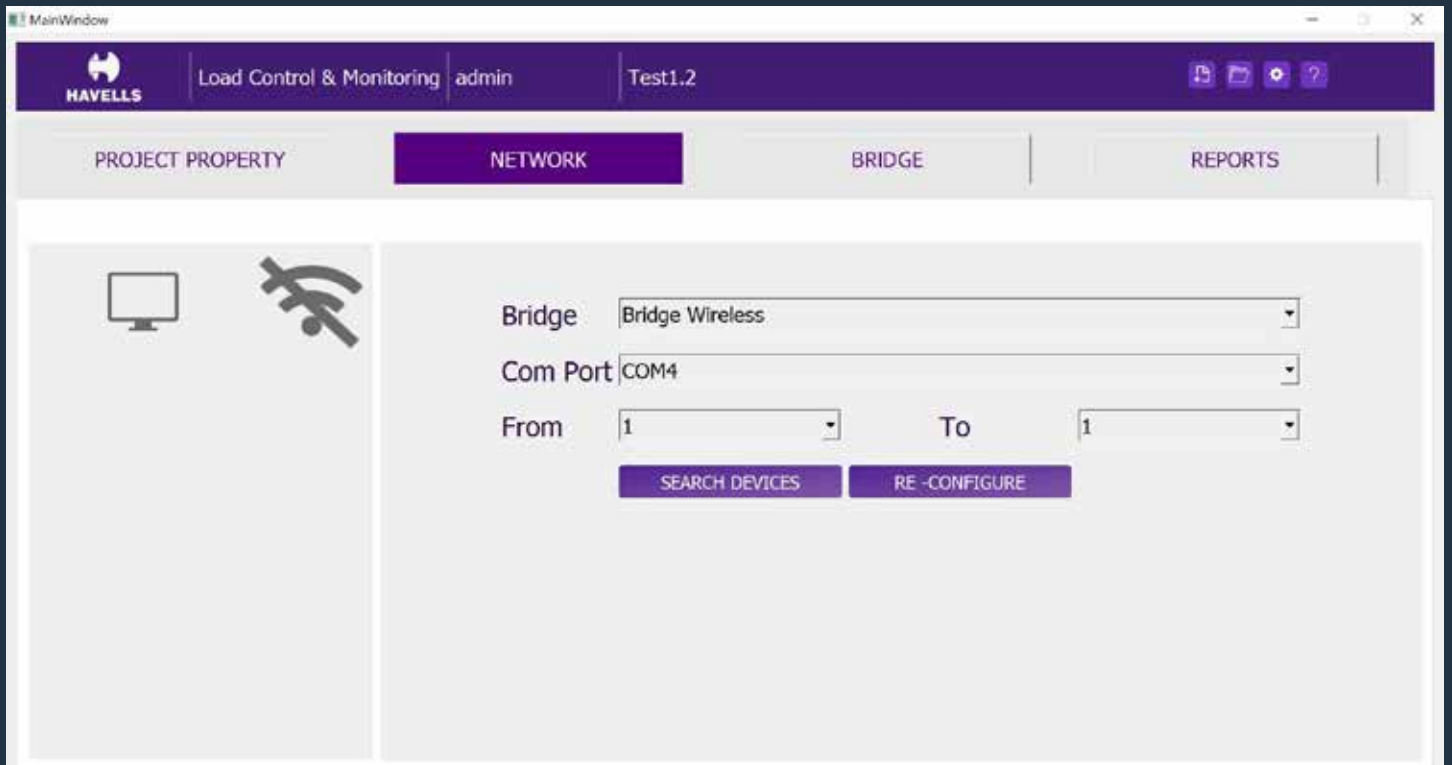

# REAL-TIME DEVICE DASHBOARD

- STADx Bridge list and Channel View
- Real Time Device Power On/Off status
- Real Time Power Trip Alert/Failure Alert
- Drag and Drop Device Configuration
- Meter Reading
- Energy Consumption Alerts
- Monitor STADx Bridge connection status
- Load Scheduling for automated controls.
- Event generated notifications for each device.

The screenshot displays the HAVELLS Load Control & Monitoring interface. At the top, the HAVELLS logo is on the left, and the text 'Load Control & Monitoring admin Test1.2' is on the right. Below this is a navigation bar with 'PROJECT PROPERTY' and 'NETWORK' tabs. The main area shows five device categories: Auto recloser RCCB, Auto recloser MCB, Aux MCB, Aux RCCB, and Aux Contactor. A bridge selection bar shows 'Bridge 41 WAC000001' selected over 'Bridge 42'. Below this, six device cards are shown, each with a status indicator and control buttons:

Device ID	Label	Status	Control Buttons	Tested	
1	LABEL	EM IP 2	587211.534 kWh		
2	Cont Aux1	OFF	ON OFF	<input type="checkbox"/>	
3	ARC MCB1	OFF TRIPPED	ON OFF	<input type="checkbox"/>	
4	Ind Aux1	OFF TRIPPED	TESTED	<input type="checkbox"/>	
5	Cont Aux2	OFF	ON OFF	<input type="checkbox"/>	
6	Cont Aux3	OFF	ON OFF	<input type="checkbox"/>	



## EASY CONFIGURATION

- Drag and Drop Device respective Channel Number
- Device status (On/Off/Trip/Healthy/Auto/Manual)
- On and Off Control Buttons for remote command
- Lock/Unlock Device
- Priority Scan for the Open STADx Bridge for faster updates
- Meter Setup Options

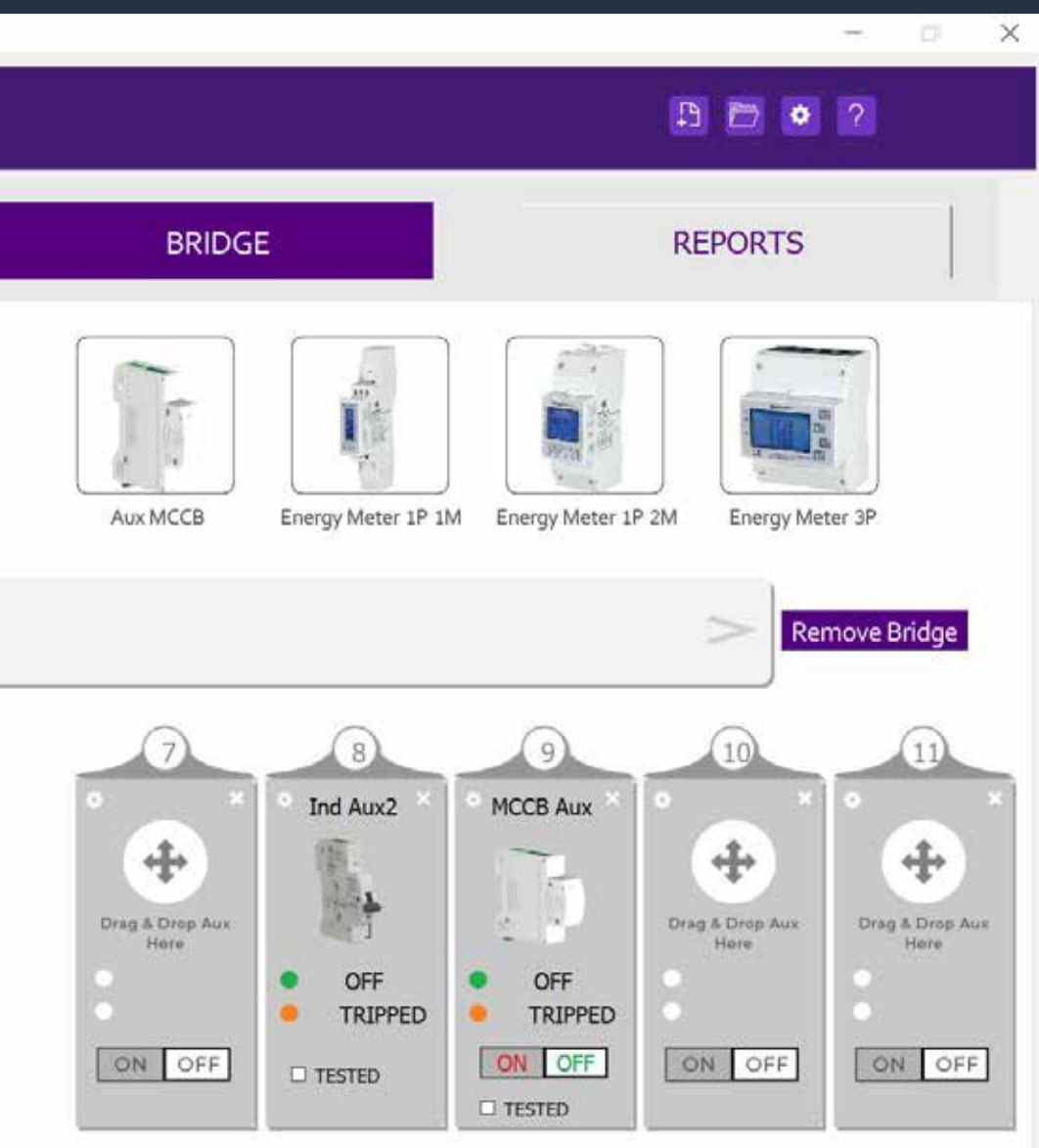

# MAKING SWITCHGEAR DEVICES SMARTER, SAFER, EASILY MANAGEABLE AND THUS ENERGY EFFICIENT.



Energy quality analysis



Report of trip history



Report of ON/OFF history

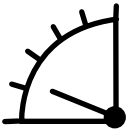

Consultation of instantaneous values

## Analysis Friendly

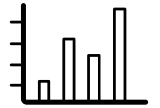

Trend charts



Creation of custom graphic pages



Customised energy consumption reports



Data logs



## A Fully EMC-certified communication system

Trust your installation status

With the STADx Bridge communication system, special attention was given to electromagnetic compatibility (EMC). Most trust worthy connections and integration of data, and study precisely what is happening on circuits at all times.

## 100% reliability

Guarantee data integrity for the life of your installation

The STADx Bridge devices are fully tested and compliant with industry regulations. The STADx Bridge communication system is based on reliable 24 V dc low-level contacts that guarantees efficient data transmission over time.



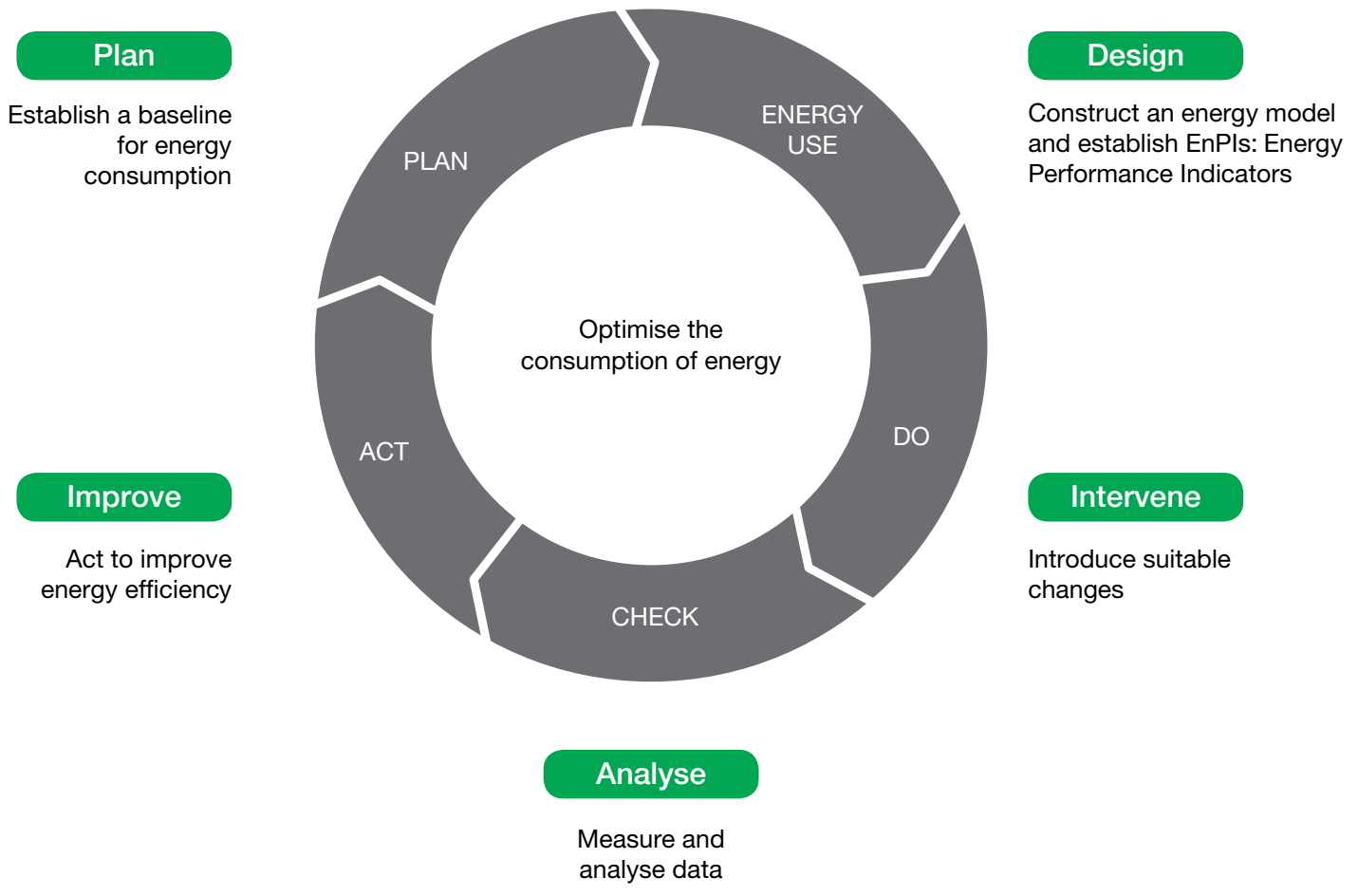

### Absolute Safe

The STADx Bridge communication system guarantees safe, reliable operation for the lifetime of your installation. It is specifically designed to integrate safely into final distribution panels, and gives your customers satisfaction to the greatest level of protection and control, even in demanding environments.



EMC tested for immunity, radiated and conducted safety



#### Fully compliant

IEC 61132-2, IEC 63024, IEC 60947-5-1, IEC 60947-5-4



The communication ready system is high quality without compromise

# SOLUTION POWER FROM PLANT TO PLUG

## Full Range of mounting & wiring accessories with Communication architecture

### Devices:

- Complete din-rail mountable devices, STADx Energy Meters, auxiliaries
- Integration of MCCBs
- Wiring accessories
- User-interface

Open/Close status  
Tripped status  
Number of openings  
Number of trippings

Open/close status  
Number of switchings  
Load running hours

### Bridge

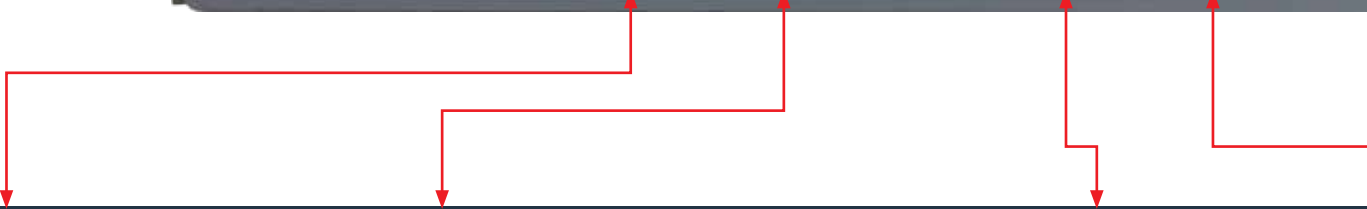

### Monitoring



### Aux Devices for MCB & RCCB

- Indication (ON/OFF/TRIP)

### Auto recloser for MCB & RCCB

- Indication (ON/OFF/TRIP)
- Automatic as well as Remote switching



**Working:**

- Local & Remote Status Monitoring of circuit-breakers
- Remote load control via contactors

**Communication System:**

- Wired (RS-485)
- Wireless (RF-Based)



Energy utilization  
Power consumption



**Controlling**

**Metering**



**Aux Devices for Contactors**

- Indication (ON/OFF/TRIP)
- Remote switching

**STADx Energy Meters**

- Single Phase
- Three Phase

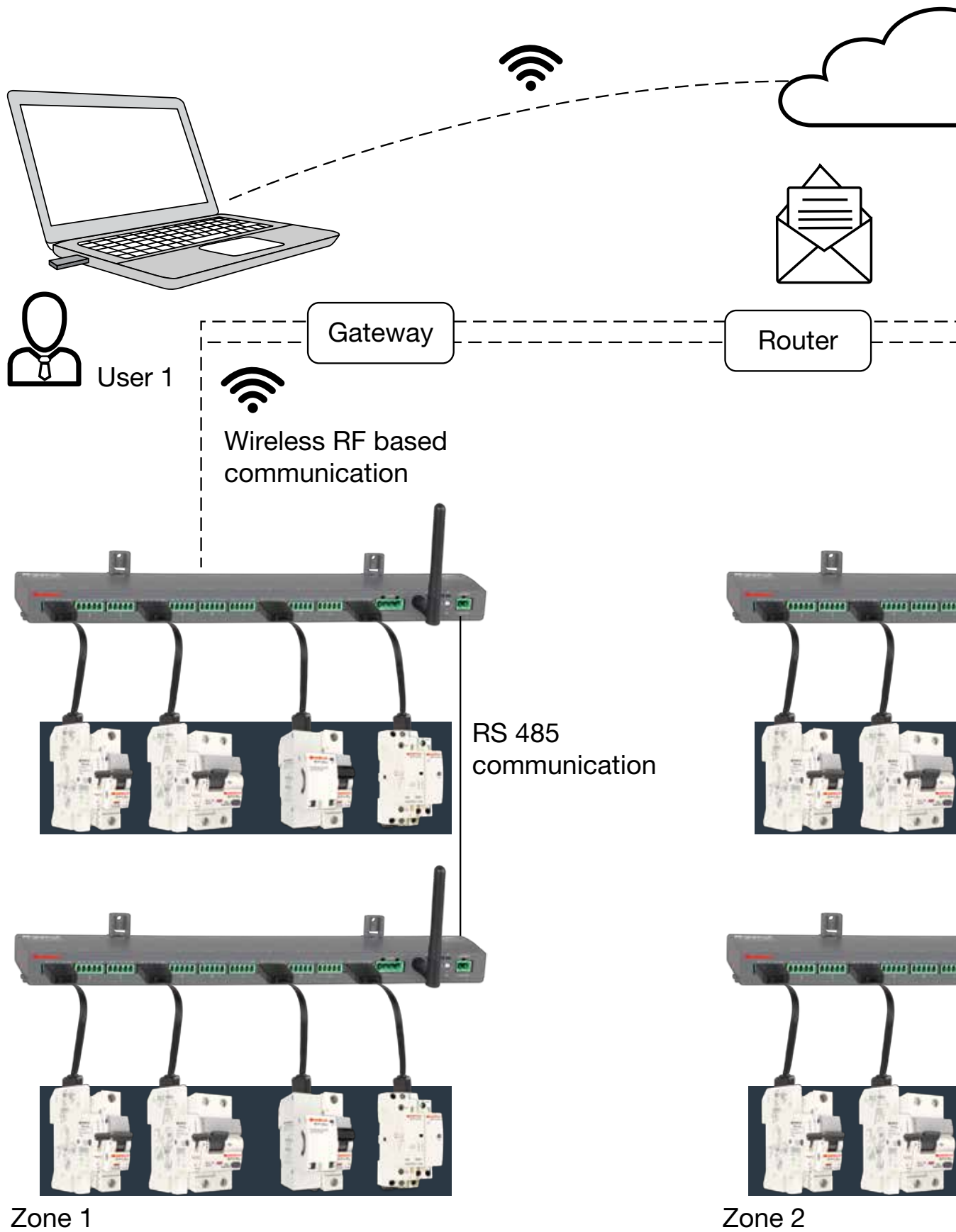

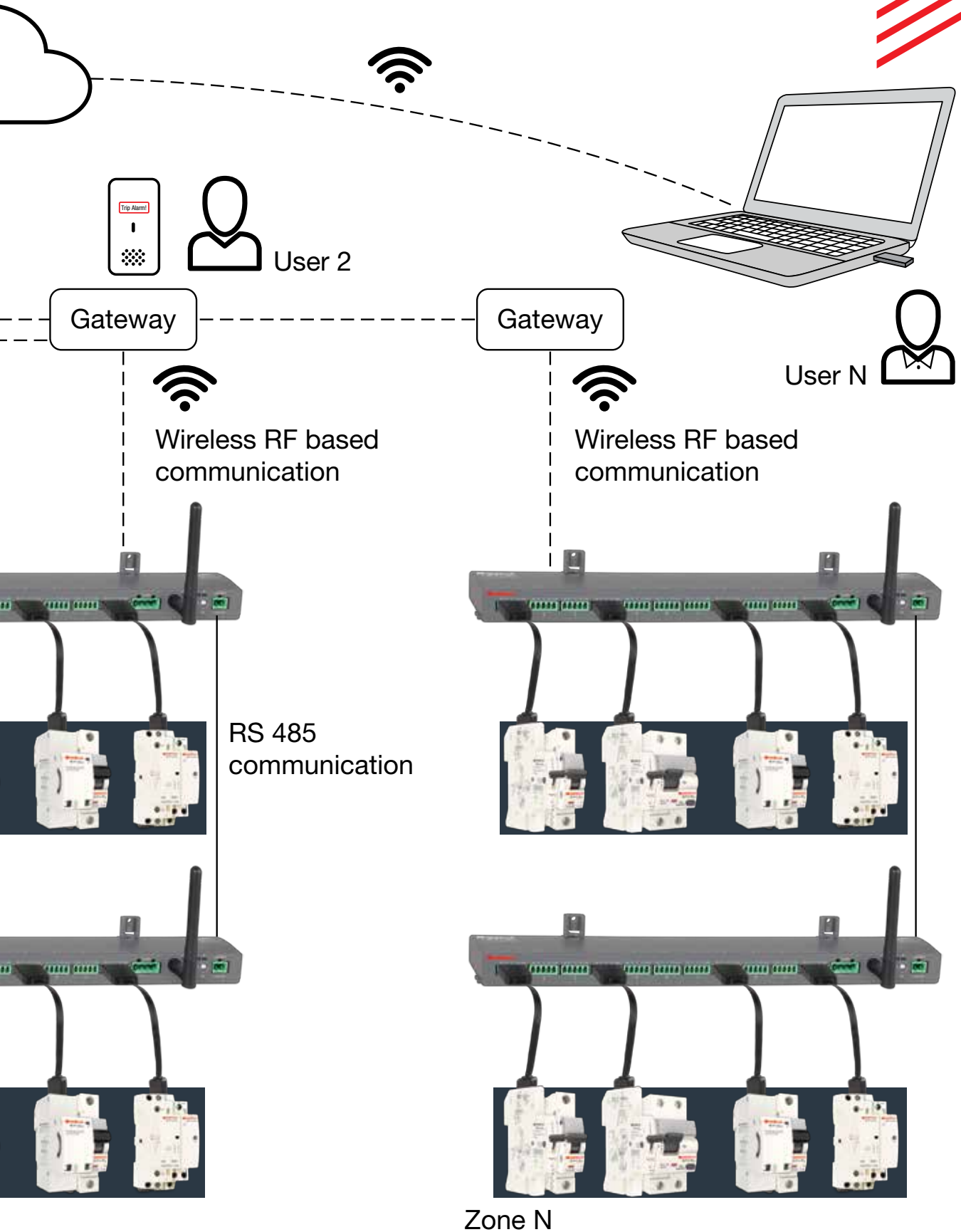

Zone N

# STADx BRIDGE

The STADx Bridge communication system is used to connect final distribution boards to any supervision system. Modular equipment in the STADx Bridge communication system is used to monitor, measure and control electrical distribution boards via a Modbus & RF communication network. The STADx Bridge communication system concentrates the data from electrical distribution boards in real time, thus contributing to achieving energy efficiency targets. STADx Bridge is of 2 Variant:

- STADx Bridge Wired
- STADx Bridge Wireless

Devices which can be connected to the STADx Bridge device include:

- Aux Contactor
- Aux MCB,
- Aux RCCB,
- Aux MCCB,
- Auto Recloser MCB,
- Auto Recloser RCCB,
- Energy Meter

STADx Bridge Wireless



DHBWIPAV

STADx Bridge Wired



DHBRIPAV



The STADx Bridge device is an intermediary between the supervisor and various electrical appliances. It can therefore be used to retrieve and process data received from devices and also control them. The functions available depend on the type of connected devices. It can connect upto 11 communication ready devices and 2 STADx Energy Meters can be connected to each channel.

**Features:**

- Remote control of communication ready devices
- Real time monitoring and analysis of data from STADx Energy Meters
- Status and alarms from circuit breakers
- Automatic reports can be scheduled at custom intervals
- Increase continuity of service
- upgrading existing installations with ready-to-connect communication devices.
- DIN rail mounting

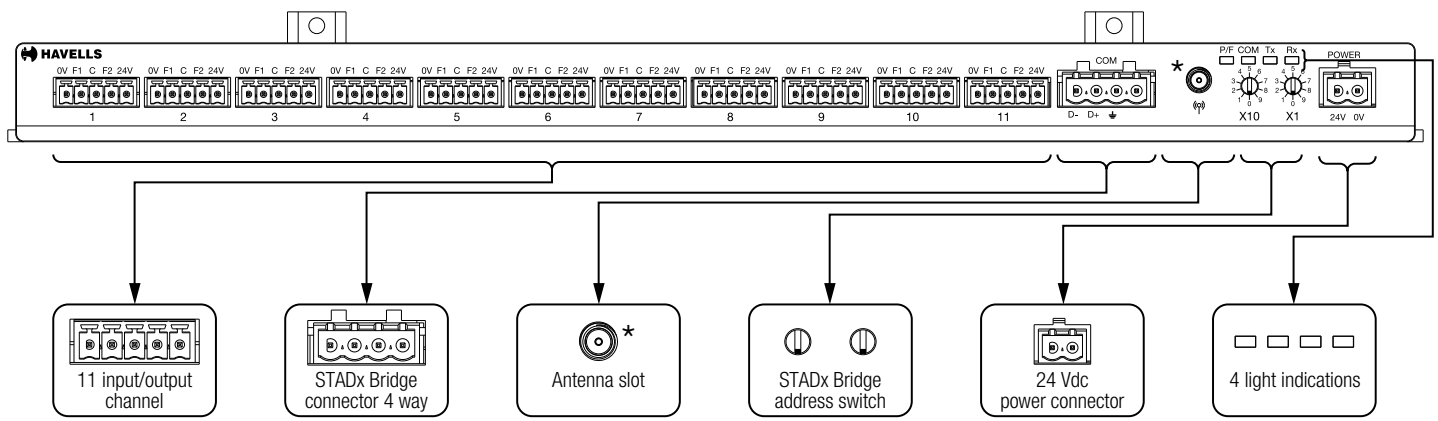

\* Antenna slot present only in wireless STADx Bidge

## AUX MCB & RCCB

Aux MCB & RCCB is a modular device which can be used as an add-on with Havells STADx range MCB/RCCB for remotely monitoring their status (ON/ Manual OFF/ TRIPPED). It is useful in new age building management systems where real time tracking of switchgear status will help in taking prompt corrective actions, record device event logs and allowing proactive maintenance.

This auxiliary is designed for use with STADx Bridge, with which it can connect easily via pre-fabricated wiring accessories having connectors at both end of pitch 3.81 mm. Signaling is done by means of 24 V dc feedback.

### Features:

- Remote indication of the state of circuit breaker
- Circuit-breaker resetting after tripping reducing downtime

### Product Fitment

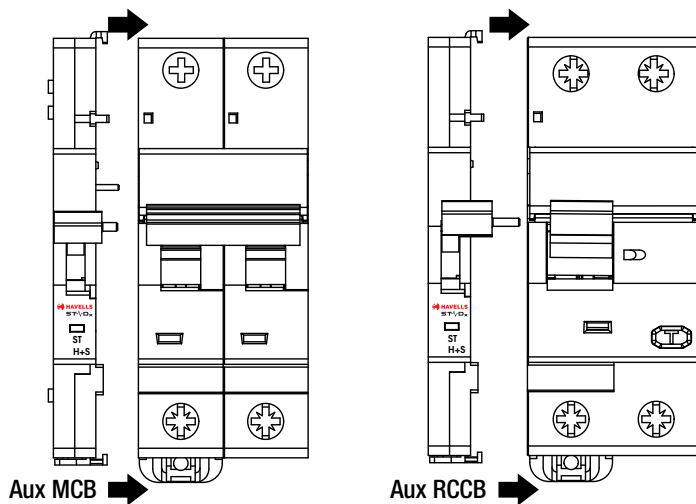

Aux MCB



Aux RCCB



## AUX CONTACTOR

Auxiliary contactor is a modular device which can be used as an add-on with modular contactors for remotely controlling and monitoring their status. It is useful in new age building management systems where remote load switching is an important requirement.

This auxiliary is designed for use with STADx Bridge, with which it can connect easily via pre-fabricated wiring accessories having connectors at both end of pitch 3.81 mm. When used with CommX Bridge, the control and signaling is done via 24 V dc digital inputs and outputs (centralized control).

Alternately, local controlling of contactor via 230 V ac supply is also possible.

### Features:

- Remote control of the contactor

### Product Fitment

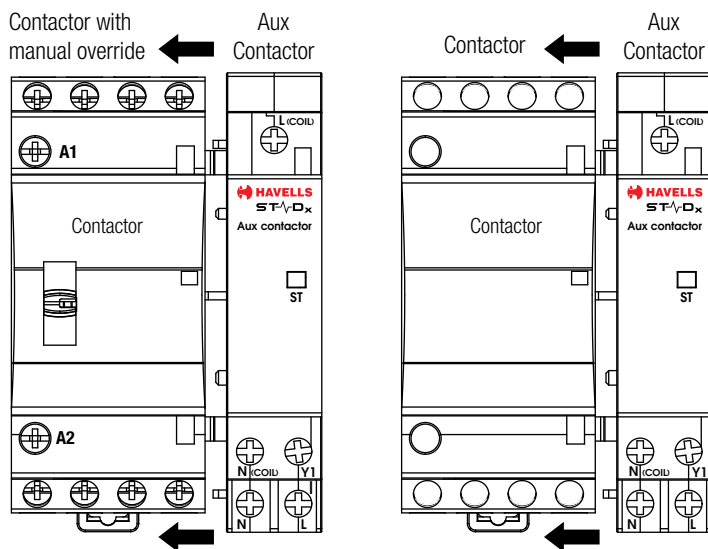

## RECLOSER MCB & RCCB

Recloser MCB & RCCB is an electromechanical device, to be used for controlling the MCBs, and RCCBs of Havells Switchgear range. The device is motor operated, and hence rotates the knob which moves the switchgear knob up or down as per command.

### Features:

- Automatic reclosing of the circuit breaker after tripping
- Increase the availability of installations without supervision, isolated, hard of access and demanding very great availability by restoring them to operation without intervention by personnel in the event of a transient fault (disturbances, overvoltage condition, etc.).
- For example: mobile telephony systems, motorways, pumping stations, service stations, ATMs, public lighting, tunnels, etc.
- Status indication through LEDs
- Auto/manual mode selection feature.
- Padlock to provide mechanical locking.
- DIN Rail mounting.

### Product Fitment:

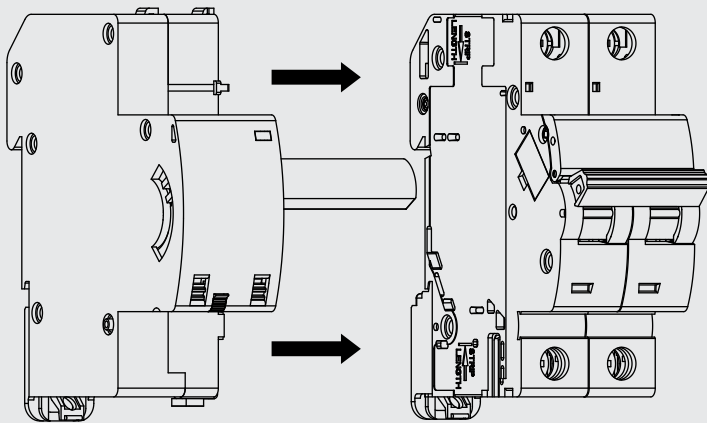

Recloser MCB

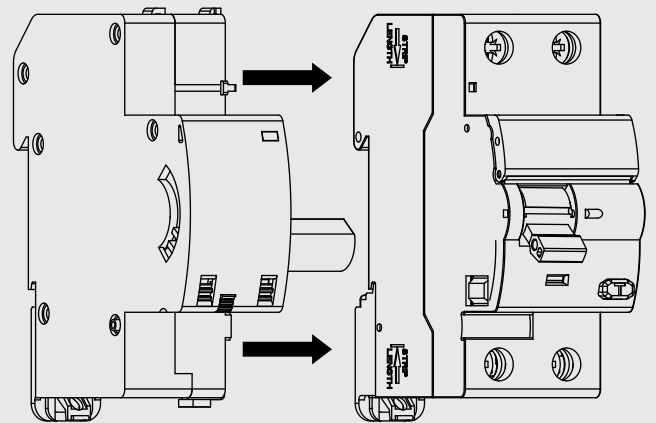

Recloser RCCB



## AUX MCCB

Aux MCCB is designed as a unique product to monitor and control the state of MCCB (ON/ Manual OFF/ TRIPPED). This auxiliary is designed for use with STADx Bridge, with which it can connect easily via pre-fabricated wiring accessories having connectors at both end of pitch 3.81 mm. When used with STADx Bridge, the control and signaling is done via 24 V dc digital inputs and outputs (centralized control).

### Features:

- Remote monitoring and controlling the state of MCCB.
- Status indications through LEDs.
- DIN rail mountable.
- Universally compatible with MCCBs.



## STADx DONGLE

STADx Dongle acts as a communication system between the STADx Bridge and the PC which can be implemented both in wired and wireless manner. It either converts serial signals from USB into RS485 signals or converts serial signals from USB into RF signals. It acts as a link between the PC and STADx Bridge with the help of wired RS485 connection or through wireless medium.

The STADx Dongle comes in three variants:

- STADx Dongle Wired
- STADx Dongle Wireless
- STADx Extend
- STADx Transmuter

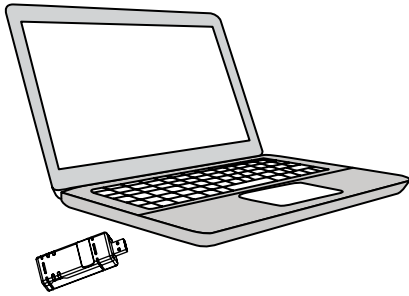

## STADx ENERGY METERS

STADx Energy Meters can be integrated in an electrical installation to measure energy consumed by a single phase or three phase circuit. These meters are mounted on a DIN rail and are suitable for installation in distribution boards and enclosures. It offers significant benefits to the user putting measurement at the heart of energy efficiency. Energy consumption can be monitored within a building to provide information about where the electrical energy is being consumed. This helps customers to save energy and increase safety.

Using STADx communication range the meter can monitor and communicate the electrical parameters being measured. It is a cost attractive, feature rich metering offer for din rail enclosures.

Havells offers STADx Energy Meters in three variants:

- Energy meter 1P 1M
- Energy meter 1P 2M
- Energy meter 3P

### Features:

- Multifunction metering units.
- Compatible with STADx Bridge devices.
- Interactive LCD display with backlight
- Measure, monitor and communicate essential electrical parameters.
- Easy to choose, install and use
- RS485 Modbus communication interface.
- Data transmission via pulses
- Accuracy class 1
- No external CT required
- DIN rail mounting



## ACCESSORIES

Pre-wired connector to connect STADx Bridge with communication ready auxiliary devices

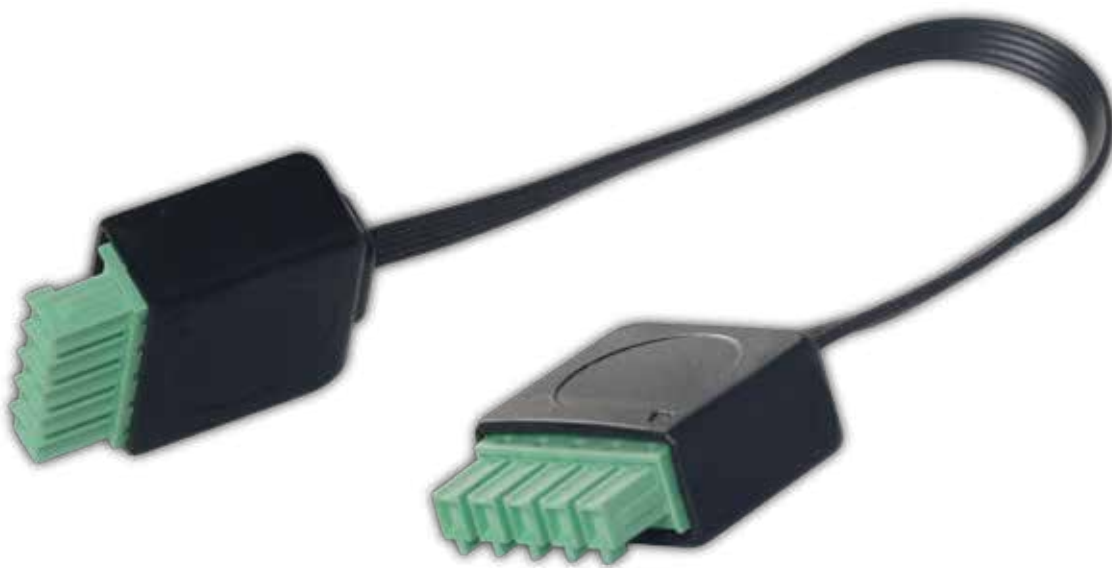

## STAD<sub>x</sub> BAR

### Features:

- Easy to add new switchgear devices
- Saves from complex wiring
- Fast connection with spring terminal





# AFDD

## ARC FAULT DETECTION DEVICE

### Variant

AFDD  
AFDD with RCBO

### Range

16 A, 32 A & 40 A

### Execution

SPN

### Specification

IS/IEC 62606 & IEC 60898-1

IEC 61009-1



IEC 62606  
IEC 60898-1



COMMUNICATION  
READY

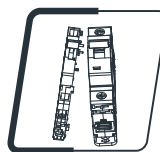

ADD ON  
AUXILIARY



100%  
Recyclable





**Inscription Window**  
Ensures circuit identification and hence reduces maintenance downtime

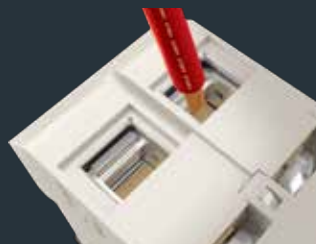

**Large Cable Terminals**  
The terminals are Suitable for cables upto 35 mm<sup>2</sup> cross section area. Thus making it suitable for copper and aluminium cables



**Safety Terminals**  
They guide the cable towards the cage terminal and avoid improper cable termination



**Bi Stable Clip**  
Every device is provided with a dual position DIN rail clip, so it becomes much easier to change a device from a device bank connected to a bus-bar, without disturbing the existing wiring



**Dual Termination**  
Two types of busbar can be used, that is, Fork Type and Pin Type



**Test Button**  
Test button for regular inspection/testing

## ARC FAULT DETECTION DEVICE

A complete range of devices, that offer protection over and above the required standards including prevention against electrically ignited fire caused by series and parallel arc.

### Technical Specification

Standard Compliance	IEC 62606 & IEC 60898-1
No of Poles	1P+N
Rated Current In (A)	16 A, 32 A & 40 A
Rated Voltage (Un)	240 V ac
Instantaneous Tripping Current	"C" Curve
Rated Short Circuit Capacity (Icn)	10 kA

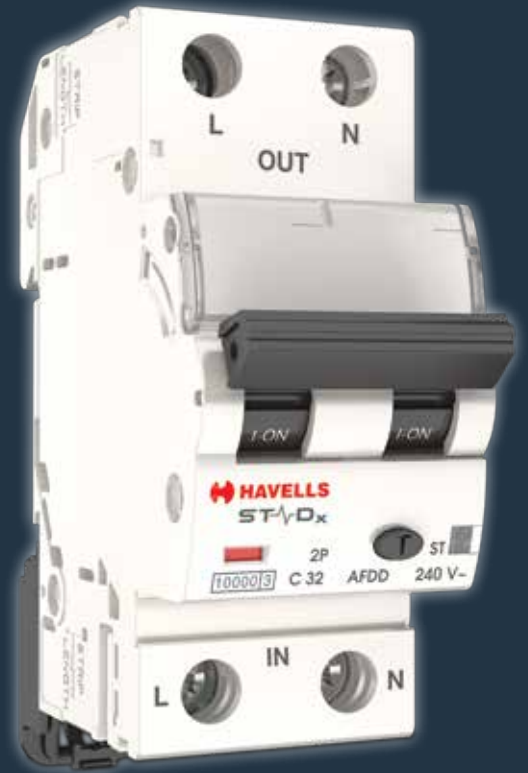

## AFDD with RCBO

A complete product that offer protection against arc faults, leakage current, over load & short circuit along with over voltage, in a single device.

Technical Specification	
Standard Compliance	IEC 62606 & IEC 61009-1
No of Poles	1P+N
Rated Current In (A)	16 A, 32 A & 40 A
Rated Voltage (Un)	240 V ac
Rated Residual Operating Current (I $\Delta$ n)	30 mA, 100 mA
Instantaneous Tripping Current	"C" Curve
Operating Characteristics in Case of Residual Currents	A type
Rated Short Circuit Capacity (Icn)	10 kA



## FEATURES



Provides protection against arc faults, short circuits Overloads, and Leakage.

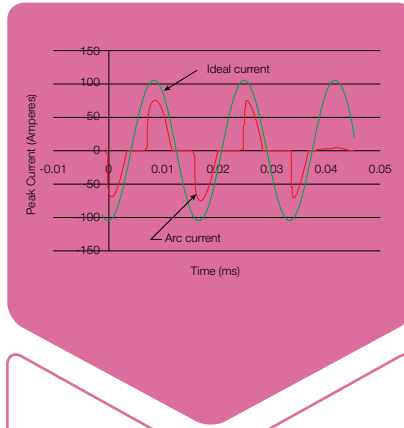

Resistant to nuisance tripping i.e. it distinguishes between normal arcs that can appear at the time of switching and abnormal arcs that could lead to potential risk of fire.

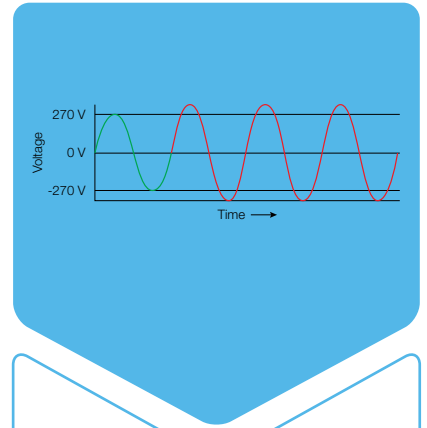

It offers protection against overvoltage higher than  $270\text{ V} \pm 5\%$ , thus prevents any damage to electrical appliances.



Contact position indicator is provided in Combined 1P+N MCB AFDD for fast and easy identification of contact status. Green: contacts opened Red: contacts closed



Test button is provided for internal self-testing to check the working conditions of AFDD.



It has provision of inscription window.





## Electrical Fire, A Constant Danger

It is well known that electrical fires do exist and take many lives and damage significant amounts of property. Even a minor electrical fault can have serious consequences. That's why the electrical installation in every building must be protected against fires caused by electricity. Havells introduces new range of protection devices giving comprehensive protection against fires caused by electricity for humans, systems and property. It will distinguish between operational interference and hazardous arcing faults and will fill the functional gap of the existing protection devices-circuit breakers, residual current circuit breakers and fuses –and will move the safety to a higher level.

The objective is to protect electrical circuits in a manner that will reduce the risk of it being a source of an electrical fire. So in order to successfully detect series and parallel arc faults we need an Arc fault detection device.

They cannot be replaced by any other protective device like miniature circuit breakers (MCBs), surge protection devices (SPDs), or residual current devices (RCDs). While these protect against specific electrical hazards, they are not designed to detect arc faults.

## What Do You Need To Know About Electrical Fires?

**Electrical fires can be a silent killer occurring in areas of the home that are hidden from view and early detection. At 230 V and 2.5 A it only takes 1 second for a damaged electrical insulation to catch a fire.**

Every 24 seconds, a fire department in the United States responds to a fire somewhere in the nation.

According to a 2017 National Fire Protection Association report, between 2010 and 2014, U.S. municipal fire departments responded to an estimated annual average of 45,210 home structure fires involving electrical failure or malfunction. These fires caused annual averages of 420 civilian deaths, 1,370 civilian injuries, and \$1.4 billion in direct property damage.

As per the NFPA, wiring and related equipment accounted for the great majority of home fires and losses involving electrical distribution and lighting equipment (69% of fires, 56% of civilian deaths, 53% of civilian injuries, and 66% of direct property damage). Cords and plugs accounted for 10% of fires, but 28% of civilian deaths and 20% of civilian injuries, as well as 12% of direct property damage.

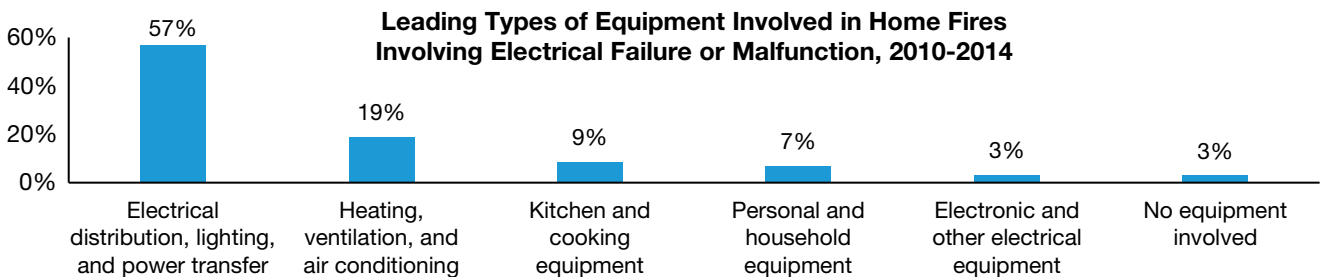

## Electrical Malfunctions

Electrical fires can be caused by a number of malfunctions:

- **Arc faults**-Damaging of a wire/cord can create a hot spot which results in carbon deposits with increasing temperature. With time this can eventually lead to fire by subsequent arc faults. AFDD provides protection against such faults.
- **Short circuits**- This occurs when two conductors come into contact leading to increasing electrical current within a very short duration of time and destroying electrical wiring. This may then ignite any nearby combustible material. MCB and RCBO provide protection against such faults.
- **Overloads**-This occurs when an electrical installation carries more current than the rated current it is designed for. The wire gets overheated and can catch any materials in the vicinity on fire. MCB and RCBO provide protection against such faults.



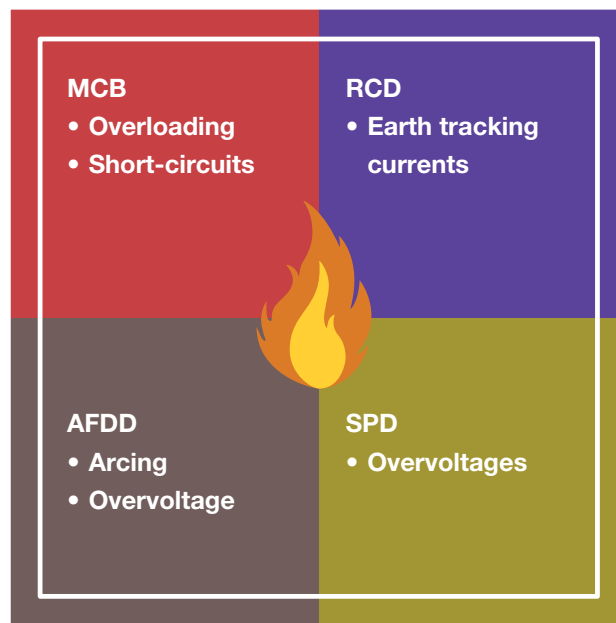

- **Earth Leakage Currents**-This mainly occurs due to damaging of electrical insulation or presence of moisture. The electrical current flows toward the earth or nearby conducting materials. Earth leakage current can cause fires and if it comes in human contact it can lead to electrocution. RCCB and RCBO provide protection against such faults.
- **Lightning Strikes**- Surges can lead to extremely high voltages which leads to instant deterioration of electrical loads and can immediately catch fire. SPD provides protection against such faults.
- **Over Voltages**-This occurs when a load operates at higher voltage for a long duration leading to its components getting overheated and can potentially start a fire.



## Enhanced Protection Against Risk of Fire

Electrical distribution needs are continuously evolving in residential, commercial and industrial sectors. Improved operational safety, continuity of service, greater convenience and operating cost have assumed a tremendous significance. Our aim has been to design products to continuously adapt to these changing needs.

The existing protection scheme involves:

- Basic Insulation: Insulation of live parts (Class II equipment, cable insulation, barriers or enclosures)
- Fault Protection: Automatic disconnection of the power and the fault
- Additional Protection: For example, RCD not exceeding 30 mA

Arcing creates high intensity heating at the point of the arc resulting in burning particles that may over time ignite any material in its vicinity.



Residual current devices (RCDs) are efficient to reduce the risk of fire by detection of leakage current and arcing to ground as a consequence of tracking currents within an electrical installation. But RCDs are not able to reduce the risk of electrical fire due to series or parallel arcing between live conductors.

AFDDs are designed to detect low level hazardous arcing faults that circuit breakers, fuses and RCDs are not designed to detect.

Smoke alarms are designed to alert occupants and fire extinguishers to take action when a fire occurs whereas AFDDs are designed to detect electrical arc faults to prevent a fire from starting.

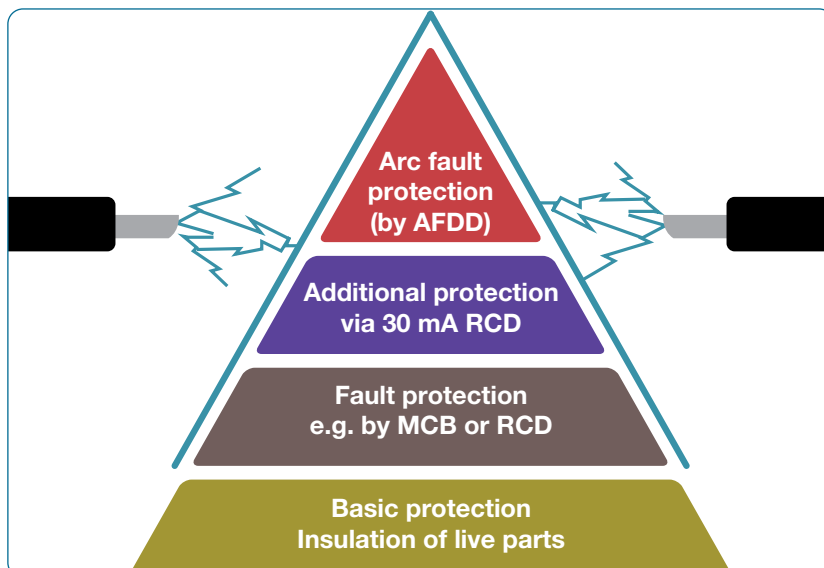

## How Do Insulating Materials Ignite?

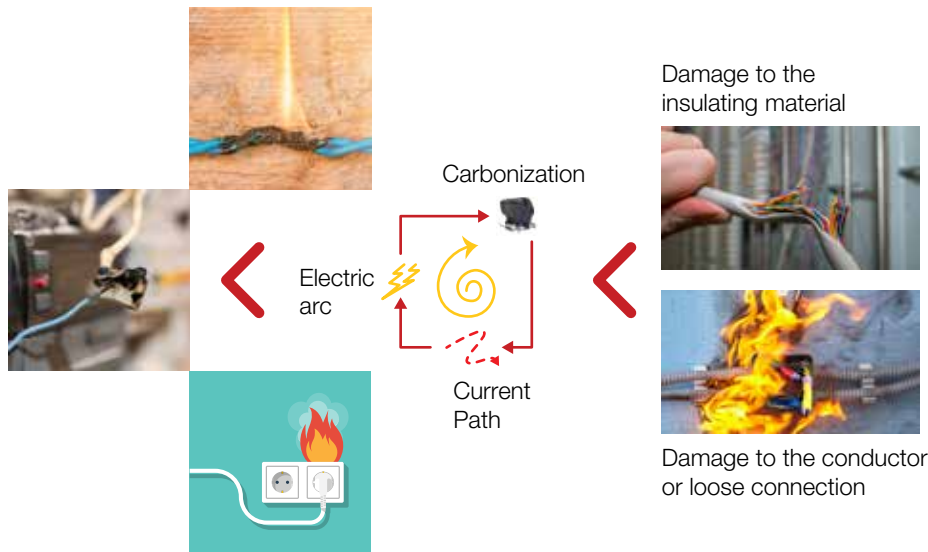

## Arc Fault Classification

As per IEC 62606, an arc is defined as a luminous discharge of electricity across an insulating medium, which usually results in the partial volatilization of the electrodes.

Arc fault is hazardous unintentional arc between two conductors. Such effect in the conductor may cause inflammation of insulation and subsequent setting of a building on fire.

Mechanism	Importance
poor connections	most ↓ least
arcing across a carbonized path	
arcing in air	
excessive thermal insulation	
overload	
ejection of hot particles	
dielectric breakdown in solid or liquid insulators	
miscellaneous phenomena	

The primary circuit breaker like MCB, RCCB and the fuse do not switch off, because they are not able to react to such fault. The current in the circuit, which would have activated the circuit breaker or the fuse remained on the standard operating level because of absence of short circuit or overload. An Arc fault detection device utilizes advanced electronic technology to sense the different arcing conditions.

Table- Physical mechanisms causing electrical fires, ranked according to importance.

## Series Arc Fault

These faults occurs in a live conductor in series with the load. There is no current flowing through the earth or the neutral conductor. The current is further reduced as a result of the arc voltage in series with the load. Hence, RCDs and MCBs are of no use during the occurrence of such a fault.

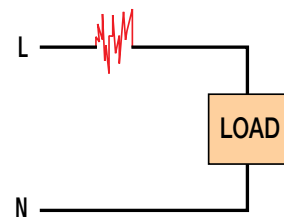

## Parallel Arc Fault

These faults occur between a live conductor and a neutral conductor.

Since no current flows through the earth conductor, RCDs fail to protect during such faults.

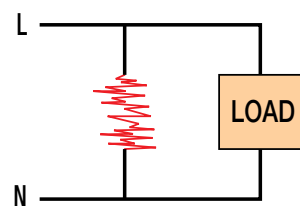

## Earth Arc Faults

This type of arc fault occurs between a live conductor and the earth conductor. An RCD with a maximum rated residual current of 300 mA may be used for such a fault. If the impedance of the faulty circuit is too high, these devices fail to protect the circuit from such faults.

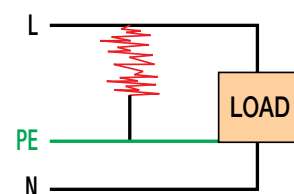

## What Causes Arc Faults?

### 1. Trapped/Crushed Cables

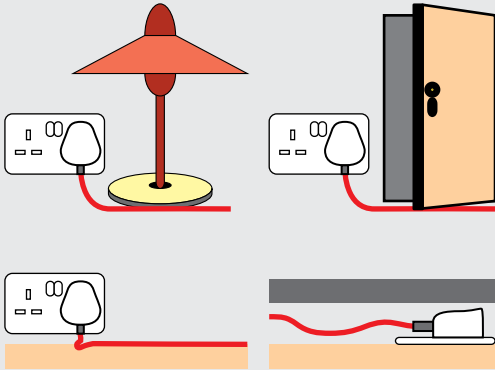

### 2. Rodent Damage



### 3. Pierced Insulation

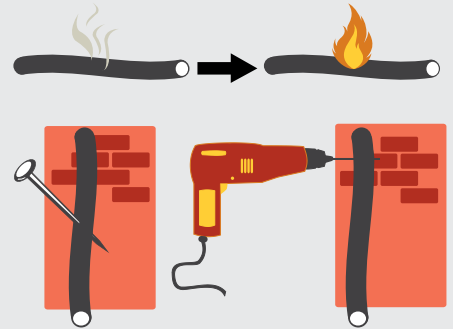

### 4. Deteriorating Insulation by Environment

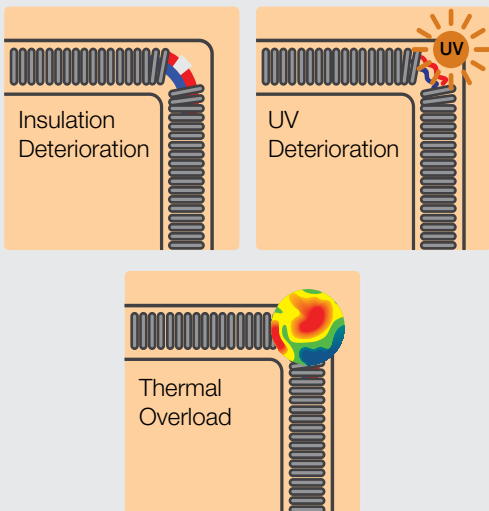

### 5. Damaged Insulation

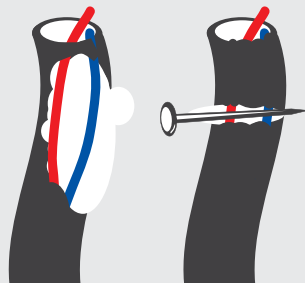

### 6. Loose Terminations

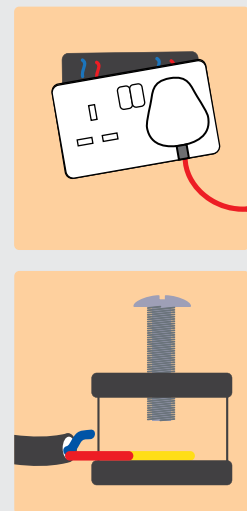

## How Does AFDD Work?

An arc fault has certain characteristics which differentiates it and makes it identifiable.

Unlike a circuit breaker which detects overloads and short circuit currents and RCDs which detect current imbalance, an AFDD utilises electronic technology to analyse the signature (waveform) of an arc to differentiate between normal arcing and arcing faults.

This includes high frequency noise within fault current and breakdown at the zero crossing of the fault current.

AFDD analyses various electrical parameters to ensure that it trips only on dangerous electric arcs and not in normal operation of certain electrical appliances etc.

- The current of the arc (a series arc is dangerous as soon as its value equals or exceeds 2.5 A).
- The duration of the appearance of the arc (very short durations, for example, are characteristic of the normal operation of a switch).
- The irregularity of the arc (the arcs of brushed motors, for example, are fairly regular and as such should not be considered dangerous).
- The distortion of the current signal (sine) at the time of its zero crossing is characteristic of the presence of an electric arc: the current flows only after the appearance of an arc which needs a minimum voltage to be created.
- The presence of disturbances at varying levels of different high frequencies is characteristic of the passage of a current through heterogeneous materials (such as cable insulation).

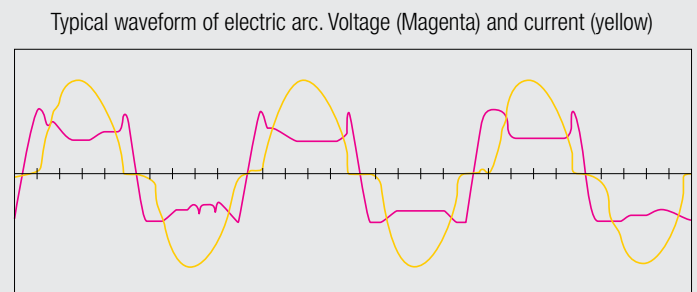
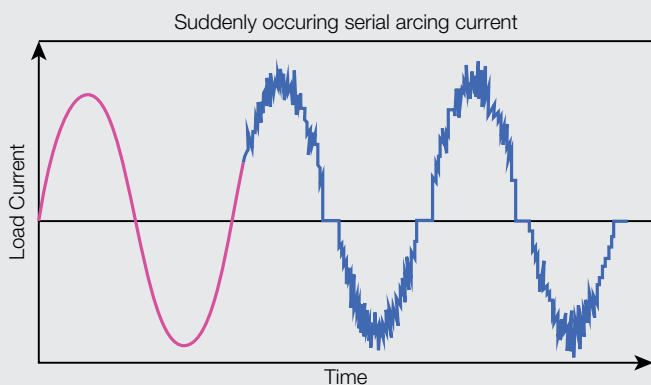



# MCB

## MINIATURE CIRCUIT BREAKER

### Range

0.5 A to 63 A - 'C' Curve

0.5 A to 32 A - 'D' Curve

### Accessories

- Auxiliary Contact
- Under Voltage Trip
- Shunt Trip
- Under Voltage Trip + Time Delayed
- Over Voltage Trip
- Phase Loss
- Under Voltage Trip + Over Voltage Trip

### Execution

Single Pole (1P)

Single Pole & Neutral (1P+N)

Double Pole (2P)

Three Pole (3P)

Three Pole & Neutral (3P+N)

Four Pole (4P)

### Specification

IS/IEC 60898-1

IEC 60898-2 for DC Application

IEC 60947-2 for Industrial Application



WARRANTY\*



IS/IEC 60898-1  
& IEC 60947-2



COMMUNICATION  
READY

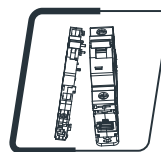

ADD ON  
AUXILIARY



100%  
Recyclable





#### Inscription Window

Ensures circuit identification and hence reduces maintenance downtime



#### Safety Terminals

To avoid improper cable termination, the safety terminals guide the cable towards the cage terminal for systematic termination



#### Large Cable Terminals

Suitable for copper and aluminum cables, these terminals are compatible with cables upto 35 mm<sup>2</sup> cross section area

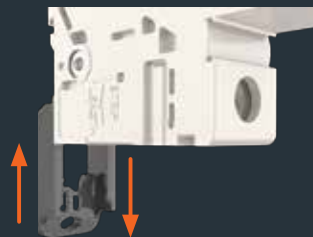

#### Bi Stable Clip

Every device is provided with a dual position DIN rail clip, so it becomes much easier to change a device from a device bank connected to a bus-bar, without disturbing the existing wiring



#### Positive Contact Indication

It clearly indicates contact position through Flag Indication (Red-ON, Green-OFF) thus enhancing safety



#### Field fittable Auxiliary Contacts



## SHUNT TRIP

Shunt trips are devices used for the remote instantaneous opening of the circuit breaker.

Technical Specification				
Standard Conformity	IEC 60947-1			
Rated Voltage (Ue)	AC 110 V-415 V	DC	DC	DC
	DC 110 V-130 V	12 V	24 V	48 V
Frequency	50 Hz/60 Hz			
Max Release Duration	10 ms			
Operational Voltage	70% - 110% Ue			
Coil Resistance	120 Ω			
Terminal Capacity (max)	6 mm <sup>2</sup>			
Mechanical Status Indicator	Front			
Tightening Torque	0.8 N·m			
Dimensions (H x D x W)	88.3 mm x 71 mm x 17.7 mm			
Net Weight	72 g			
Electrical Endurance (no. of operations)	4,000			
Wiring Connection Type	Bottom			
Mounting	Left side of MCB			



## UNDER VOLTAGE TRIP + TIME DELAYED

Causes the device with which it is associated to trip when input voltage decrease (between 70% and 35% of Un). No tripping in case of transient voltage drop (up to 0.2 s).

Technical Specification	
Phase	Single phase / Three phase
Standard Conformity	IEC 60947-1
Rated Voltage (Ue)	240 V ac / 415 V ac
Frequency	50 Hz/60 Hz
Under Voltage Trip Voltage	$0.35 U_e \geq V \geq 0.7 U_e$
Trip Delay	0.2 s
Terminal Size	6 mm <sup>2</sup>
Protection Degree	IP20
Mechanical Status Indicator	Front
Tightening Torque	0.8 N·m
Dimensions (H x D x W)	88.3 mm x 71 mm x 17.7 mm
Net Weight	78 g / 90 g
Electrical Endurance (no. of operations)	4,000
Wiring Connection Type	Bottom / Top
Mounting	Left side of MCB



## OVER VOLTAGE TRIP

Cuts off the supply power by opening with which it is associated when the phase & neutral voltage is exceeded.

Technical Specification	
Phase	Single phase / Three phase
Standard Conformity	IEC 60947-1
Rated Voltage (Ue)	240 V ac / 415 V ac
Frequency	50 Hz/60 Hz
Max Non-Tripping Voltage	255 V ac
Max Tripping Voltage	280 V ac
Max Duration of Impulse Command	10 ms
Terminal Size	6 mm <sup>2</sup>
Protection Degree	IP20
Mechanical Status Indicator	Front
Tightening Torque	0.8 N·m
Dimensions (H x D x W)	88.3 mm x 71 mm x 17.7 mm
Net Weight	78 g / 90 g
Electrical Endurance (no. of operations)	4,000
Wiring Connection Type	Bottom / Top
Mounting	Left side of MCB



## PHASE LOSS

Causes the device with which it is associated to trip when input voltage decreases below 70 % of Un. It will also trip the associated device on the power failure or in case voltage reaches nearly 0 volts.

Technical Specification	
Phase	Single phase
Standard Conformity	IEC 60947-1
Rated Voltage (Ue)	220 V ac - 240 V ac
Frequency	50 Hz/60 Hz
Under Voltage Trip Voltage	$0 U_e \geq V \geq 0.7 U_e$
Terminal Size	6 mm <sup>2</sup>
Protection Degree	IP20
Mechanical Status Indicator	Front
Tightening Torque	0.8 N·m
Dimensions (H x D x W)	88.3 mm x 71 mm x 17.7 mm
Net Weight	78 g
Electrical Endurance (no. of operations)	1,000
Wiring Connection Type	Bottom
Mounting	Left side of MCB

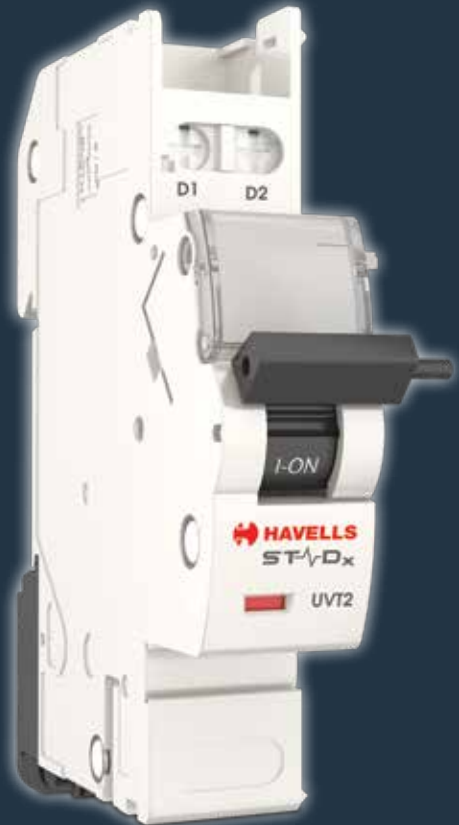

## UNDER VOLTAGE TRIP + OVER VOLTAGE TRIP

Cuts the supply power by opening with which it is associated when the phase & neutral voltage is in not with in the limits.

Technical Specification	
Phase	Single phase / Three phase
Standard Conformity	IEC 60947-1
Rated Voltage (Ue)	240 V ac / 415 V ac
Frequency	50 Hz/60 Hz
Max Non-Tripping Voltage	255 V ac
Max Tripping Voltage	280 V ac
Under Voltage Trip Voltage	$0.35 U_e \geq V \geq 0.7 U_e$
Max Duration of Impulse Command	10 ms
Terminal Size	6 mm <sup>2</sup>
Protection Degree	IP20
Mechanical Status Indicator	Front
Tightening Torque	0.8 N·m
Dimensions (H x D x W)	88.3 mm x 71 mm x 17.7 mm
Net Weight	78 g / 90 g
Electrical Endurance (no. of operations)	4,000
Wiring Connection Type	Bottom / Top
Mounting	Left side of MCB





# MCB

## HIGHER CURRENT MCB (80 A - 125 A)

### Range

80 A, 100 A & 125 A - 'C' Curve

### Execution

Single Pole (1P), Double Pole (2P)

Three Pole (3P), Four Pole (4P)

### Specification

IS/IEC 60947-2 & IEC 60947-2



WARRANTY\*



IS/IEC 60947-2  
& IEC 60947-2



100%  
Recyclable



Reliable



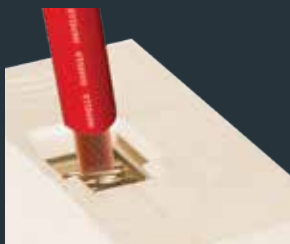

#### Large Cable Terminals

Suitable for copper and aluminum cables, these terminals are compatible with cables upto 35 mm<sup>2</sup> cross section area



#### Safety Terminals

To avoid improper cable termination, the safety terminals guide the cable towards the cage terminal for systematic termination



#### Positive Contact Indication

It clearly indicates contact position through Flag Indication (Red-ON, Green-OFF) thus enhancing safety



# RCCB

## RESIDUAL CURRENT CIRCUIT BREAKER

**Range**  
16 A - 100 A

**Sensitivity**  
30 mA, 100 mA & 300 mA

**Execution**  
Double Pole (2P)  
Four Pole (4P)

**Specification**  
IS 12640 Part 1/IEC 61008-1 / EN 61008 - 1 / IEC 62423



WARRANTY\*



IS 12640 (PART-1)  
& IEC/EN 61008-1



COMMUNICATION  
READY

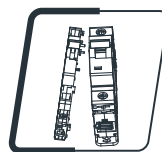

ADD ON  
AUXILIARY



100%  
Recyclable



Reliable



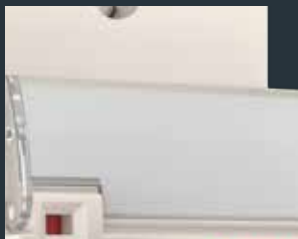

#### Inscription Window

Ensures circuit identification and hence reduces maintenance downtime



#### Large Cable Terminals

The terminals are suitable for cables up to 35 mm<sup>2</sup> cross section area. Thus making it suitable for copper and aluminium cables



#### Safety Terminals

They guide the cable towards the cage terminal and avoid improper cable termination



#### Bi Stable Clip

Every device is provided with a dual position DIN rail clip, so it becomes much easier to change a device from a device bank connected to a bus-bar, without disturbing the existing wiring



#### Dual Termination

Two types of busbars can be used, that is, Fork Type and Pin Type



Test button for regular inspection/testing







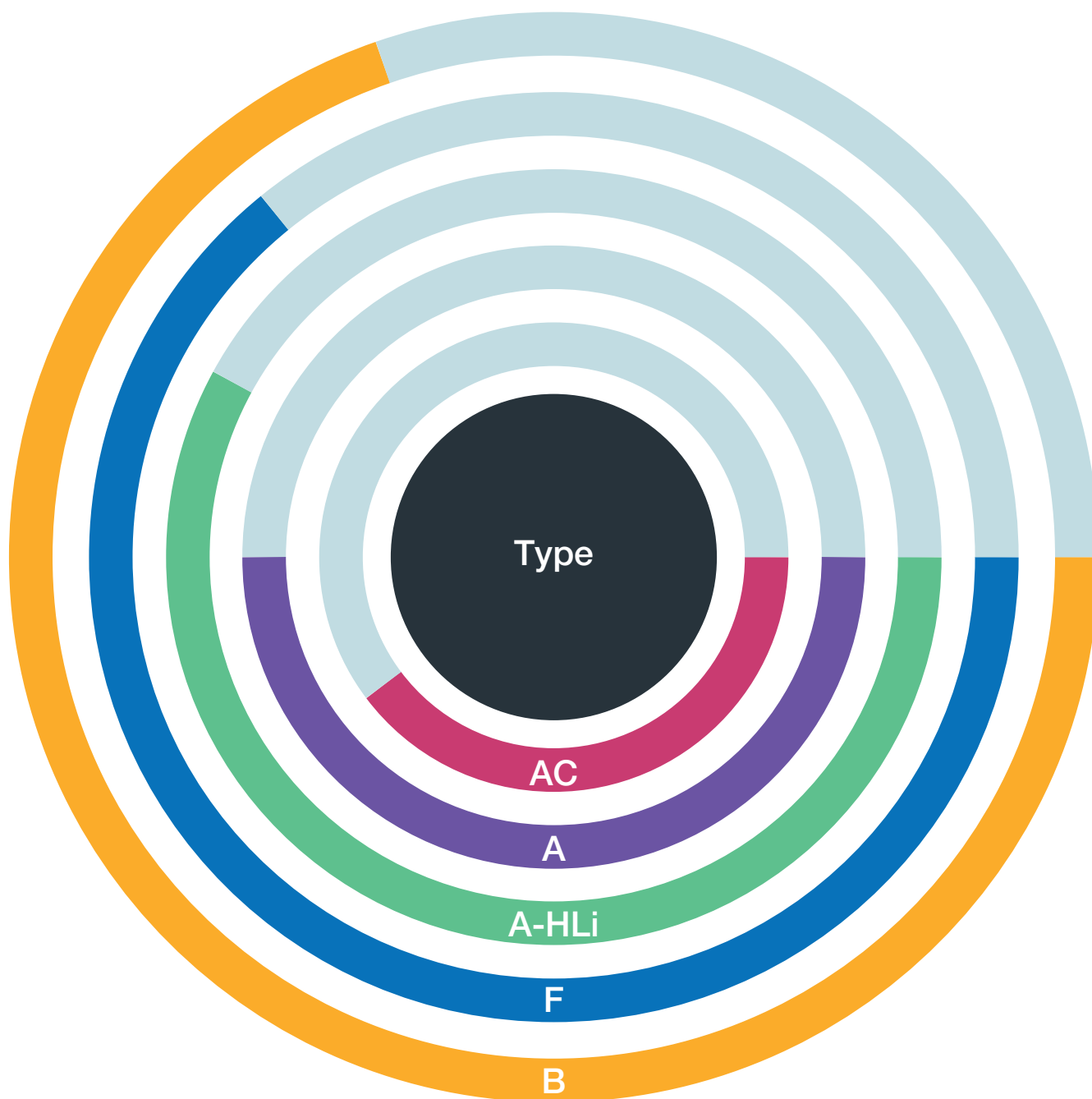

## PRESENTING HAVELLS STADx RANGE RCDs

With the Technology evolution and massive introduction of electronics in all fields of application result in earth leakage current with different waveform characteristics.

According to the capability to detect different waveforms of residual current, today the spectrum of RCDs covers from pure AC loads upto high frequency and DC related applications with an increasing level of protection passing from AC Type upto F and B Type.





- Type AC**     **Alternating Current Only.**
  
- Type A**     **Full Type AC Features.**  
 + Detection of Pulsating Current with DC Components.
  
- Type A-HLi**  **Full Type A Features.**  
 + High Immunity to unwanted tripping.
  
- Type F**      **Full Type A-SI Features.**  
 + Detection of High Frequency Currents up to 1 kHz.
  
- Type B**       **Full Type F Features.**  
 + Detection of Smooth DC Currents.



# RCBO

## RESIDUAL CURRENT CIRCUIT BREAKER WITH OVERLOAD & SHORT CIRCUIT PROTECTION

### Execution

Electromechanical RCBO (SPN & 2P RCBOs)  
Electromechanical RCBO (TPN & FP RCBOs)

### Range

16 A, 25 A, 32 A, 40 A & 63 A

### Specification

IS 12640 : Part 2/IEC 61009-1/EN : 61009-1

### Sensitivity

30 mA, 100 mA & 300 mA



WARRANTY\*



IS 12640 (PART-2)  
& IEC/EN 61009-1



100%  
Recyclable



Reliable





**Test Button**  
Test button for regular inspection/testing



**Proper Cable Termination**  
Proper cable termination with 25 mm<sup>2</sup> slot and safety shutter



**Inscription Window**  
Inscription window with ON & OFF indication



# SPD

## SURGE PROTECTION DEVICES

### Range

AC SPD's

Type 1+2

Type 2

Type 3

DC SPD's

Type 1+2

Type 2

### Specification

IEC 61643-11: 2011, EN 61643-11: 2012

IEC 61643-21



IEC/EN 61643-11  
& IEC 61643-21



100%  
Recyclable



Reliable





#### Remote Signaling Contact

- Option to remotely monitor the status of the surge protector.
- Simplified cabling thanks to a single terminal for monitoring all poles.



- Satisfactory operation
- Cartridge must be replaced

#### End of Life Indicator

Green shows the satisfactory operation and Red indicates that Cartridge must be replaced.



#### Pluggable Cartridges

Every device is provided with a dual position DIN rail clip, so it becomes much easier to change a device from a device bank connected to a bus-bar, without disturbing the existing wiring



#### Dedicated Protection of the Neutral

The 1 P+N and 3 P+N SPDs with dedicated protection of the neutral pole discharge the common and differential mode overvoltages that may occur in installations with TT and TNS systems, when there is a voltage surge.



# TIME SWITCH

## ALL NEW RANGE OF TIME SWITCH

Havells introduces an advanced range of time switches. It is used in residential, commercial and industrial premises to improve comfort and save energy by switching loads automatically as per real time. The range offers a variety of feature benefits such as controlling the opening and closing of electrical circuits according to a scheduled program, minimum switching time, internal battery to enable the timing function in case of power failure along with daily, weekly and annual versions with simple and compact design. It will help in the optimization of energy. Once installed they can program a schedule for a limited period or permanently to help optimize how and when energy is used.

### Features

- Digital time switch with daily and weekly program
- Text-oriented user guidance in display
- 3 year power reserve (For multifunction time switch 10 year power reserve)
- Automatic summer/winter time changeover
- Preset date and time
- Holiday program
- Permanent switching ON/OFF for better user experience.
- Reset option
- Programmable in 5 languages





## Digital Weekly Time Switch

The digital time switch is used for realization of time functions in the control systems and automation. It operates according to the set time schedule planned by the user. There is an internal battery which can protect real time clock and all the settings in case of electricity failure. Depending on the day of the week (Mon-Sun) different daily programs can be configured.

### Features

- Digital time switch with daily and weekly programming.
- Interactive LCD display for better user experience.
- Battery backup of 3 years.
- Single channel.
- Easy to program.
- Different operating modes: Holiday, Auto, Manual.
- Permanent ON/Permanent OFF setting
- DIN rail mountable.



## Astronomical + Digital Time Switch

Astronomical digital time switch is for realization of time functions in the systems of automatics and steering. It calculates the sunrise and sunset time in the set geographic area and time zone, without the use of a photocell sensor. There is an internal battery which can protect real time clock and all the settings when the electric power supply is off.

### Features

- Astronomical and digital daily/weekly/annually programming.
- Interactive LCD display with backlight for better user experience.
- Easy to program.
- Latitude and longitude setting.
- Offset to adjust sunrise and sunset times.
- Battery backup of 3 years.
- Different operating modes: Holiday, Random, Auto, Manual.
- Permanent ON/Permanent OFF setting.
- DIN rail mountable.



## 24 Hours Analog Time Switch

24-Hours Analog Time Switch has a 24-hours dial and is used to switch an electrical circuit "ON" or "OFF" at selected times, during the day, programmed in advance. The start of the program has to be set on the dial by pulling a segment on the desired time.

### Features

- Electromechanical general purpose time switch with daily programs.
- Repeat programs with 48 ON/OFF settings.
- Minimum switching time of 15 minutes & 30 minutes.
- Cover for protecting the LCD from mechanical shocks and scratches.
- Din rail mountable.





# ISOLATOR

## MCB ISOLATOR SWITCHING DEVICES

### Range

40 A-63 A  
100 A-125 A

### Execution

Double Pole (2P)  
Three Pole (3P)  
Four Pole (4P)

### Specification

IS/IEC 60947-3



WARRANTY\*



IS 12640 (PART-1)  
& IEC/EN 61008-1



COMMUNICATION\*\*  
READY

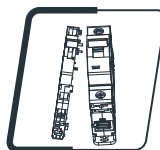

ADD ON\*\*  
AUXILIARY



100%  
Recyclable



Reliable

\*\* upto 63 A rating devices range.





#### Large Cable Terminals

Suitable for copper and aluminum cables, these terminals are compatible with cables having cross-section area upto 35 mm<sup>2</sup> (below 63 A) and upto 50 mm<sup>2</sup> (100 A-125 A)



#### Safety Terminals

To avoid improper cable termination, the safety terminals guide the cable towards the cage terminal for systematic termination



#### Bi Stable Clip

Every device is provided with a dual position DIN rail clip, so it becomes much easier to change a device from a device bank connected to a bus-bar, without disturbing the existing wiring



#### Cooler Operation

Grooves provided on outer body, so that when individual poles are placed adjacent to each other in a distribution board it forms a very effective channel for better air circulation, resulting into a cooler operation



# ACCL

## AUTOMATIC CHANGEOVER WITH CURRENT LIMITER

### Range

Mains 40 A/63 A/80 A, Gen 10 A-80 A (TPN)  
Mains 30 A/Gen 1.5 A to 20 A (SPN)  
Mains 63 A/Gen 63 A (Automatic Changeover)

### Execution

Three Pole with Neutral (TPN)  
Single Pole with Neutral (SPN)

### Specification

IEC 60947-6-1



IEC 60947-6-1



100%  
Recyclable



Reliable





#### Reset Button

Manual reset provision for restoring supply, when in sleep mode



#### Mountable in Distribution Boards

Modular design - easy to mount in distribution boards



#### LEDs indication

Operational Status Indication through LEDs- Mains ON, Genset ON, Genset Overload etc.



#### Cable Terminals

Staggered terminal design with bottom wiring for better isolation between phase & neutral

# Automatic Source Changeover Devices

## SPN ACCL

Havells offers SPN ACCL for single phase systems - fully automatic high precision microcontroller based source changeover devices which also have current limiting function and offer easy and 'controllable' changeover between main power supply and generator supply. They are ideally suited for efficient utilization of standby generator used in multi-storied apartments, commercial complexes etc.

## Functions

### 1. When the Mains Supply is available:

The ACCL allows unrestricted supply from Mains.

### 2. When Mains supply Fails:

When the mains supply goes OFF, a consumer is automatically connected to generator in case generator supply is available after a time delay of 8 seconds to 12 seconds in order to limit the sudden load on generator.

### 3. Once the Supply goes to generator side then:

- (a) ACCL limits the user from drawing excess load current beyond the limit.
- (b) If the current exceeds the allowable limit the ACCL will indicate the overload condition by blinking the generator LED. Due to this the load is disconnected after a delay of 5 seconds and will remain disconnected for 8 seconds as a warning then automatically reconnects. During this period, the consumer is expected to switch off the non-essential loads and reduce it within limit. this cycle will continue till overload condition exists.



## TPN ACCL

Havells offers TPN ACCL for three phase systems - fully automatic high precision microcontroller based source changeover devices which also have current limiting function and offer easy and 'controllable' changeover between main power supply and generator supply. They are ideally suited for efficient utilization of standby generator used in multi-storied apartments, commercial complexes etc.

### Functions

#### 1. When mains supply is available

The device will run the load on mains supply if the R phase is available irrespective of the availability of all other phases. It is recommended to connect the entire essential load to R phase.

#### 2. When mains supply fails

If mains supply goes off (detected by R phase), the device will automatically sense and actuate the inbuilt changeover mechanism to the generator supply. This takes 8 seconds-12 seconds so as to avoid sudden loading on generator. TPN ACCL also allows user to opt for manual mode for manual transfer of load to gen-set.

Current Limiting feature on Generator side: If load current exceeds the preset allowable limit, then Overload LED will start glowing, but load will remain connected for 5 seconds to ignore the surge current. But if load still persists beyond the preset limit, it is disconnected for 8 seconds as a warning and then automatically reconnected. Such cycle of interruptions continue for a number of times during which the user is expected to switch off nonessential loads.

#### 3. When mains supply restores

On resumption of mains, the load is automatically transferred to main supply after a time delay of 2 seconds-4 seconds.





# MODULAR CONTACTOR

Nowadays there is a growing trend of automation processes in building wiring and installation. Thus there is a need for compact and energy efficient load controlling devices which can be integrated in the existing building infrastructure. Havells has designed a wide range of Modular Contactors for centralized control and remote switching of electric devices used in buildings such as hotels, hospitals, shopping centers, offices, public buildings, sport centers, domestic applications etc. They are used for remotely controlling electric circuits for lighting, HVAC, pumps and other building automation systems. Modular Contactors are the latest offering in Havells Euro II range of control and protection devices. Available in 16 A-63 A rating, single pole or multi-pole, automatic and manual versions and having various contact configurations, the range offers a complete package for meeting diverse application needs of modern times.



IEC/EN 61095



COMMUNICATION  
READY

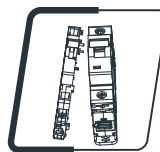

ADD ON  
AUXILIARY



100%  
Recyclable





**Safety Terminals**

To avoid improper cable termination, the safety terminals guide the cable towards the cage terminal for systematic termination.



**Built-in Manual Override Handle**

Provides a provision to operate the contactor in 3 function modes - Auto, Manual ON and Manual OFF.



**Finger Touch Protection**

IP20 Terminals

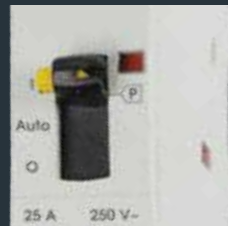

**Mechanical Contacts Position Indicator:**

RED when ON.  
Quick identification of operating status.



**Retro Fittable Auxiliary**

Simple Clip-ON System, Toolfree Association with Device



**Dual Stage Clamp** for easy mounting & extraction from DIN rail.

**Flexibility Installation** Vertical / Horizontal positions

## AUTOMATIC MODULAR CONTACTOR WITH MANUAL OVERRIDE

Automatic Contactors with manual override knob have a manual over-ride switch to select between three function modes and 4 operating positions.

- Automatic Mode: It is the normal operating mode i.e. Contactor is operational (ON) when Coil voltage is applied and vice versa.
- ON Mode :
  - Temporary "ON" position: When manual knob is not locked at ON position – the main contacts remain ON as long as coil supply is absent. When coil supply becomes available, the contactor automatically reverts to automatic mode.
  - Permanent "ON" position: Here, the contactor is operational (ON) irrespective of the availability of coil supply.
- OFF Mode: Here, the contactor is shutdown irrespective of the availability of coil supply.

Manual override option provides customers with the following features:

- Functional test prior to start/commissioning
- High degree of safety and availability in case of automation system failure
- Testing or repairs can be carried out safely, reliably and quickly without interrupting other automatic functions.
- Force ON and Force OFF feature allows user to run high energy load during low tariff periods only, thereby overruling the normal operation of contactor at all times.

### Quality Features

- Retro Fittable Auxiliary: Simple Clip-ON System, Toolfree Association with Device.
- Built-in Manual Override Handle: Provides a provision to operate the contactor in 3 function modes - Auto, Manual ON and Manual OFF.
- Mechanical Contacts Position Indicator: RED when ON.
- Quick identification of operating status.
- Reduced Noise: Leads to better comfort in building segment applications.
- Optimal quality of contacts and low heat dissipation ensures a long life time.

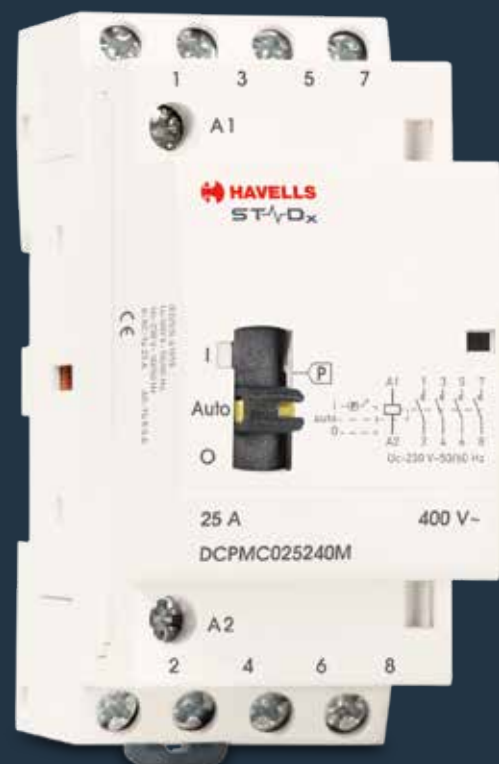

## AUXILIARY CONTACT

This Auxiliary allows indication of the “OPEN” or “CLOSED” position of the contactor power contacts. Auxiliary changeover contacts i.e. 1 NO/1 NC version is available which can be fitted on the right side of the device without needing any tools.

Technical Specification	
Type	Indication
Standard Compliance	IEC 60947-5-1
Contacts Configuration	1 NO+1 NC
Mounting	On the right side of the contactor
Control Voltage	AC-12-240 V, AC-15-230 V, DC-13-130 V
Operating Frequency	50 Hz/60 Hz
Contacts (Breaking capacities)	5 A at 240 V ac, COS $\Phi = 1$ , 2 A at 230 V, COS $\Phi = 1$ , 1 A at 130 V dc
Operating Temperature	-5 °C to 50 °C
Storage Temperature	-40 °C to 70 °C
Insulation Voltage	500 V
Terminal Capacity	2.5 mm <sup>2</sup>
Product Code	DSSRCX0147

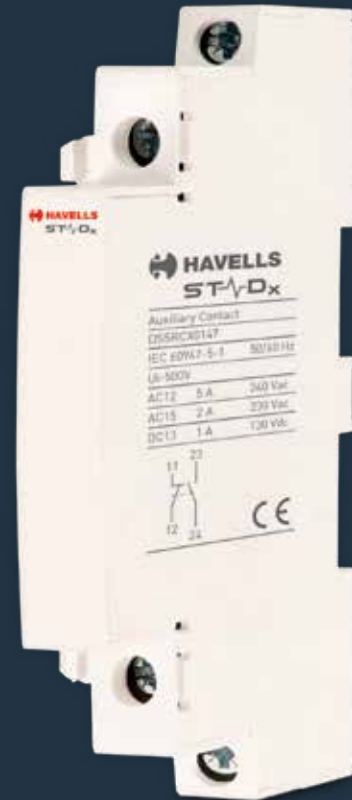



# DB

## IP 43 DISTRIBUTION BOARD

After the huge success of the Metalica and QVE Distribution Board ranges, Havells is set to launch a new distribution board range – IP43.

Much like their title, these distribution boards will add to the beauty of our walls, our homes. The new series has been designed to cater the aesthetic needs of one's home while maintaining the performance standards and simplicity of use requirements.

IP43 has been engineered to ensure safety of electrical appliances as well as human life from electrical hazards, while giving the user the opportunity to stand out among his peers.



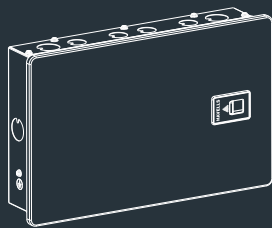

Metal door with rounded corners



Door reversible

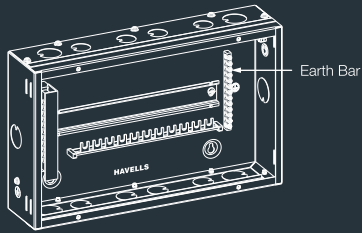

Door Earthing

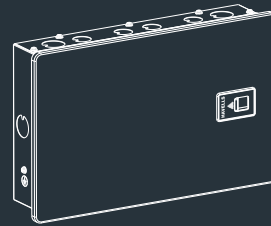

IK 09 & IP 43

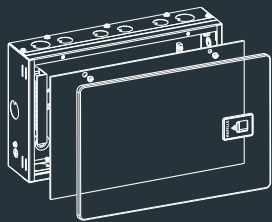

Three Piece Design

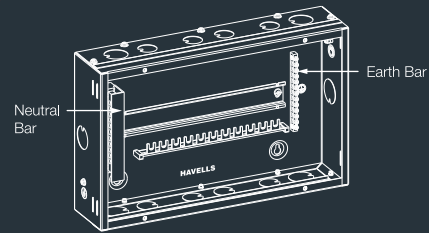

Neutral & Earth bar on left & right side of box for ease of wiring

## COMMUNICATION DB

This DB is a part of communication ready switchgear range. It is a spacious DB for mounting devices, auxiliaries, STADx Bridge, STADx Bar and other accessories.

### Features

- Available in 4 different variant from 1 row to 4 way
- It has windows on internal plate to see the indications and address of the STADx Bridges installed in it.
- It has provision to mount antenna on cover to ensure better wireless connectivity.
- It has proper mounting locations and spaces for STADx communication range.



## IP 43 DISTRIBUTION BOARD

### Range:

SPN – 6 Ways, 8 Ways, 12 Ways & 16 Ways

TPN – 4 Ways ECO, 4 Ways, 6 Ways, 8 Ways & 12 Ways

### Variant:

FLEXI TIER DD Distribution Board

PHASE SELECTOR Distribution Board

PPI TPN HORIZONTAL DD Distribution Board

PSG 8 SEG Distribution Board

VTPN Modular Incomer Distribution Board

VTPN with MCCB Incomer Distribution Board

### Specification:

IEC 61439-3, IS: 13032 IS: 8623

### Features:

- Metal door with rounded corners
- Door reversible
- Door Earthing
- IK 09
- IP 43
- Three Piece design
- Neutral & Earth bar on left & right side of box for ease of wiring
- Suitable for surface & flush mounting
- Supplied with fully shielded bus bars
- Level marks for providing indication for fitment in the wall
- Supplied with masking sheet to protect components from cement during plastering



# Technical Specification

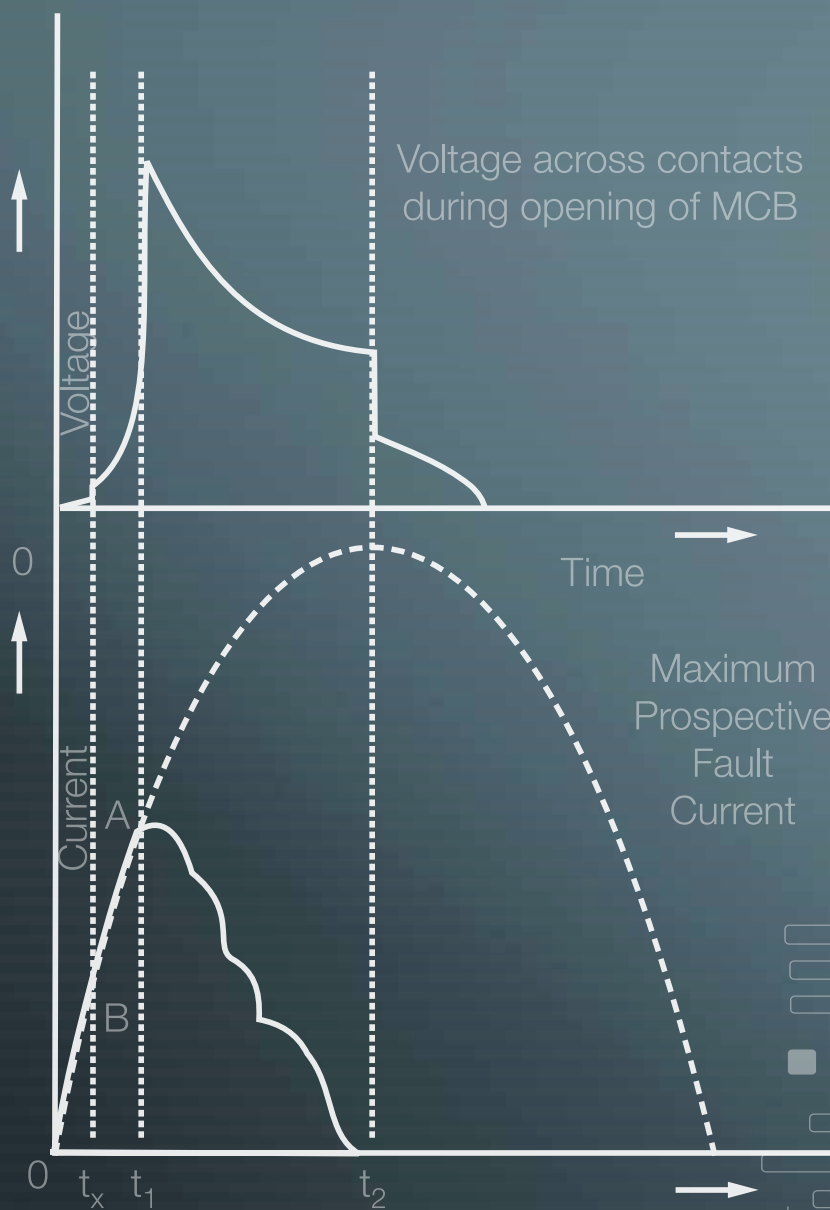

STADx Bridge.....	88	Miniature Circuit Breaker (80 A-125 A) .....	128
• STADx Bridge-Wired.....	90	Residual Current Circuit Breaker .....	129
• STADx Bridge-Wireless.....	90	RCCB Higher Rating (80 A-100 A) .....	136
Aux MCB & RCCB.....	91	Residual Current Circuit Breaker With	
Aux Contactor .....	93	Overload & Short Circuit Protection .....	138
Recloser MCB & RCCB.....	95	Surge Protection Device .....	140
Aux MCCB .....	98	• Type 1+2 AC Surge Protection Devices .....	140
STADx Dongle .....	100	• Type 2 AC Surge Protection Devices.....	142
• Stadx Dongle Wireless.....	100	• Type 3 Surge Protection Devices .....	144
• Stadx Dongle Wired.....	101	• Type 1+2 Photovoltaic Surge Protection Devices .....	146
• Stadx Extend .....	102	• Type 2 Photovoltaic Surge Protection Devices .....	148
• Stadx Transmuter .....	103	• Type 2 DC 600 V Surge Protection Devices .....	150
STADx Energy Meters		Time Switch .....	152
• Energy Meter - 1P 1M .....	104	• Digital Weekly Time Switch .....	152
• Energy Meter - 1P 2M .....	106	• Astronomical + Digital Time Switch .....	154
• Energy Meter - 3P .....	108	• 24 Hours Analog Time Switch.....	156
STADx Bar.....	111	Isolator .....	158
AFDD (Arc Fault Detection Device).....	112	Isolator (80 A-125 A).....	159
Miniature Circuit Breaker.....	114	Automatic Source Changeover Devices.....	160
Auxiliary Contact.....	124	• ACCL - SPN .....	160
Shunt Trip.....	124	• ACCL - TPN .....	162
Under Voltage Trip .....	125	Modular Contactor .....	164
Under Voltage Trip + Time Delayed.....	125	Auxiliary Contact.....	167
Over Voltage Trip .....	126	• Automatic Modular Contactor With Manual Override....	168
Under Voltage Trip + Over Voltage Trip.....	126	Distribution Board.....	175
Phase Loss .....	127	Product Codes .....	200

# STADx BRIDGE

- STADx Bridge can be used as a standard I/O distributed module.
- STADx Bridge is equipped with 11, 24 V dc channels. Each channel is represented by a wired interface consisting of:
  - Two pins: 0 V and 24 V dc
  - Two 24 V dc logic inputs (F1 and F2)
  - One 24 V dc logic output (C)
  - Can be connected to communication ready devices which consists of metering, monitoring and controlling devices.
- The STADx Bridge communication system is simple and safe to use.
- The STADx Bridge communication system pre-wired cables reduce complexity and wiring time by allowing connection on an STADx Bridge module of all the STADx Bridge communication system components and 24 V dc compatible products.

All STADx communication system functions can be programmed by sharing data packets with stadx bridge through wired (RS485 communication) or wireless (RF interface).





The feedbacks from auxiliary & local LED indications are interpretable as below:

- The STADx Bridge device has 11 channels and can be connected to devices in the communication ready range equipped with a wired interface.
- Data can be transmitted from the STADx Bridge device to a PLC system via a RS485 communication network.
- The STADx Bridge device channels can also be used to transmit standardized I/O. The STADx Bridge device can also therefore communicate with devices (not in the Communication ready range) with or without a pre-fabricated cable.

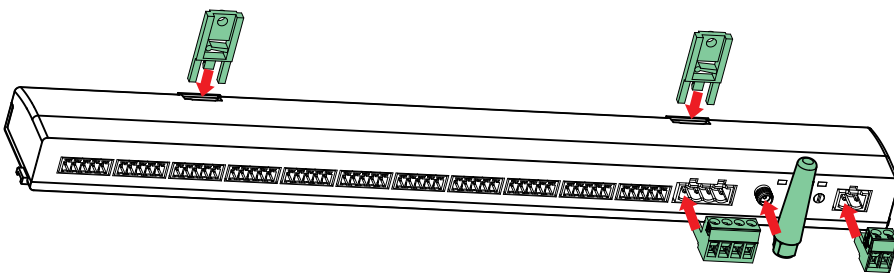

## Product Fitment



Parts	Code	Quantity
	DSSRCX0191	2
	DSSRCX0192	1
	DSSRCX0194	1
	DSSRCX0195	1

\* Only for wireless CommX Bridge

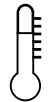

-25 °C to +60 °C



### Technical Specification

Characteristics	Value
Temperature	-25 °C... +60 °C
Tropicalization	Execution 2 (relative humidity of 93% at 40 °C)
Resistance to voltage dips	10 ms, class 3 according to IEC61000-4-29
Degree of Protection	IP20
Level of pollution	3
Overvoltage category	OVC II
Altitude	0...2,000 m
Immunity to vibration	1 g/±3.5 mm, 5...300 Hz, 10 cycles
Immunity to mechanical shock	15 g/11 ms
Immunity to electrostatic discharge	Air: 8 kV, Contact: 4 kV
Immunity to radiated electromagnetic interference	10 V/m - 80 MHz to 1 GHz , 3V/m- 1.4 GHz to 6 GHz
Immunity to fast transients	0.5 kV for the I/O and Modbus communication. 0.5 kV for the 24 V dc - 0.5 kHz - 100 kHz power supply
Immunity to conducted magnetic fields	3 V from 150 kHz to 80 MHz
Immunity to magnetic fields at line frequency	30 A/m continuous 100 A/m pulse
Fire withstand for live parts	30 s at 960 °C. IEC 60695-2-10 and IEC 60695-2-11
Salt mist IEC 60068-2-52	Severity 2

### Communication Module (RS485)

Characteristics	Value
Type of interface module	Modbus RTU (RS485, RF)
Transmission	19 200 Baud
Structure	Modbus
Max. length of Modbus line	1,000 m
Type of bus connector	4-pin connector
Power supply	Non-isolated 24 V dc with protection against negative voltages up to -28.8 V dc
Voltage limits	19.2 V dc...28.8 V dc with ripple
Current consumption, no load	45 mA (Wired variant), 65 mA (Wireless variant)
Maximum input intensity	1.5 A
Maximum current inrush	3 A (limited internally)
Number of digital I/O channels	11

### Input

Characteristics	Value
Number of logic inputs	22 (2 per channel)
Rated input voltage	24 V dc
Input type	Current sink, type 1 IEC 61131-2
Weight (0 V)	1 for 2 inputs (1 per channel)
Input voltage limits	19.2 V dc...28.8 V dc
Rated input current	2.5 mA
Maximum input current	5 mA

Output	
Characteristics	Value
Number of logic outputs	11 (1 per channel)
Logic output	Current source, 24 V dc 0.1 A IEC 61131-2
Weight (0 V)	1 N
Rated output voltage	24 V dc (100 mA)
Voltage drop	1 V max.
Maximum current inrush	500 mA
Leakage current	0.1 mA
Overvoltage protection	33 V dc
Short-circuit protection	Yes
Overload protection	Yes
Current limiting	Yes

## Dimensions (in mm)

### STADx Bridge-wired

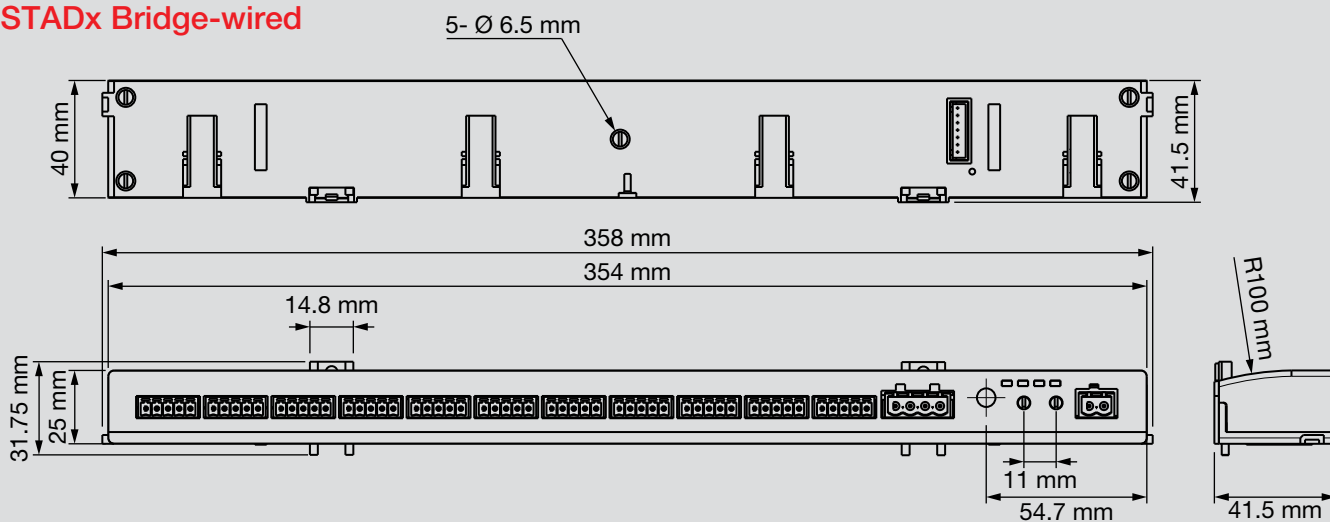

### STADx Bridge-wireless

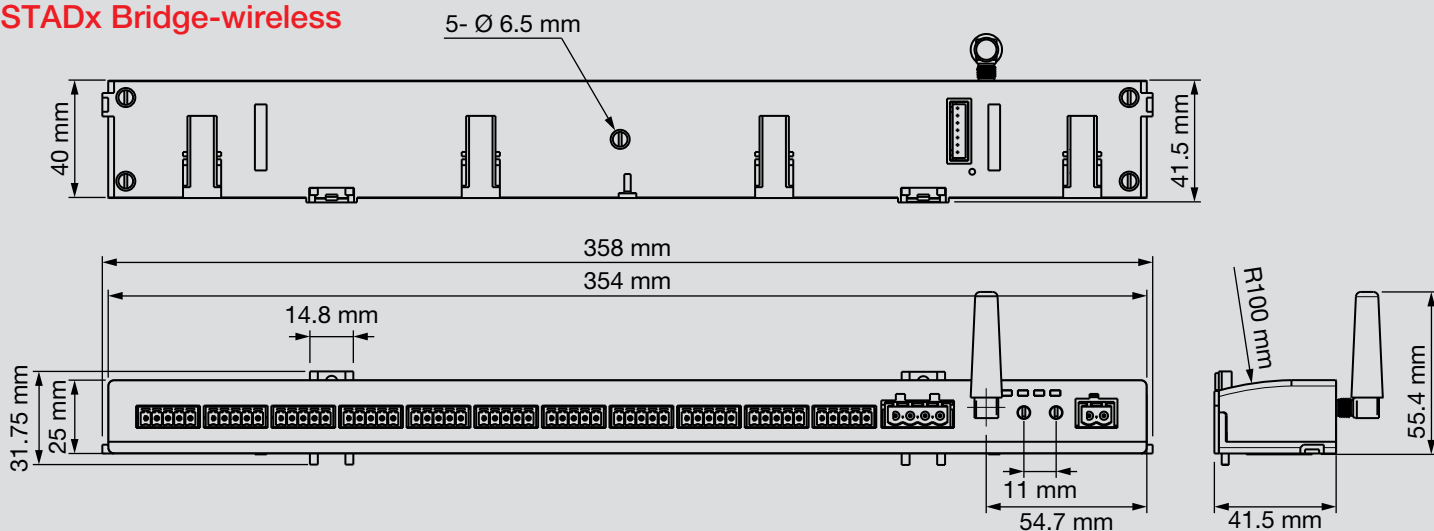

## AUX MCB & RCCB

Ax & AI are the feedbacks sent to STADx Bridge (They are inputs for the latter). They tell whether MCB/RCCB is ON or OFF and if it is OFF, then whether it has been manually turned OFF or it has tripped due to fault.

The middle pin of connector (3.81 mm) is not in use here as there is no control command signal from STADx Bridge to auxiliary.

The auxiliary receives its 24 V dc operating power supply from STADx Bridge itself. It need not be powered up separately.

### Circuit Diagram

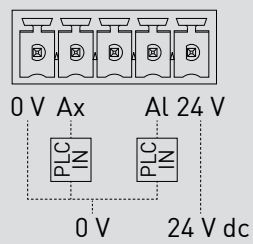

### Dimensions (in mm)

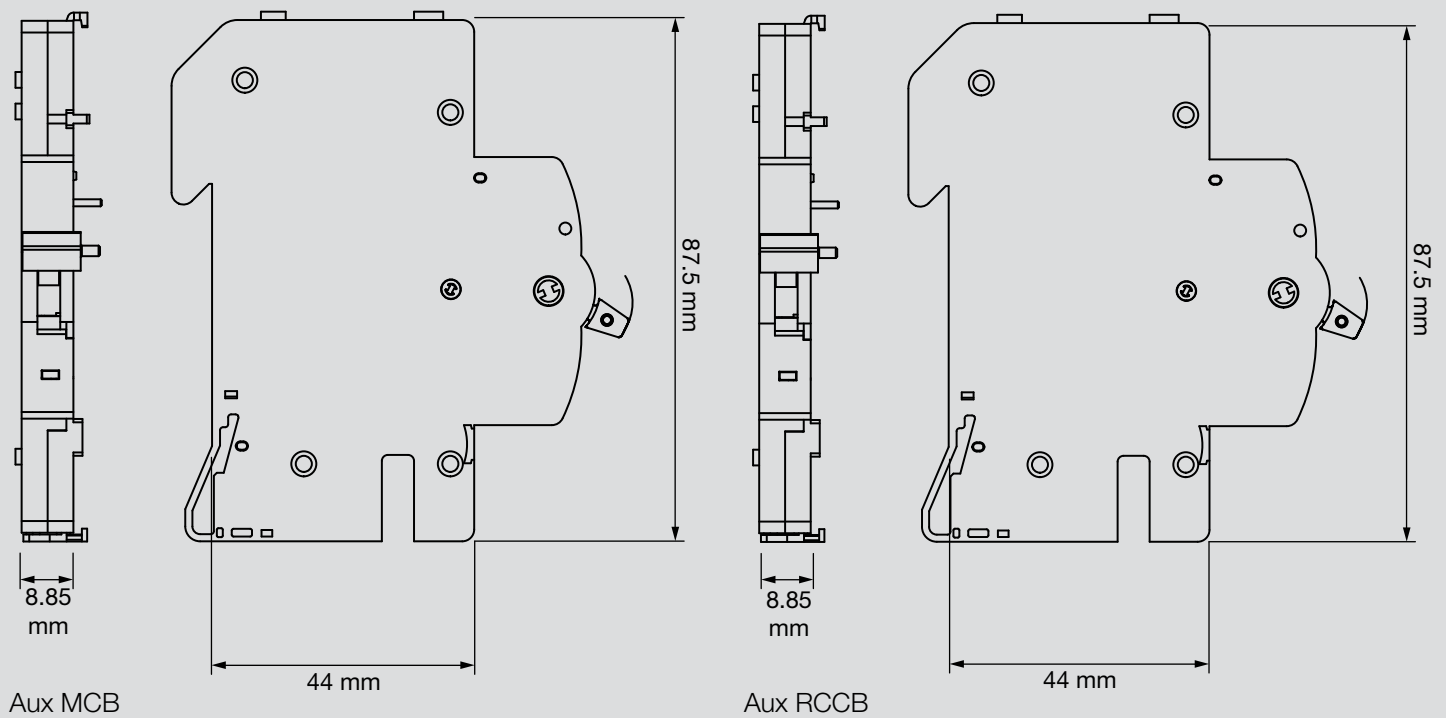

## Technical specifications

Product Type	Aux MCB Ax+AI, Ax, AI & RCCB Ax+AI, Ax, AI
Standard Applicable	IEC 60947-5-1, 60947-5-4
Signaling Circuits Voltage	24 V dc $\pm$ 20%
Current	2 mA to 10 mA
Mounting	On left side of MCB/RCCB
Module width	9 mm
Local signaling	LED
Electrical Durability	20000 cycles conforming to IEC 60947-5-4
Market segment	Residential, small commercial
Environment Standard	IEC 60947-1 Annex S
IP Rating	IP 20
Pollution Degree	2 (IEC 60664-1)
Over-voltage Category	3
Tropicalization	2 (IEC 60947-5-1)
Relative humidity	93% (40 °C) according to IEC 60068-2
Operating temperature	-25 °C to 70 °C
Storage Temperature	-40 °C to 85 °C



## AUX CONTACTOR

Ax & A/M are the feedbacks sent to STADx Bridge (They are inputs for the latter). They tell whether contactor is ON or OFF and if it is ON, then whether it has been made on via 24 V dc (command from software) or 230 V ac (commanded manually).

C is the 24 V dc digital command sent to Aux contactor via STADx Bridge. It is the output for STADx Bridge and input for contactor auxiliary.

The auxiliary receives its 24 V dc operating power supply from STADx Bridge.

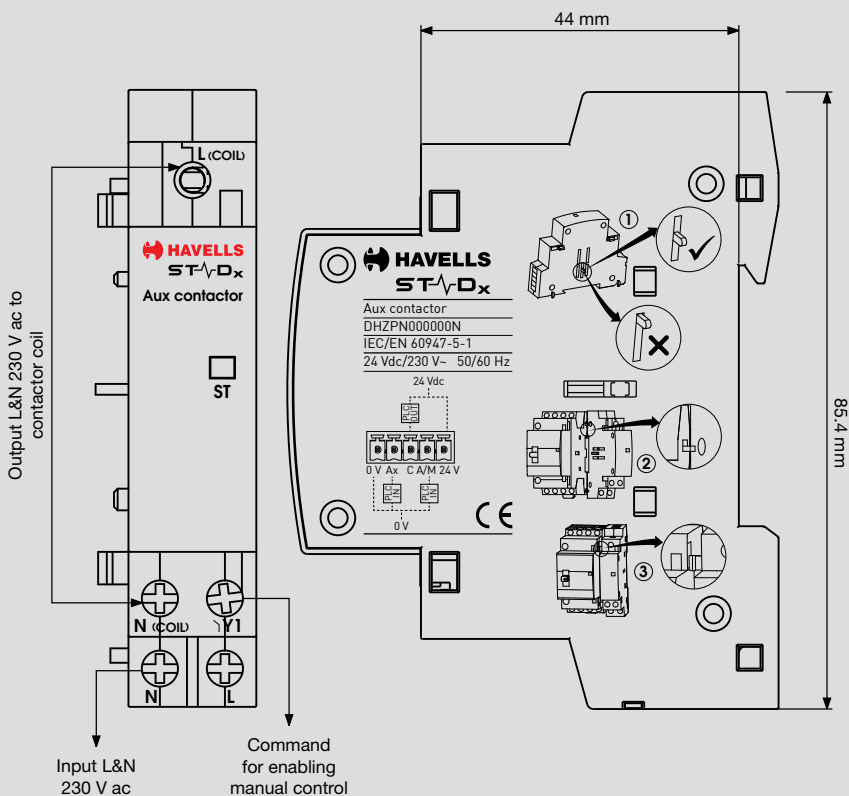
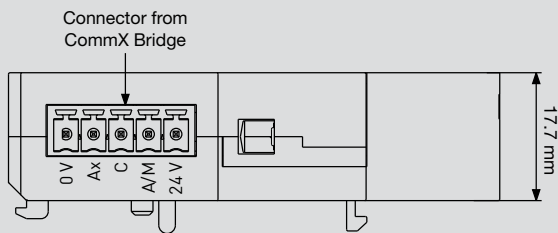

### Circuit Diagram

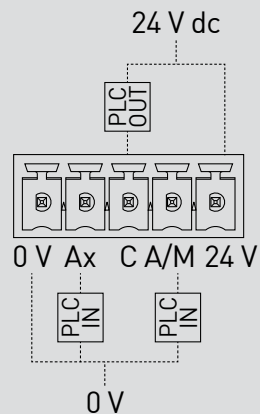

## Technical Specifications

Product Type	Control and Indication Auxiliary
Signaling Circuits Voltage	24 V dc $\pm$ 20%
Current	2 mA to 100 mA
Control Circuit Voltage	24 V dc or 230 V ac, both maintained for $\geq$ 200 ms
Mounting type	On the right side of modular contactor
Module width	18 mm
Electrical Durability	50,000 cycles conforming to IEC 60947-5-1
Connections in terminals	For tunnel type terminals : Flexible : 2 x 2.5 sq. mm, Rigid : 2 x 1.5 sq. mm
Wire stripping length	10 mm
Tightening torque	1 Nm
Product Compatibility	STADx Bridge, 230 V ac / 240 V ac 50 Hz
Market segment	Residential, small commercial
Environment Standard	IEC 60947-1 Annex S
IP Rating	IP 20
Pollution Degree	3 (IEC 60439-1)
Tropicalization	2 (IEC 60947-5-1)
Relative humidity	93% (40 °C) according to IEC 60068-2
Operating temperature	-25 °C to 60 °C
Storage Temperature	-40 °C to 80 °C

## Dimensions

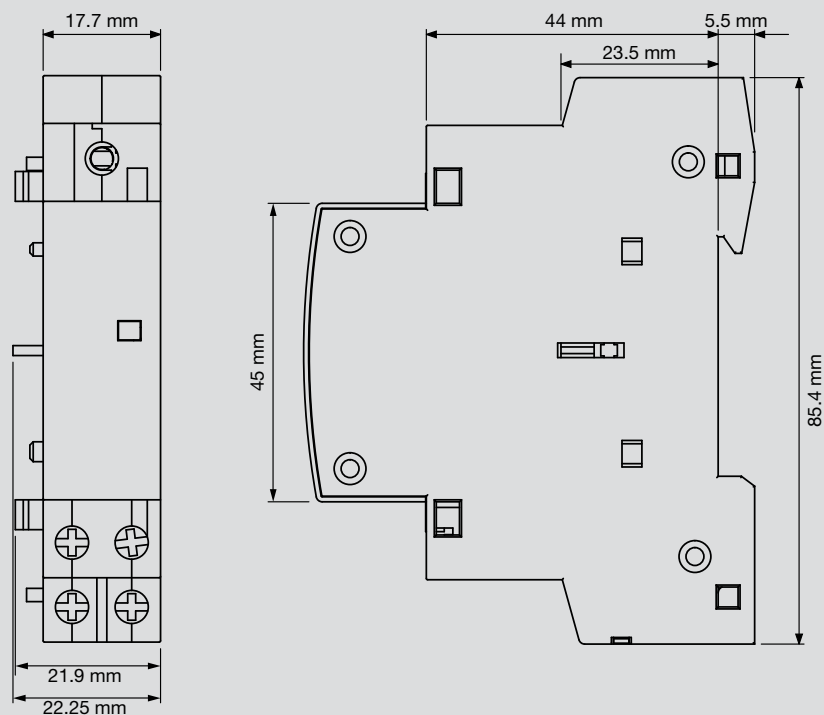

## RECLOSER MCB & RCCB

### Features:

- **Knob :** The knob of the recloser is mechanically attached to the Switchgear Device knob, and it turns and controls the switchgear knob through the motorised operation.
- **Padlock:** It is a mechanical arm which is used to block the movement of the knob to turn ON. This lock engages with the knob in OFF position to stop turning it to ON, and parallel gives a logic feedback to the controller through a sensing circuit so that controller should not provide any movement to the motor and gears to further protecting the mechanical movements from getting destructed.
- **Auto/Manual Switch:** This switch is used to select the operation mode of the device, whether DC supply controlled; or AC supply controlled / Manually controlled. Mode can be changed only after successful power restart.
- **Enable/Disable Switch:** This switch is used to enables the automatic reclosing operation when it is enabled, likewise disables the automatic reclosing operation when it is disabled. This switch is also used in case to reset recloser, when entered into permanent fault state.

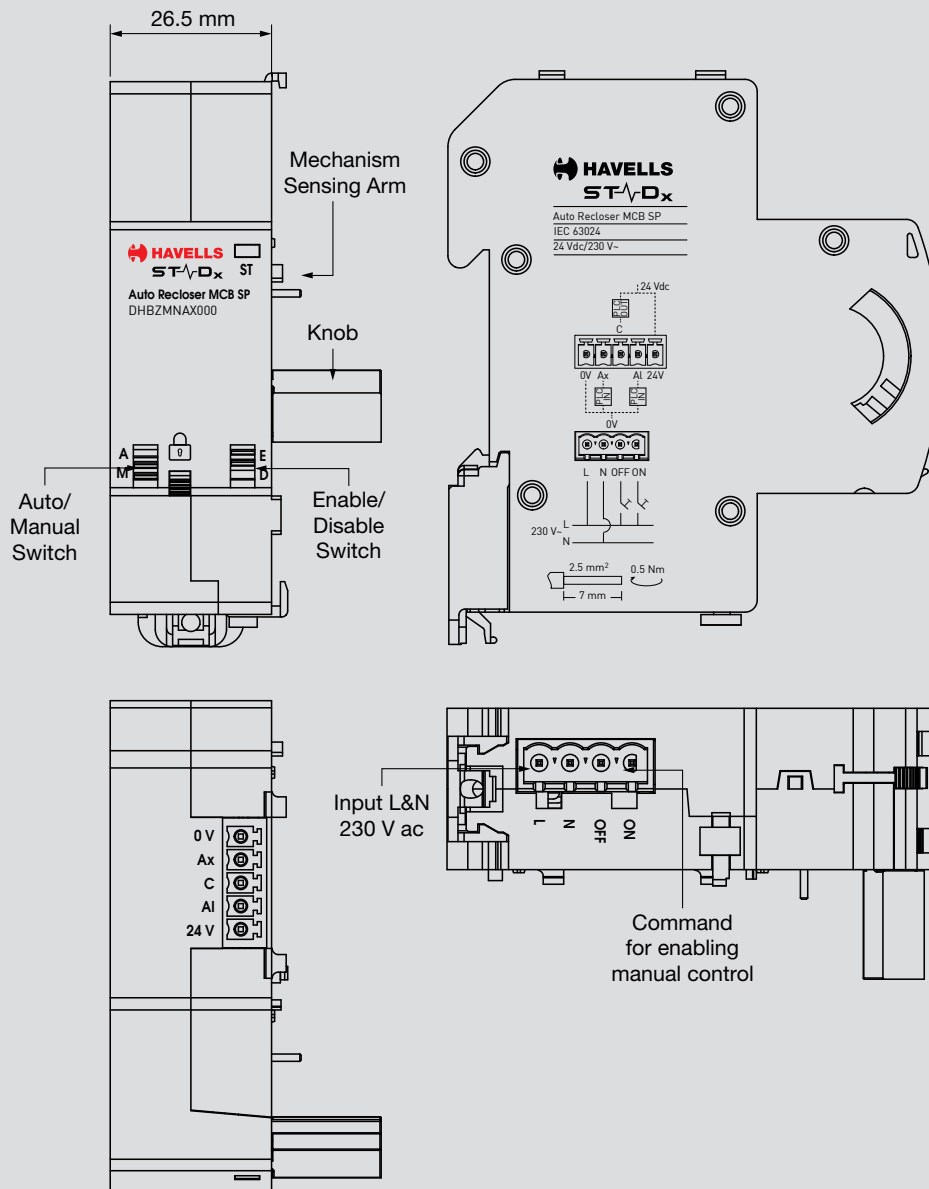

Technical Specifications		Recloser MCB	Recloser RCCB
Standard Conformity		IEC 63024	IEC 63024
Operating voltage		90 V-290 V	90 V-290 V
Operating frequency		50 Hz	50 Hz
Utilization Category		AC 31 A	AC 31 A
Pollution Degree		III	III
Operating Temperature		-25 °C to +75 °C	-25 °C to +75 °C
Storage Temperature		-40 °C to +80 °C	-40 °C to +80 °C
Electrical life		5000 cycles	5000 cycles
Mounting		DIN Rail	DIN Rail
Reclosing Delay Time		10 s, 20 s, 30 s, 40 s, 50 s	10 s, 20 s, 30 s, 40 s, 50 s
Mounting Type		On left side of compatible switchgear	On left side of compatible switchgear
Number of reclosing operations before getting blocked		5	5
Padlocking		Available	Available
Auto-Manual Mode		Available	Available
Enable-Disable Mode		Available	Available
LED Indications		MCB ON/OFF/Trip State	RCCB ON/OFF/Trip State
Control Via Local / Remote		Available	Available
Low Frequency Immunity	Voltage Dip	IEC 61008-1:2010 and IEC 61009-1:2010	IEC 61008-1:2010 and IEC 61009-1:2010
	Voltage Interruptions	IEC 61008-1:2010 and IEC 61009-1:2010	IEC 61008-1:2010 and IEC 61009-1:2010
	Voltage Unbalance	IEC 61000-4-5	IEC 61000-4-5
High Frequency Immunity	Conducted sine-wave form voltages or currents	IEC 61000-4-6 0.15 MHz to 80 MHz, z = 150 ohm, 3 V	IEC 61000-4-6 0.15 MHz to 80 MHz, z = 150 ohm, 3 V
	Fast transients (bursts) Common mode	IEC 61000-4-4 2 kV (peak), 5 ns/50 ns, 2.5 kHz	IEC 61000-4-4 2 kV (peak), 5 ns/50 ns, 2.5 kHz
	Surges	IEC 61000-4-5 1.2 μs/50 μs, 4 kV Common mode, 2 kV Differential mode	IEC 61000-4-5 1.2 μs/50 μs, 4 kV Common mode, 2 kV Differential mode
	Radiated electromagnetic field	IEC 61000-4-3 80 MHz to 1000 MHz, 10 V/m	IEC 61000-4-3 80 MHz to 1000 MHz, 10 V/m
	Conducted common mode disturbances in the frequency range lower than 150 kHz	IEC 61000-4-16 level 3rd	IEC 61000-4-16 level 3rd
Resistance to abnormal heat and to fire (Glow Wire)		IEC 60898-1:2015, 650 °C	IEC 61008-1:2010, 650 °C
Electrostatic discharges		IEC 61000-4-2, 8 kV: air, 6 kV: contact	IEC 61000-4-2, 8 kV: air, 6 kV: contact
Electromagnetic Emissions		As per CISPR 14-1	As per CISPR 14-1
Weight		< 500 g	< 500 g
Appearance		Compact	Compact



Ax & Al are the feedbacks sent to STADx Bridge (inputs for STADx Bridge). They tell whether Recloser MCB & RCCB is ON or OFF and if it is ON, then whether it has been made on via 24 V dc (command from software) or 230 V ac (commanded manually).

C is the 24 V dc digital command sent to Recloser MCB & RCCB via STADx Bridge. It is the output for STADx Bridge and input for recloser.

The recloser receives its 24 V dc operating power supply from STADx Bridge (auto mode) and 230 V ac from ON/OFF pin of recloser (manual mode). It need not be powered up separately.



Recloser RCCB



Recloser MCB

**Dimensions**

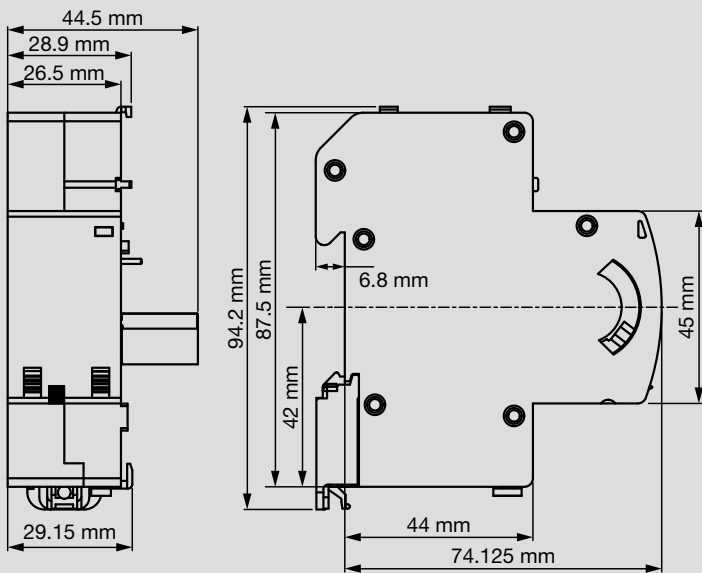

Recloser MCB SP

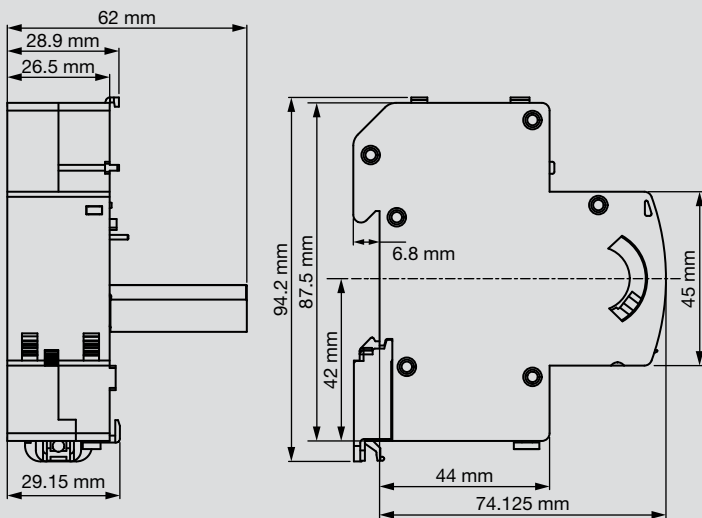

Recloser MCB MP

**Circuit Diagram**

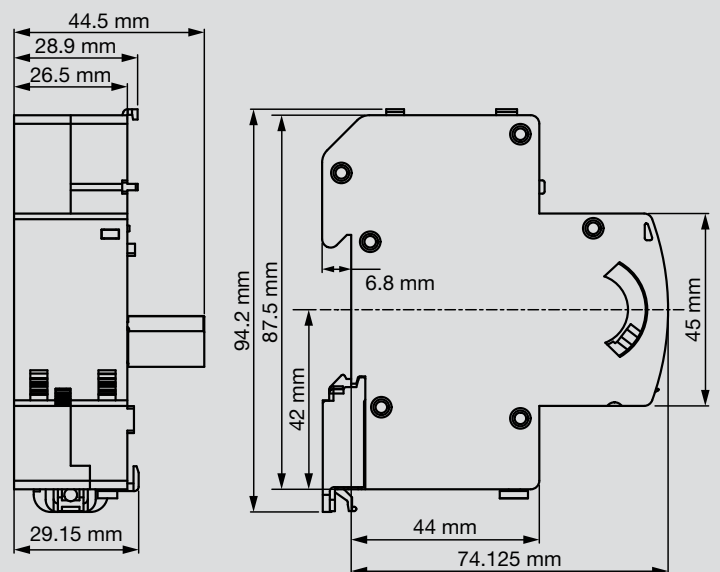
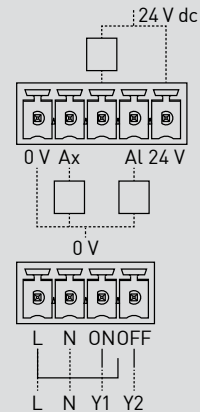

Recloser RCCB

## AUX MCCB

Ax & Al are the feedbacks sent to STADx Bridge (inputs for STADx Bridge). They tell whether MCCB is ON or OFF.

C is the 24 V dc digital command sent to Aux MCCB via STADx Bridge. It is the output for STADx Bridge and input for auto recloser.

The recloser receives its 24 V dc operating power supply from STADx Bridge. It need not be powered up separately.

Alternately, local controlling of MCCB via 230 V ac supply is also possible.



### Dimensions (in mm)

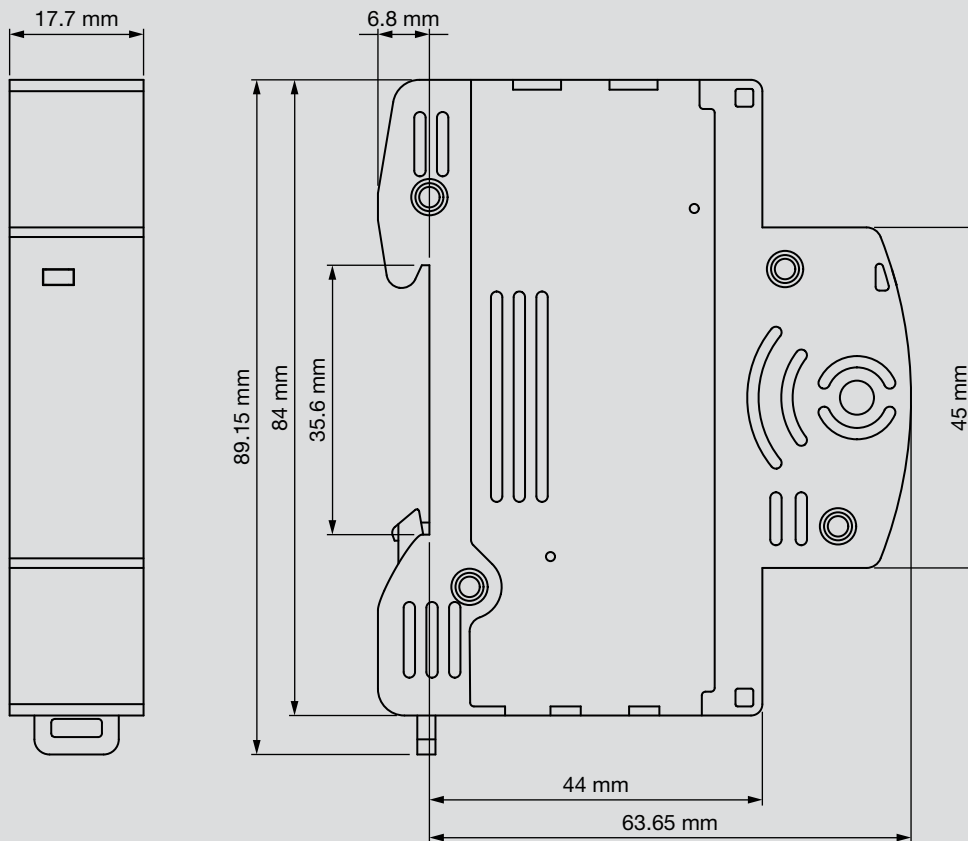

### Circuit Diagram

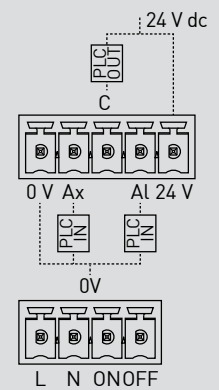

### Technical Specifications

Standard Conforming	IEC 60947-5-1
Operating Voltage	24 V dc
Utilization Category	AC 31 A
Indication	MCCB ON, OFF, TRIP
Pollution Degree	III
Operating Temperature	-25 °C to +75 °C
Mounting Position	DIN Rail Mountable via Snap Pusher
Dielectric Properties	IEC 60947-1
Resistance to Temperature Rise	IEC 60947-1
Control	MCCB ON/OFF
Electrical Endurance	50000 operations
Weight	< 300 g
Size	Compact
Cooling	Through Vents

# STADx DONGLE

Technical Specifications				
Parameter	STADx Bridge - Wireless	STADx Bridge - Wired	STADx Extend	STADx Transmuter
Voltage	5 V	5 V	5 V	5 V
Searching Mode Current	35 mA	-	35 mA	28 mA
Connecting Mode Current	35 mA	9 mA	35 mA	28 mA
Communication Mode Current	37 mA	27 mA	37 mA	30 mA
Temperature	-25 °C to +60 °C	-25 °C to +60 °C	-25 °C to +60 °C	-25 °C to +60 °C
Degree of protection	IP 20	IP 20	IP 20	IP 20
Fire withstand For live parts	30 s at 960 °C. IEC 60695-2-10 and IEC 60695-2-11	30 s at 960 °C. IEC 60695-2-10 and IEC 60695-2-11	30 s at 960 °C. IEC 60695-2-10 and IEC 60695-2-11	30 s at 960 °C. IEC 60695-2-10 and IEC 60695-2-11
Immunity to electrostatic discharge	-	Air: 8 kV	Air: 8 kV	-
Baud rate	19200 bps	19200 bps	19200 bps	19200 bps
length of connectivity	100 m (LOS)	Upto 1,000 m	100 m (LOS)	100 m/1000 m
Packet Size	120 bits	-	-	120 bits
RF output power	11 dBm	-	11 dBm	11 dBm
Sensitivity@1.2/100 kbits/s	-110 dBm/-97 dBm	-	-110 dBm/-97 dBm	-110 dBm/-97 dBm

## 1. STADx DONGLE WIRELESS:

### Features:

- Act as a Wireless Gateway to all the devices via RF communication.
- Connected to devices in mesh topology.
- USB type A connected to PC.
- Driver installation required in PC.

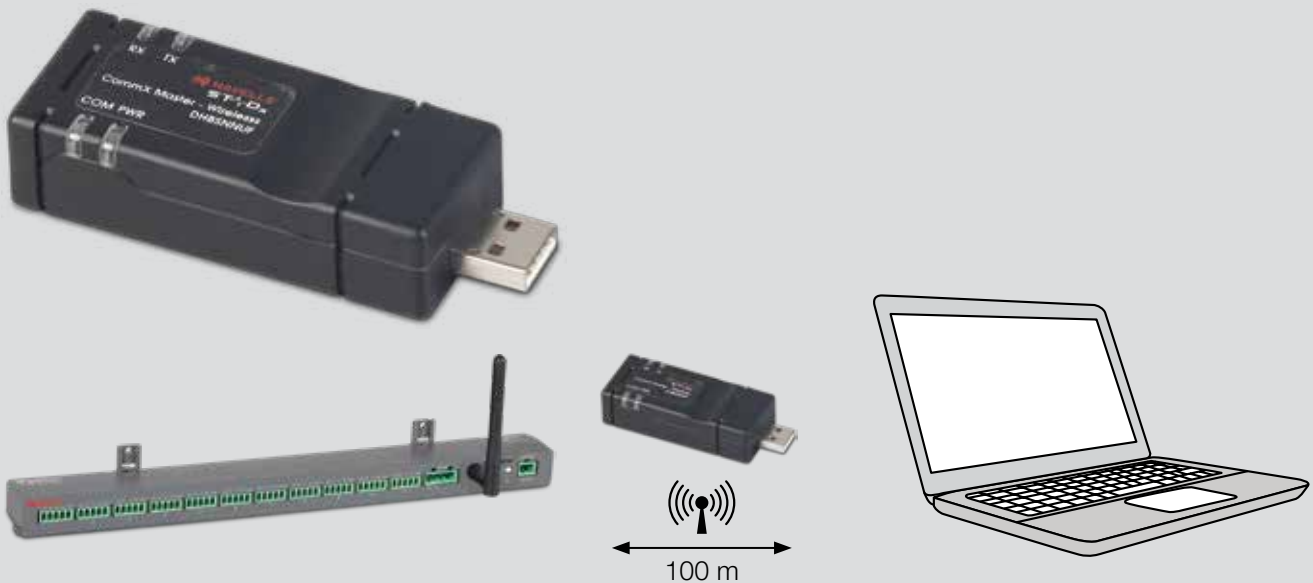

## 2. STADx DONGLE WIRED:

### Features:

- Converts USB Serial Data into RS485 serial data.
- Multiple nodes capable to both transmit and receive data.
- USB type A connected to PC.
- Driver installation required in PC.

Connect the CommX Wired with the STADx Bridge – Wired using the 4 pin connector.

4 pin connector

1	D-
2	D+
3	GND
4	Earth

Connect the CommX Wired with the PC via its USB port.

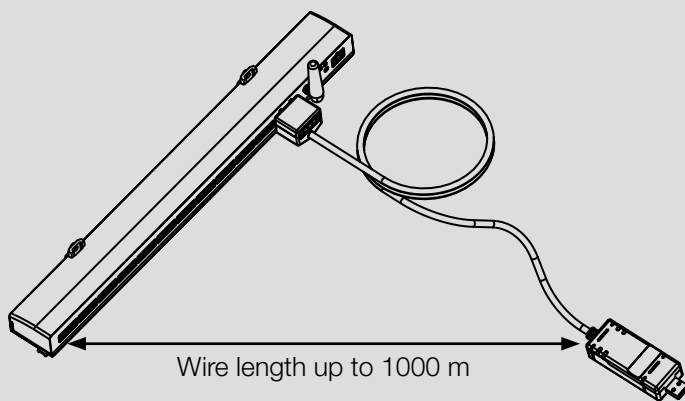

### 3. STADx EXTEND:

#### Features:

- Enhances the network wherever the connectivity is low in wireless network.
- Allows expansion using multiple access points without the need for a wired connection.
- USB type A connected to either PC or plugged into mobile chargers for powering it up for its operation.
- No drivers required for installation.

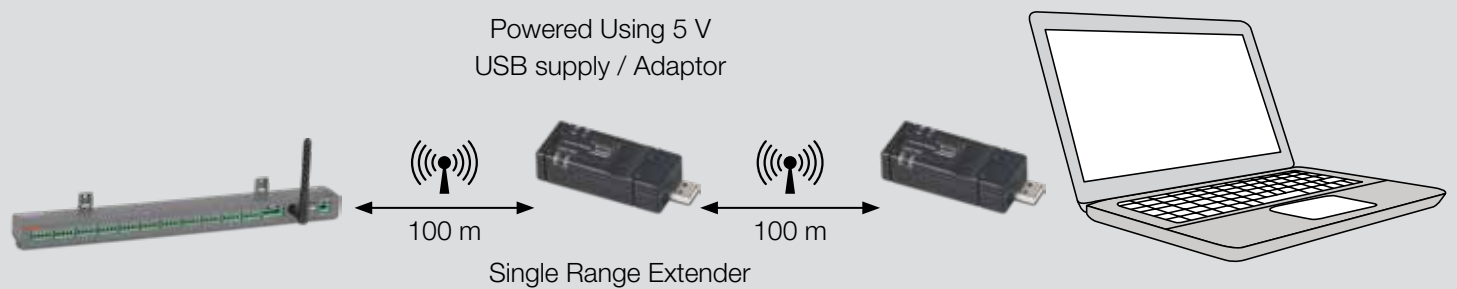

#### Dimensions (STADx Dongle Wireless)

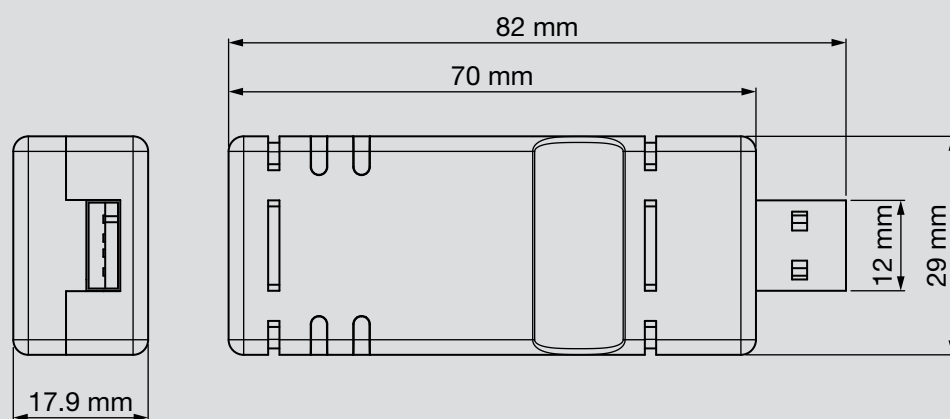

## 4. STADx TRANSMUTER:

### Features:

- Converts Data in Wireless Network to Wired Network, and vice-versa
- USB type A connected to either PC or plugged into mobile chargers for powering it up for its operation.

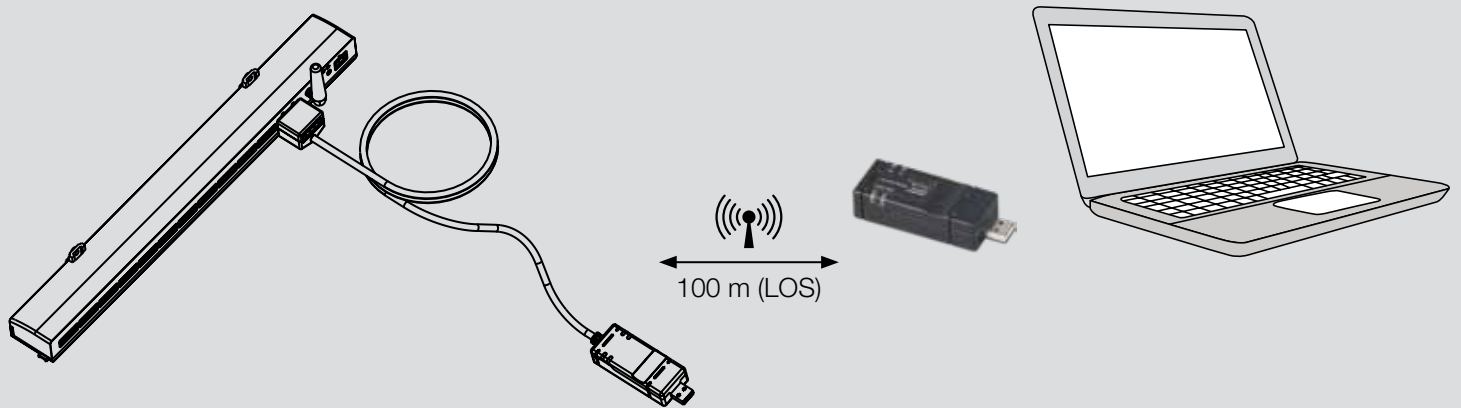

### Dimensions (STADx Dongle Wired)

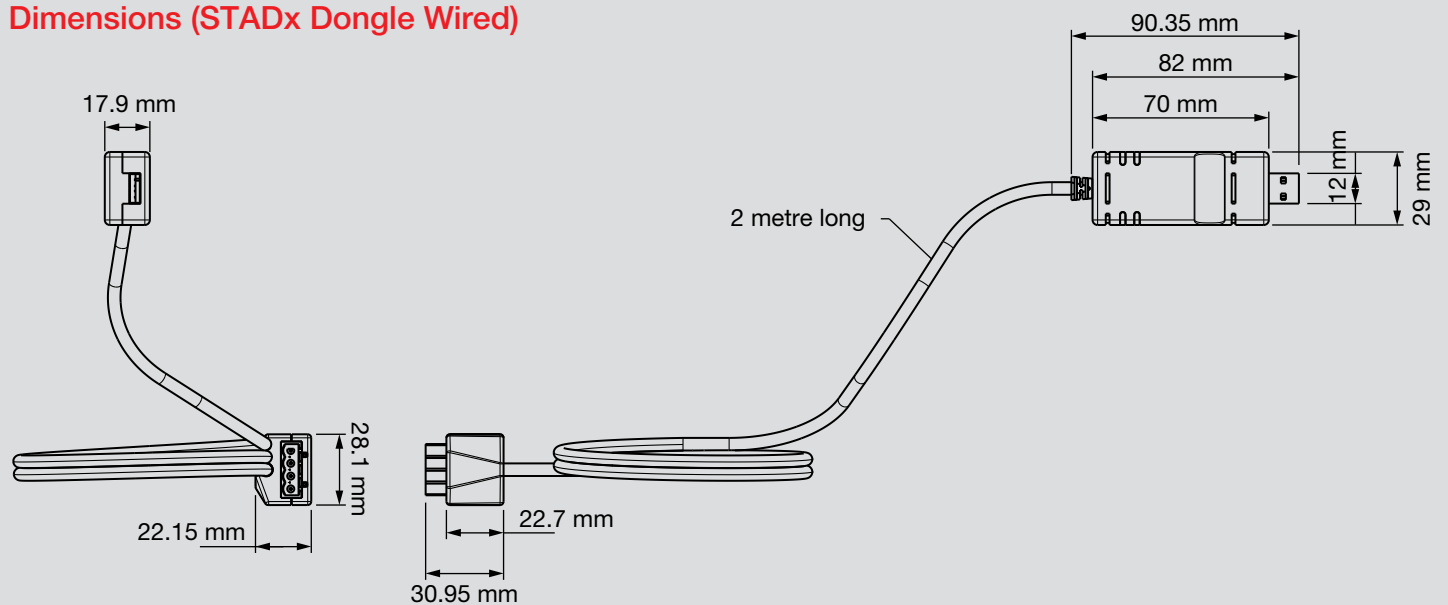

# STADx ENERGY METERS

## ENERGY METER - 1P 1M

### Product Description

Single phase multi-function meter is an ideal choice as a sub meter in residential, utility and industrial application. This compact unit measures and displays various important electrical parameters, and provide a RS485 communication port for remote reading and monitoring.

### Key Features:

- Measures kWh, Kvarh, KW, Kvar, KVA, PF, Hz, dmd, V, A, etc.
- Interactive LCD display with backlight for better user experience.
- Bi-directional measurement IMP & EXP
- Two pulse outputs
- 45 A direct connection
- Class 1 accuracy
- RS485 Modbus
- Compact size
- DIN rail mountable

Technical Specifications	
Operating Voltage	230 V
Base current	5 A
Max current	45 A
Frequency	50 Hz / 60 Hz
Power consumption	<2 W / 10 VA
AC withstand voltage	4 kV for 1 minute
Impulse voltage withstand	6 kV-1.2 uS waveform
Over current withstand	30 I <sub>max</sub> for 0.01 s
Data readout	LCD display with backlight
Active energy	Class 1 IEC 62053-21
Pulse outputs	2
Pulse output 1	Configurable
Pulse output 2	Non configurable
Max. Reading	99999.9 kWh
Operating temperature	-25 °C to +55 °C
Altitude	Up to 2000 m
Ingress protection	IP51 (indoor)
Degree of pollution	2
Operating humidity	0% to 95%
Mounting	DIN rail mounting
Dimensions	17.5 mm × 119 mm × 62 mm
Standard	IEC 62053-21
Warm up time	10 s
Mechanical Environment	M1
Electromagnetic environment	E2
Degree of pollution	2



## Communication

### Pulse output

The meter provides two pulse outputs. This generates pulses in proportion to the energy measured. Both pulse outputs are polarity dependent, requiring an external voltage source for correct operation. For this the voltage shall be 5 V dc-27 V dc and maximum input current shall be 27 mA DC.

- **Pulse output 1 :**

Pulse output 1 is configurable. The pulse output can be set to generate pulses to represent total / import / export kWh or kVarh.

The pulse constant can be set to generate 1 pulse per: 0.001(default) /0.01/0.1/kWh/kVarh. Pulse width: 200 ms / 100 ms / 60 ms

- **Pulse output 2:**

Pulse output 2 is non-configurable. It is fixed up with total kWh. The constant is 1000imp/kWh. Pulse width is 60 ms.

### RS485 output for Modbus RTU

The meter provides a RS485 port for remote communication. Modbus RTU is the protocol applied. For Modbus RTU, the following RS485 communication parameters can be configured from the Set-up menu.

Baud rate: 1200, 2400, 4800, 9600

Parity: NONE/EVEN/ODD

Stop bits: 1 or 2

Modbus Address: 1 to 247

## Wiring Diagram

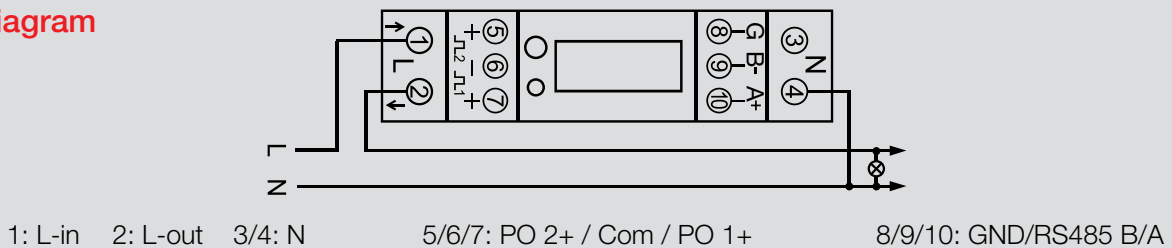

## Dimensions

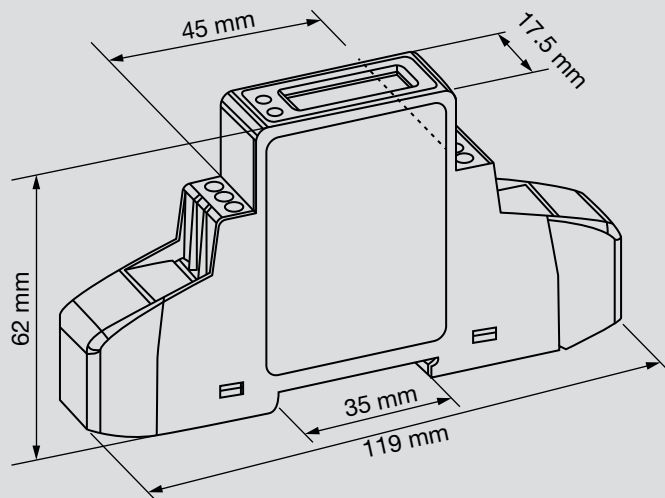

# ENERGY METER - 1P 2M

## Product Description

Single phase multi-function energy meter (2 module) measures and displays various important electrical parameters and provide a communication port for remote reading and monitoring. Bi-directional energy measurement makes the unit a good choice for solar PV energy metering.

## Key Features:

- Measures kWh, Kvarh, KW, Kvar, KVA, PF, Hz, V, A, etc.
- Interactive LCD display with backlight for better user experience.
- Bi-directional measurement IMP & EXP
- Dual tariff metering
- Two pulse outputs
- 100 A direct connection
- Class 1 accuracy
- RS485 Modbus
- DIN rail mountable

Technical Specifications	
Operating Voltage	230 V
Base current	10 A
Max current	100 A
Frequency	50 Hz / 60 Hz
Power consumption	<2 W / 10 VA
AC withstand voltage	4 kV for 1 minute
Impulse voltage withstand	6 kV-1.2 uS waveform
Over current withstand	30 I <sub>max</sub> for 0.01 s
Data readout	LCD display with backlight
Active energy	Class 1 IEC 62053-21
Pulse outputs	2
Pulse output 1	Configurable
Pulse output 2	Non configurable
Max. Reading	999999.9 kWh
Operating temperature	-25 °C to +55 °C
Altitude	Up to 2500 m
Ingress protection	IP51 (indoor)
Degree of pollution	2
Operating humidity	0% to 95%
Mounting	DIN rail mounting
Dimensions	36 mm × 99 mm × 63 mm
Standard	IEC 62053-21
Warm up time	10 s
Mechanical Environment	M1
Installation category	CAT III
Electromagnetic environment	E2
Degree of pollution	2



## Communication

### Pulse output

The meter provides two pulse outputs. This generates pulses in proportion to the energy measured. Both pulse outputs are polarity dependent, requiring an external voltage source for correct operation. For this the voltage shall be 5 V dc-27 V dc and maximum input current shall be 27 mA dc.

- **Pulse output1:**

Pulse output 1 is configurable. The pulse output can be set to generate pulses to represent total / import/export kWh or kVarh.

The pulse constant can be set to generate 1 pulse per: 0.001(default) /0.01/0.1/kWh/kVarh.

Pulse width: 200 ms/100 ms/60 ms

- **Pulse output 2:**

Pulse output 2 is non-configurable. It is fixed up with total kWh. The constant is 1000 imp/kWh.

Pulse width is 60 ms.

### RS485 output for Modbus RTU

The meter provides a RS485 port for remote communication. Modbus RTU is the protocol applied. For Modbus RTU, the following RS485 communication parameters can be configured from the Set-up menu.

Baud rate: 1200, 2400, 4800, 9600

Parity: NONE/EVEN/ODD

Stop bits: 1 or 2

Modbus Address: 1 to 247

## Wiring Diagram

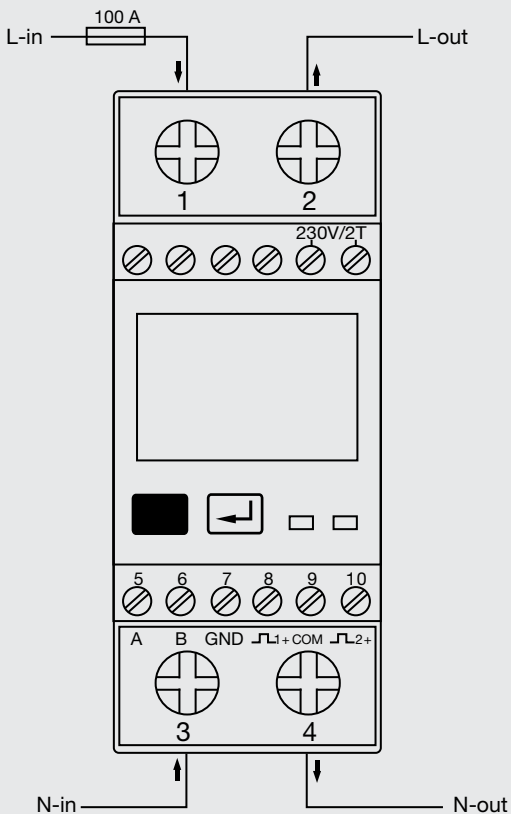

## Dimensions

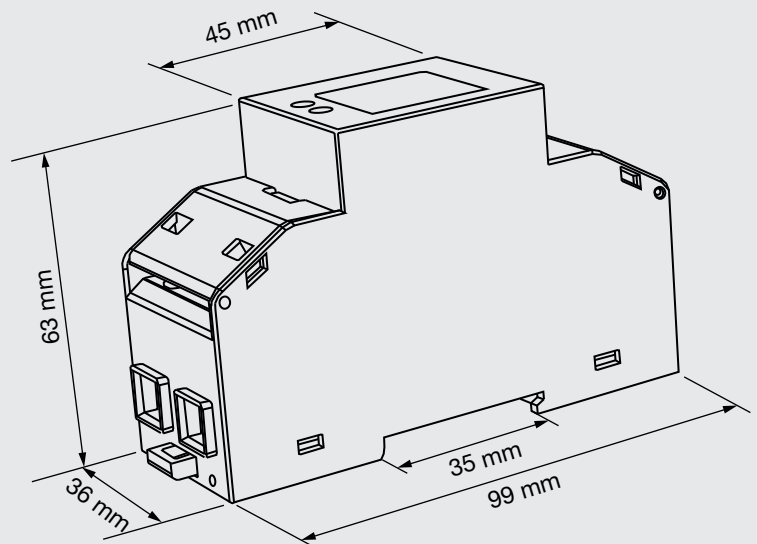

## ENERGY METER - 3P

Three phase multi-function energy meter measures and displays the characteristics of single phase two wires (1P 2 W), three phase three wires (3P 3 W) and three phase four wires (3P 4 W) supplies, including voltage, frequency, current, power, active and reactive energy, imported or exported. Saving the cost to install external CT. Built in interfaces provide pulse and RS485 Modbus RTU outputs. The unit can also measure maximum demand current and power over preset periods of upto 60 minutes. Dual tariff function makes tenant metering easy for dual source applications to differentiate between the mains and backup supply.

### Features:

- 100 A direct load
- Extensive real time measurement ( kWh, kVarh, W, kVar, kVA, PF, Hz, V, A, etc) giving consumers greater detail of their energy usage.
- Interactive LCD display with backlight for better user experience.
- Work with 3P 4 W, 3P 3 W and 1P 2 W.
- Dual tariff metering
- Import / Export option enables monitoring of bi-directional power flow
- Communication: Pulse output or RS485 port
- Class 1 accuracy
- Easy to install and operate
- DIN rail mountable

Technical Specifications	
Operating Voltage	3* 230 V ac / 400 V ac
Base current	10 A
Max current	100 A
Frequency	50 Hz / 60 Hz
Power consumption	<2 W / 10 VA
AC withstand voltage	4 kV for 1 minute
Impulse voltage withstand	6 kV-1.2 uS waveform
Over current withstand	30 I <sub>max</sub> for 0.01 s
Instantaneous power	0 to 99999 W
Reactive power	30 I <sub>max</sub> for 0.01 s
Data readout	LCD display with backlight
Active energy	Class 1 IEC 62053-21
Pulse outputs	2
Pulse output 1	Configurable
Pulse output 2	Non configurable
Max. Reading	999999. 99kWh
Operating temperature	-25 °C to +55 °C
Storage temperature	-40 °C to +70 °C
Altitude	Up to 2000 m
Ingress protection	IP51 (indoor)
Degree of pollution	2
Relative humidity	0% to 90%
Warm up time	1 minute
Vibration	10 Hz to 50 Hz, IEC 60068-2-6, 2 g
Mounting	DIN rail mounting





Technical Specifications	
Dimensions	72 mm × 100 mm × 66 mm
Standard	IEC 62053-21
Mechanical Environment	M1
Installation category	CAT III
Electromagnetic environment	E2
Degree of pollution	2

## Communication

### Pulse output

The meter provides two pulse outputs that indicate real time energy measurement. This generates pulses in proportion to the energy measured. The pulse output can be set to generate pulses to represent total / import/export kWh or kVarh.

- **Pulse output 1:**

Pulse output 1 is configurable. The pulse output can be set from the set up menu to generate pulses to represent total / import/export kWh or kVarh. The default pulse width is 100 ms.

The pulse constant can be set to generate 1 pulse per:

dFt = 2.5 Wh/VArh

0.01 = 10 Wh/VArh

0.1 = 100 Wh/VArh

1 = 1 kWh/kVArh

10 = 10 kWh/kVArh

100 = 100 kWh/kVArh

- **Pulse output 2:**

Pulse output 2 is non-configurable. The constant of pulse output 2 for active energy is 400imp/kWh. Pulse width is 100 ms.

### RS485 output for Modbus RTU

The meter uses a RS485 port with Modbus RTU protocol for remote monitoring and controlling. An RS485 output allows remote monitoring from another computer. The parameters can be configured from the Set-up menu.

Bus type	RS485
Protocol	Modbus RTU
Baud rate	2400, 4800, 9600, 19200, 38400
Modbus Address	001 to 247
Parity	NONE(default)//EVEN/ODD
Data bit	8
Stop bits	1 or 2

## Dimensions

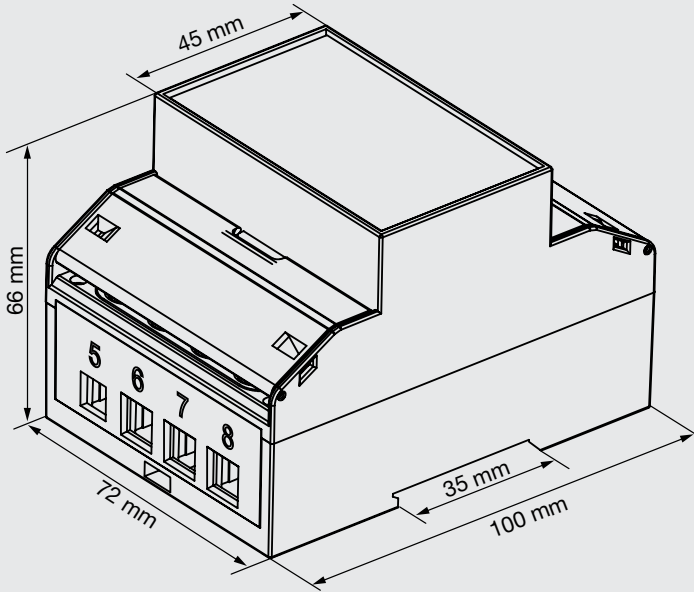

## Wiring Diagram: Three Phase Three Wires

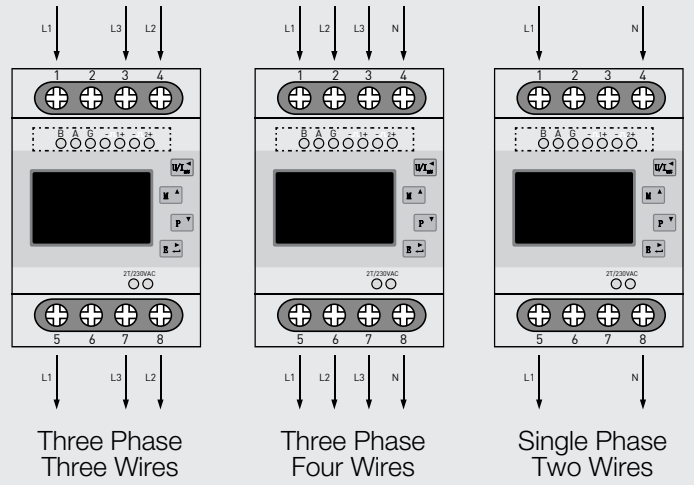

## Wire Harness

### Dimensions (in mm)

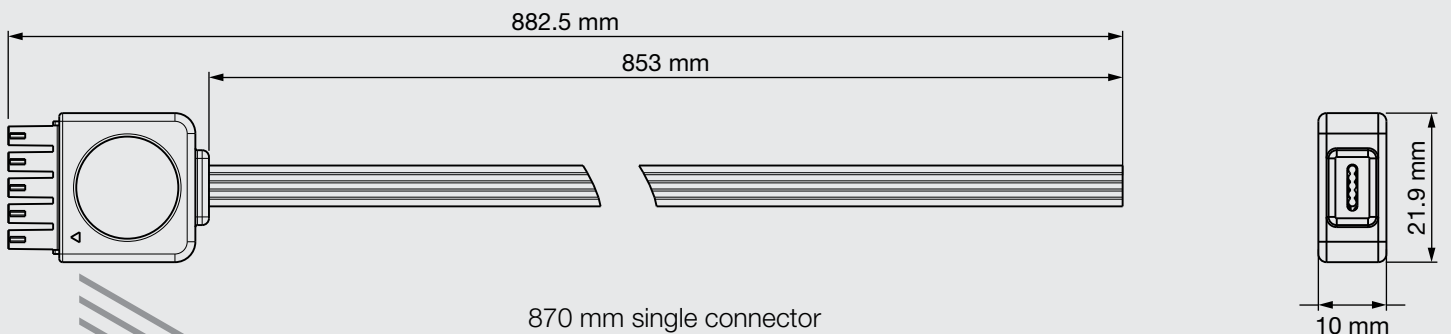
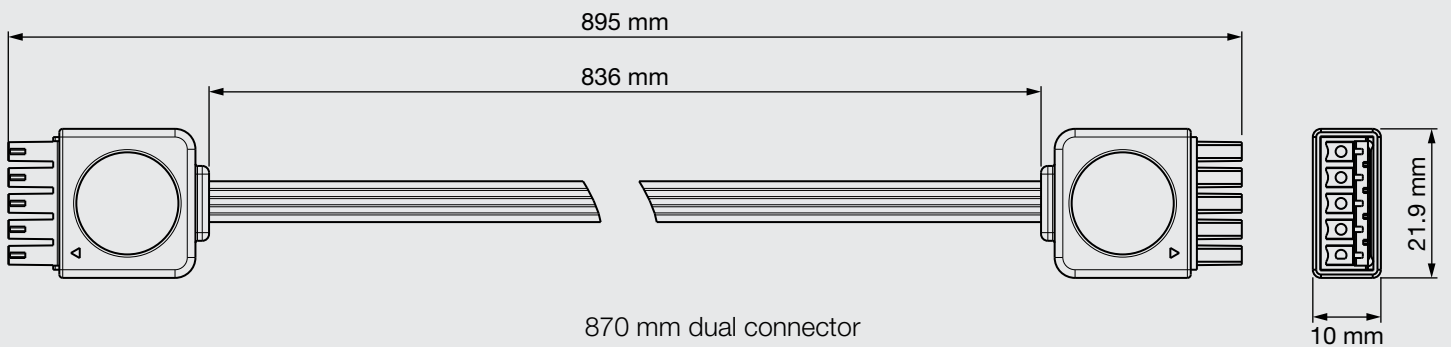
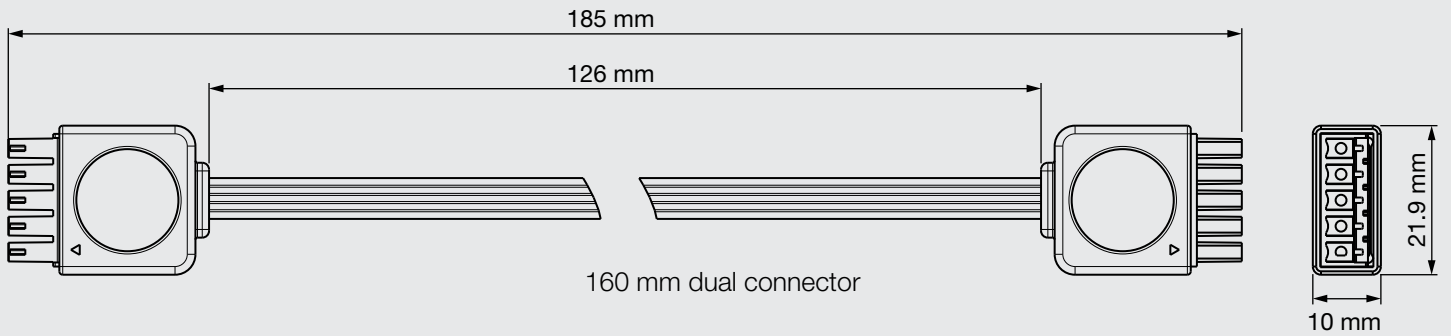



## STADx BAR

Technical Specifications	
Max Operated Voltage	440 V ac
Current rating	80 A
Rated insulation voltage	500 V ac
Operating Frequency	50 Hz/60 Hz
Rated impulse withstand voltage	6 kV
Degree of protection	IP20
Number of outgoing terminals	2 rows of terminals: 18 connection points for phases (L1, L2, L3) & 18 connection points for neutral
Cable size incomer	One cable per connection point: - flexible from 6 mm <sup>2</sup> to 25 mm <sup>2</sup> - rigid from 10 mm <sup>2</sup> to 35 mm <sup>2</sup>
Cable size outgoing	A single cable per connection point: flexible (without ferrule) or rigid from 1 mm <sup>2</sup> to 6 mm <sup>2</sup>
Mounting	Bracket Mounting
Dimensions	60.8 mm × 456 mm × 37.8 mm
Standard Compliance	IEC 60947-7-1

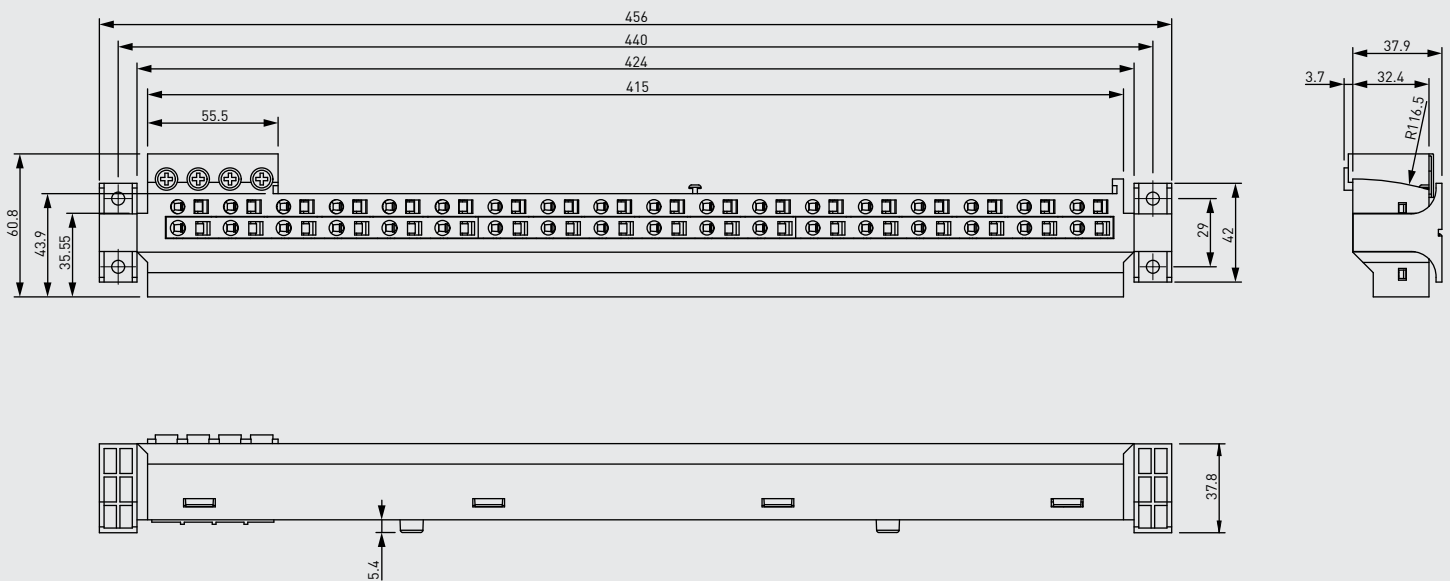
### Dimensions (in mm)



# ARC FAULT DETECTION DEVICE

Technical Specification		
	AFDD with MCB	AFDD with RCBO
		
Standard Compliance	IEC 62606 & IEC/EN 60898-1	IEC 62606 & IEC/EN 60898-1 & IEC 61009-1
No of Poles	1P+N	1P+N
Module Type	2 Module	4 Module
Rated Current In (A)	16 A, 32 A & 40 A	16 A, 32 A & 40 A
Rated Residual Operating Current (IΔn)	-	30 mA, 100 mA
Operating Characteristics in case of residual currents	-	A Type
Rated Voltage Ue (V)	230 V ac	230 V ac
Insulation voltage Ui (V)	500 V ac	500 V ac
Min Threshold for protection against overvoltage (V)	270 V ± 5%	270 V ± 5%
Rated Frequency (Hz)	50 Hz	50 Hz
Rated Breaking Capacity	10 kA	10 kA
Ambient Temperature (°C)	-5 °C to 40 °C	-5 °C to 40 °C
Storage Temperature (°C)	-20 °C to 60 °C	-20 °C to 60 °C
Terminal Supply Side	Bottom/Top	Bottom/Top*
Mounting Type	Clip on DIN Rail (35 mm x 7.5 mm)	Clip on DIN Rail (35 mm x 7.5 mm)
Electrical Endurance	4000	4000
Mechanical Endurance	10000	10000
Tightening Torque	2 Nm	2 Nm (Bottom) / 1.2 Nm (Top)
Ingress Protection	IP 20	IP 20
Max Power Loss	7 W	5 W
Conductor Cross-Section (Solid & Stranded)	0.75 mm <sup>2</sup> - 35 mm <sup>2</sup>	0.75 mm <sup>2</sup> - 16 mm <sup>2</sup> (Top) 0.75 mm <sup>2</sup> - 35 mm <sup>2</sup> (Bottom)
Tripping Characteristic Curve	C Curve	C Curve
Energy Limit Class	3	3
Indications	Mechanical indication (ON-Red, OFF-Green), LED Indication (ON-Red, OFF-blank)	LED Indication (ON-Red, OFF-blank)

\* ADD ON AFDD SPN have bottom terminal supply side.



**Dimensions (in mm)**

**AFDD with MCB**

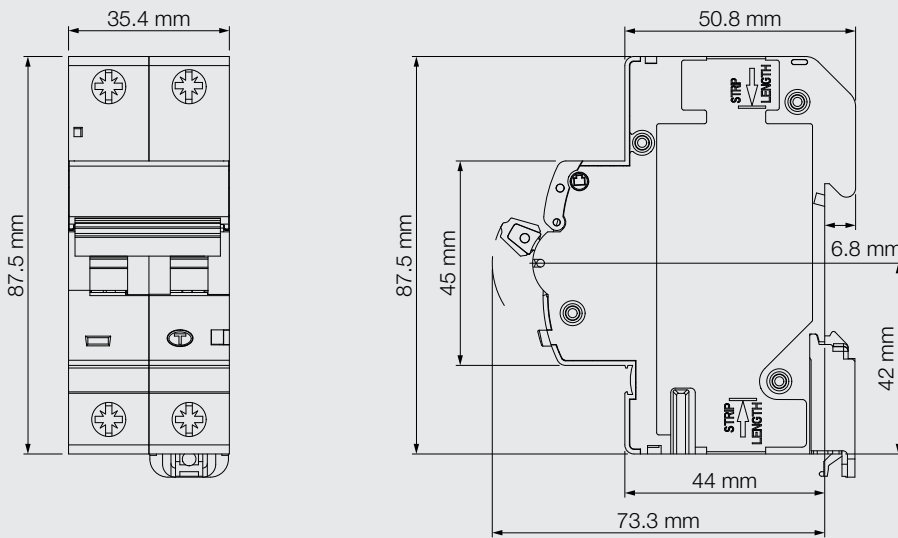

**AFDD with RCBO**

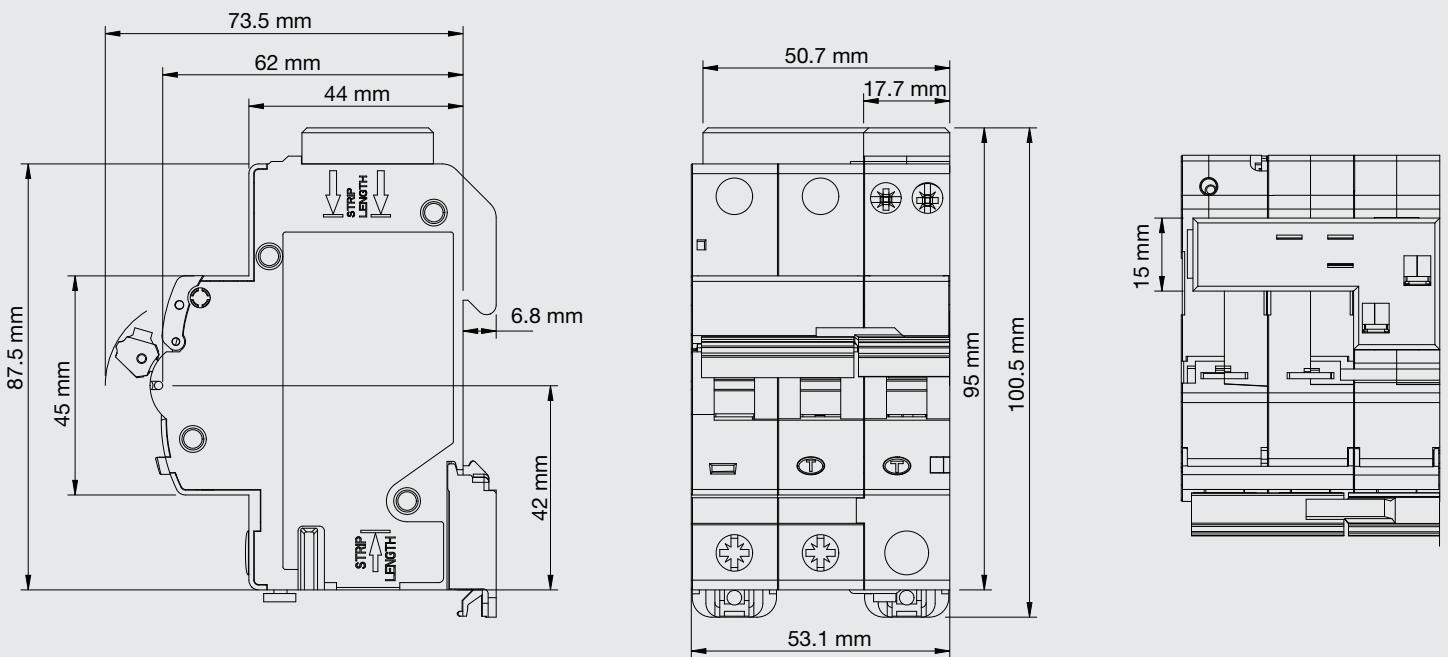

# MINIATURE CIRCUIT BREAKER

A circuit breaker is an electro mechanical device designed to protect an electrical circuit from damage caused by overload or short circuit. Its basic function is to detect a fault condition and, by interrupting continuity, to immediately discontinue electrical flow. Unlike a fuse, which operates once and then has to be replaced, a circuit breaker can be reset (either manually or automatically) to resume and normal operation.

## Construction

Miniature Circuit Breakers have precisely formed moulded case & cover of flame retardant high strength thermoplastic material having high melting point, low water absorption, high dielectric strength and temperature capacity. The Switching Mechanism is independent, manual and trip free, i.e., The breaker trips internally even if the operating knob is held in ON position.

The Contact Mechanism, comprises of fixed & moving contacts specially designed for reliability, long life and anti-weld properties. The Arc Extinguishing Device comprises of 13 plates arc chute. The arc under the influence of the magnetic field and arc guide is moved into the arc chute where it is rapidly split and quenched. The tripping mechanism is Thermal Magnetic Type.

## Thermal Operation

The thermal operation provides protection from moderate overloads. Under overload condition, a thermometallic element (bimetallic strip) deflects until it operates a latching mechanism allowing the main contacts to open.

## Magnetic Operation

In magnetic operation, large overloads or short circuit current actuates a solenoid causing a plunger to strike the latching mechanism rapidly opening the main contacts.

## Internal View

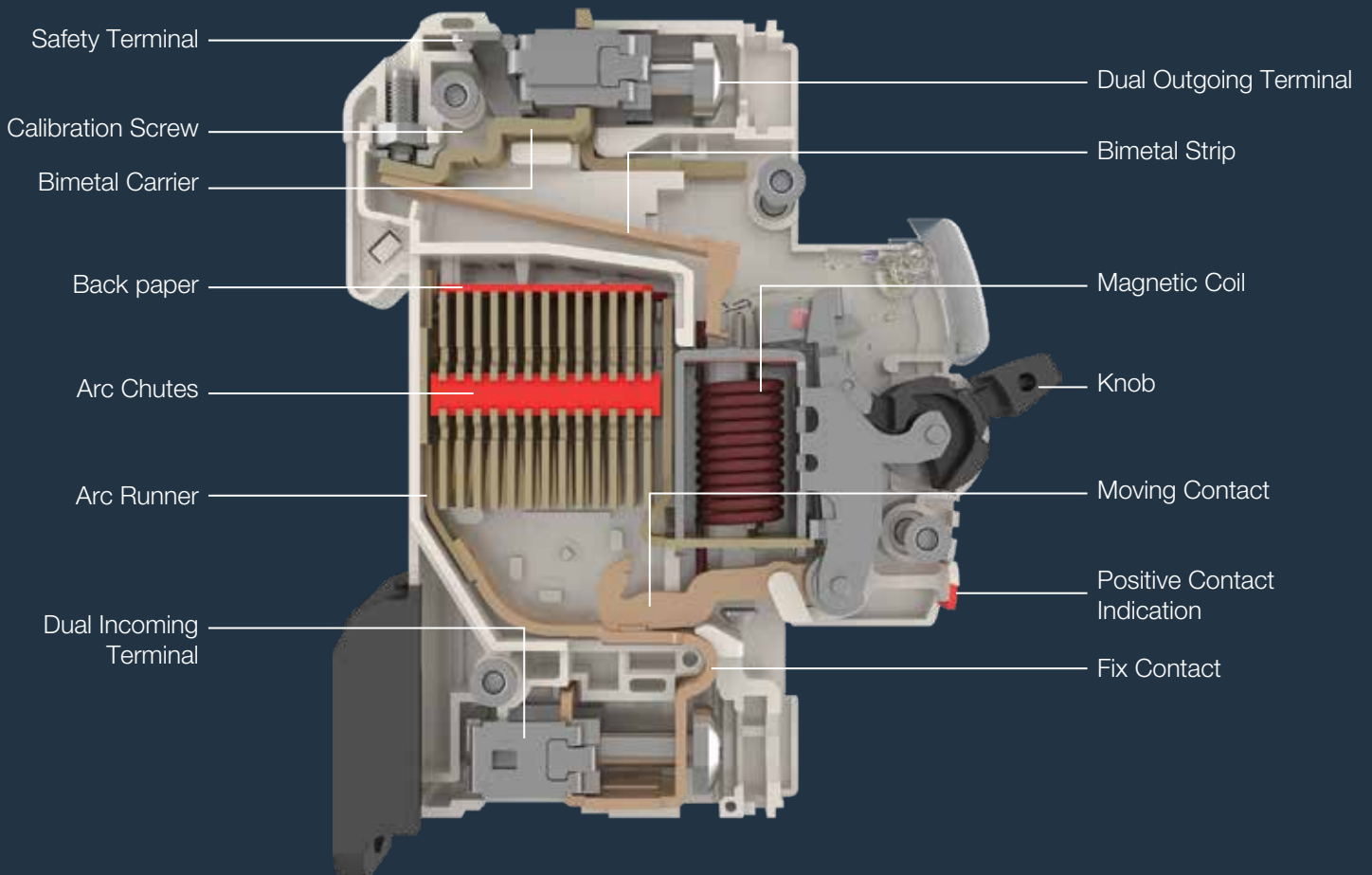

### Technical Specification

Reference Standard	IS/IEC 60898-1 ; IEC 60947-2
Type / Series	C & D Curve
No. of Poles	1P, 1P+N, 2P, 3P, 3P+N, 4P
Rated Current (In)	0.5 A, 1 A, 2 A, 3 A, 4 A, 5 A, 6 A, 10 A, 16 A, 20 A, 25 A, 32 A, 40 A, 50 A, 63 A
Rated Voltage (Ue)	240 V ac/415 V ac
Rated Frequency	50 Hz
Rated Short Circuit Breaking Capacity	10 kA - C Curve, 10 kA - D Curve ≤32 A, 4.5 kA - D Curve >32 A
Magnetic Release Setting	(5-10) In - C Curve, (10-20) In - D Curve
Rated Insulation Voltage (Ui)	690 V
Rated Impulse Voltage (Uimp)	4 kV
Dielectric Strength	2.5 kV
Electrical / Mechanical Endurance (no. of operations) minimum	10000/20000
Operating Temperature	-5 °C to +55 °C
Humidity	95% RH
Energy Limit Class	3
Terminal Capacity (max)	35 mm <sup>2</sup>
Tightening Torque	2 N-m
Vibration	3 g
Shock Resistance	40 mm free fall
Protection Class	IP 20
Positive Contact Indication	Yes, Through Flag Indication (Red-ON, Green-OFF)
Net Weight / Pole in kg	125 g
Dimensions (H x D x W) / Pole in mm	87.5 mm x 62 mm x 17.7 mm
Mounting	Clip on DIN Rail (35 mm x 7.5 mm)
Installation Position	Vertical / Horizontal
Case & Cover	Moulded, flame-retardant thermoplastic material
Bus bar Connections Top Side	Pin Type
Bus bar Connections Bottom Side	Pin / Fork Type
Auxiliary Contacts	Yes
Shunt Trip	Yes

### Dimensions (in mm)

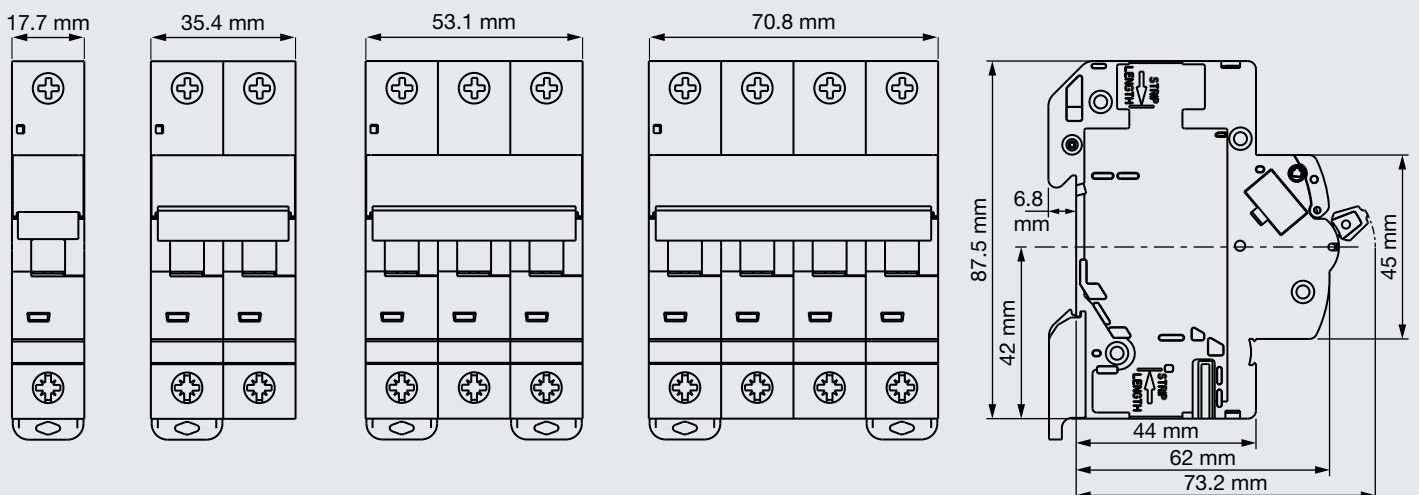

## Characteristics According To IS/IEC 60898-1

Miniature Circuit Breakers (MCB) are intended for the protection of wiring installations against both overloads and short-circuits in domestic or commercial wiring installations where operation is possible by uninstructed people

## Characteristics Curves

As per	Thermal Tripping			Magnetic Tripping		
	No tripping	Tripping	Time	Hold	Trip	Time
IS / IEC 60898-1	Current	Current	Limits	Current	Current	Limits
	$I_1$	$I_2$	t	$I_4$	$I_5$	t
C Curve	$1.13 \times I_n$		1h for $\leq 63$ A, 2h for $> 63$ A	$5 \times I_n$		$\geq 0.1$ s
		$1.45 \times I_n$	2h for $\leq 63$ A, 2h for $> 63$ A		$10 \times I_n$	$< 0.1$ s
D Curve	$1.13 \times I_n$		$\geq 1$ h	$10 \times I_n$		$\geq 0.1$ s
		$1.45 \times I_n$	$< 1$ h		$20 \times I_n$	$< 0.1$ s
$I_3 = 2.55 \times I_n$	$1 \text{ s} < t < 60 \text{ s}$ for $I_n$ ( $I_n \leq 32 \text{ A}$ ) $1 \text{ s} < t < 120 \text{ s}$ for $I_n$ ( $I_n > 32 \text{ A}$ )					

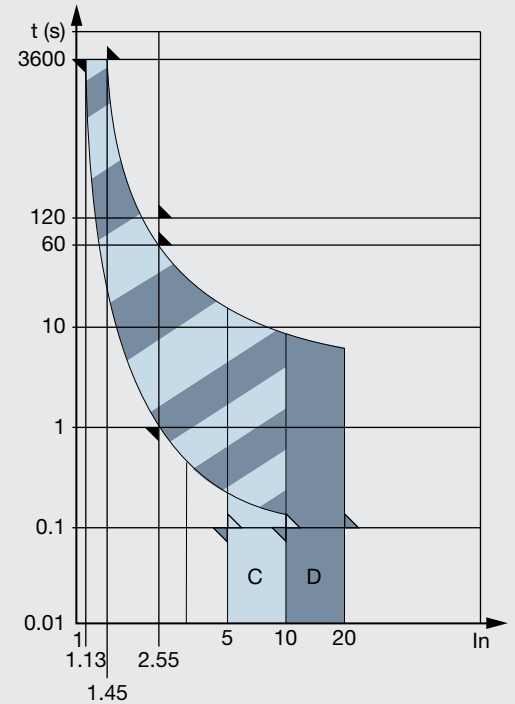

## Tripping Characteristics

Based on the Tripping Characteristics, MCBs are available in 'C' and 'D' curve to suit different types of applications.

## Thermal Tripping

The Tripping is initiated by a bimetal strip in case of overload. The standard defines the range of tripping for specific overload values. Reference ambient temperature is 30 °C.

## Magnetic Tripping

An electromagnet with plunger ensures instantaneous tripping in the event of short-circuit.

'C' Curve: for protection of electrical circuits with equipment that causes surge current (inductive loads and motor circuits). Short circuit release is set to (5-10)  $I_n$  'D' Curve: for protection of electrical circuits which causes high inrush current, typically 12-15 times the thermal rated current (transformers, X-ray machines etc.) Short circuit release is set to (10-20)  $I_n$

## Time current characteristics for 80 A-125 A

Rating - 80 A to 125 A Ref. calibration Temp. : 30 °C  
Ref. standard: IEC 60947-2

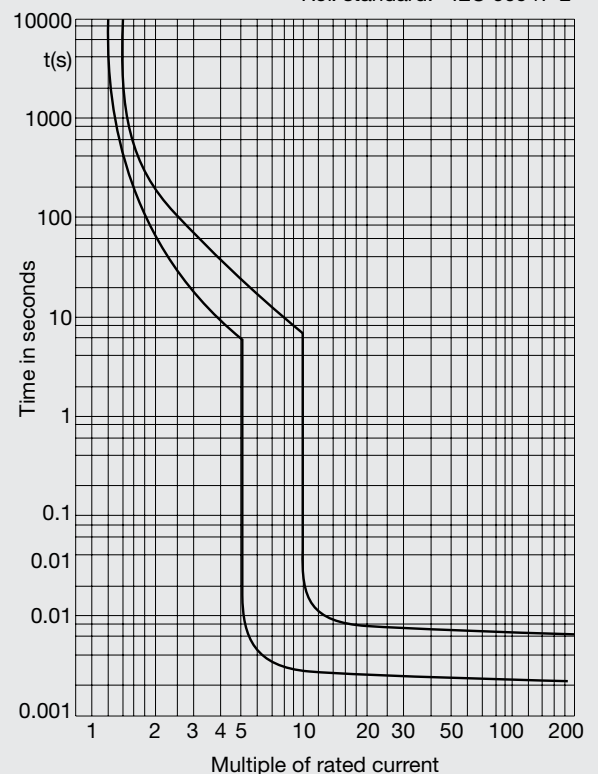

## Current Limiting Design

In a current limiting breaker, the tripping & arc control mechanism are so designed that under short circuit conditions, the contacts are physically separated and the electrodynamic forces set up by fault current, assist the extinction in less than half cycle.

The figure shows the current limiting effect of circuit breakers.

Fault Traces for Voltage & Current

- 0 = Point of fault initiation
- $t_x$  = Contact opening time (i.e., creation of arc)
- $t_1$  = Current / Voltage peak (i.e., current limitation)
- $t_2$  = Time to total extinction of arc (i.e., complete shutdown of fault current)

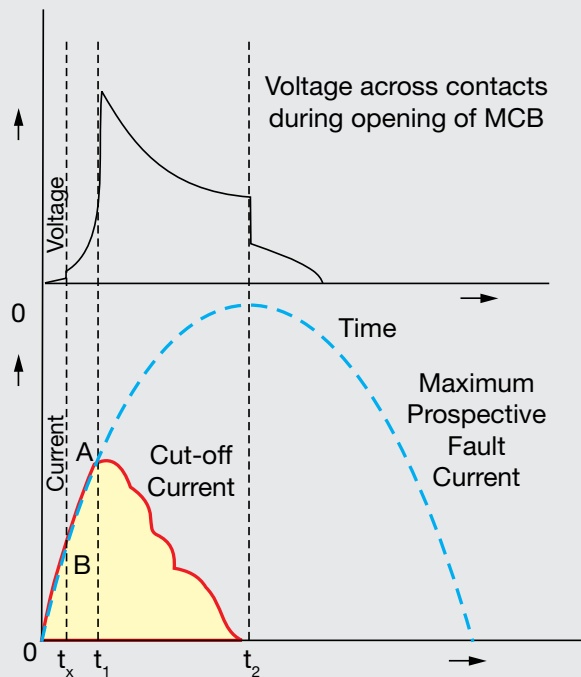

## Hammer Trip Mechanism

Current Limiting design in itself may not fulfill the requirement of quick breaking (instantaneous action) mainly due to inertia of the Latch mechanism and interconnected sequence of operations.

A Hammer directly connected to the plunger strikes the moving contact arm with a force proportional to the peak current there by forcibly separating the moving contact from the fixed contact much before the latch mechanism operates. This further reduces the opening time of the circuit breaker.

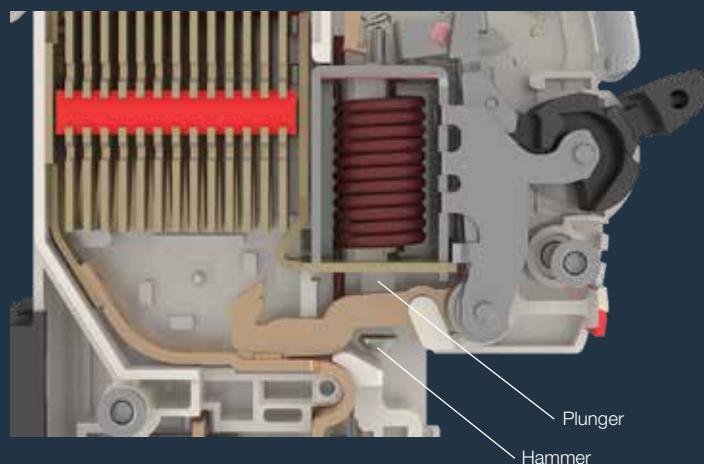

Ambient Temperature Compensation / Diversity Factor Chart  
Maximum Permissible Rated Current ( $K_1$  Factor)

Diversity Factor ( $K_2$  Factor)

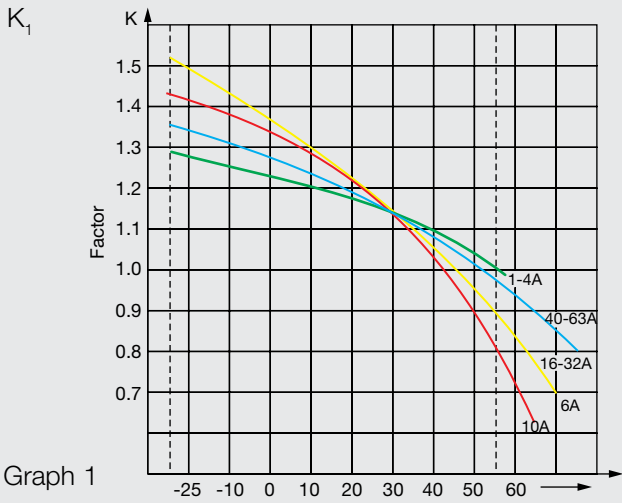

Graph 1

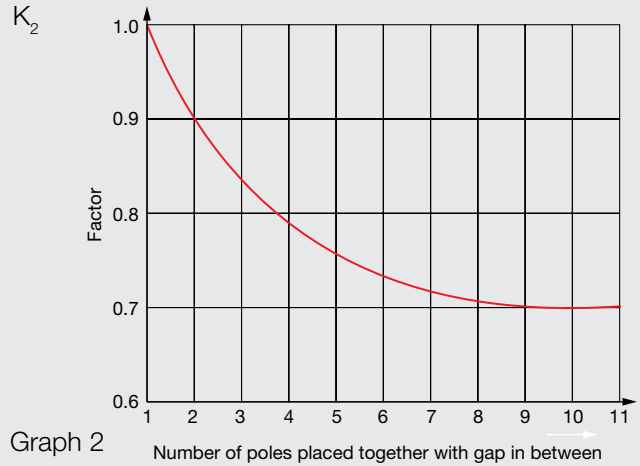

Graph 2

Calculation  $I_n / \text{MCB} = K_1 \times K_2 \times I_n$

Example 4 MCBs with  $I_n = 10$  A, and the ambient temperature is  $50^\circ\text{C}$  kept with no gap in between

Solution  $K_1 = 0.89$  (from graph 1)

$K_2 = 0.78$  (from graph 2)

$I_n / \text{pole} = 0.89 \times 0.78 \times 10 = 6.94$  A

thus from this we know that if we use more than 2 MCB together, their rating gets effected.

Effect Of Frequency Variation

MCBs are designed to operate at AC frequency 50/60 Hz. However, MCBs specially suitable for DC applications and for frequencies up to 400 Hz can be supplied on request.

These can be used on different frequencies in supply from  $16\frac{2}{3}$  - 60 Hz without any duration.

For higher frequencies, normal MCBs can be used with a multiplication factor which shall only affect its magnetic trip current.

Energy Limiting Class 3

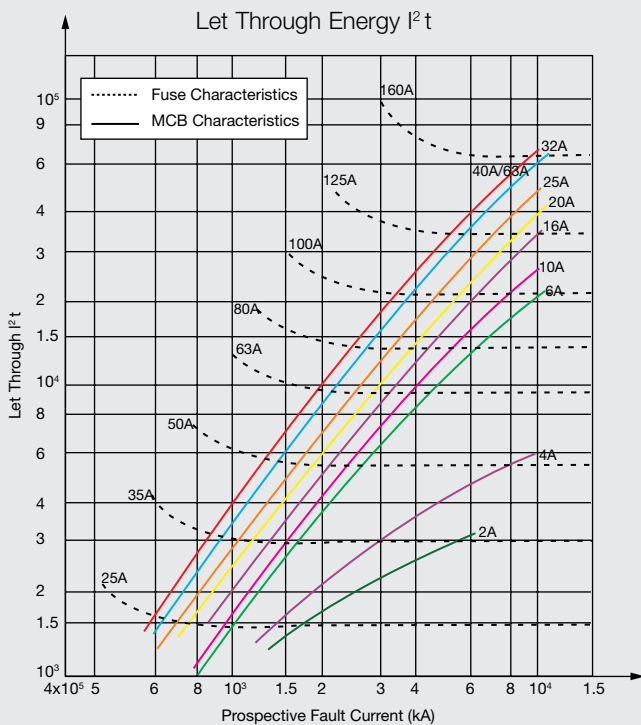

MCBs are designed to have low-let through energy during faults, thus ensuring a better protection of cables and equipment.

Supply	AC			DC
Frequency	100 Hz	200 Hz	400 Hz	
Multiplication Factor	1.1	1.2	1.5	1.5

Maximum Backup Protection

At site, no. of MCBs are used for outgoing connection. To protect the MCBs under short circuit (higher breaking capacity), we need to put fuses in the incoming side. The current rating of fuses should not be more than the values given in the table.

MCB Current Rating	Backup Fuse Rating
1 A	25 A
2 A	35 A
4 A	50 A
6 A	80 A
10 A-63 A	100 A



## Power Loss Details

The power loss of circuit breakers is closely controlled by the Standards and is calculated on the basis of the voltage drop across the main terminals measured at the rated current. The power loss of Havells circuit breakers is much lower than that required by the IS/IEC Standard, giving the benefit of cooler running and reduced heating effects when mounted in groups.

Rated Current In (A)	Power Loss Per Pole (W)
0.5 A	1.1 W
1 A	1.2 W
2 A	1.3 W
3 A	1.8 W
4 A	2.2 W
5 A	2.5 W
6 A	1.9 W
10 A	1.5 W
16 A	2.1 W
20 A	2.2 W
25 A	2.5 W
32 A	3.4 W
40 A	3.9 W
50 A	4.10 W
63 A	7.5 W

# HIGHER CURRENT MCB (80 A-125 A)

Technical Specification	
Reference Standard	IEC 60947-2
Type / Series	C curve
No. of Poles	1P, 2P, 3P, 4P
Rated Current (In)	80 A, 100 A, 125 A
Rated Voltage (Ue)	240 V ac / 415 V ac
Rated Frequency (f)	50 Hz
Rated Ultimate Short Circuit Breaking Capacity (Icu)	10 kA
Rated Service Short Circuit Breaking Capacity (Ics)	75% of Icu
Magnetic Release Setting	(5-10) In
Rated Insulation Voltage (Ui)	690 V
Rated Impulse Voltage (Uimp)	6 kV
Dielectric Strength	2.5 kV
Electrical / Mechanical Endurance (no. of operations) minimum	5000/20000
Operating Temperature	-5 °C to +55 °C
Humidity	95% RH
Energy Limit Class	3
Terminal Capacity (max)	50 mm <sup>2</sup>
Tightening Torque	3.5 N-m
Vibration	3 g
Shock Resistance	40 mm free fall
Protection Class	IP 20
Positive Contact Indication	Yes, Through Flag Indication (Red-ON, Green-OFF)
Net Weight / Pole in g	150 g
Dimensions (H x D x W) / Pole in mm	81 mm x 64.3 mm x 26.5 mm
Mounting	Clip on DIN Rail (35 mm x 7.5 mm)
Installation Position	Vertical / Horizontal
Case & Cover	Moulded, flame retardant thermoplastic material
Bus bar Connections Top Side	Pin Type
Bus bar Connections Bottom Side	Pin Type

## Dimensions (in mm)

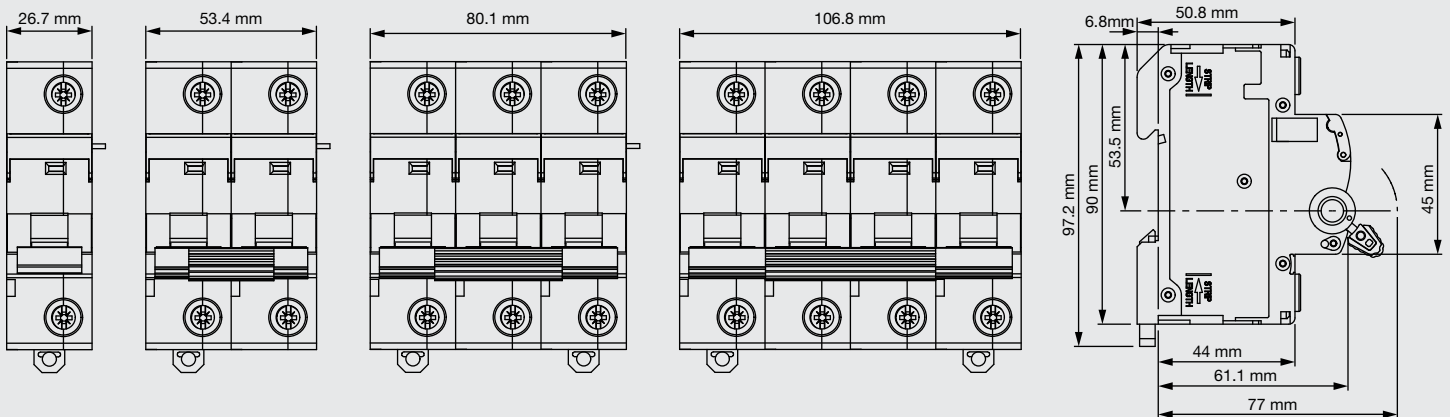

## DC Application

MCBs for DC application are specially designed to meet tough arc quenching conditions. While selecting circuit breaker for DC applications following parameters have to be taken into consideration.

### Normal Circuit Currents

The rating and normal running temperature of the MCB are unaffected by DC. The MCB can be selected using the thermal section of the standard time / current curves .

Magnetic tripping on DC is different from the equivalent AC by a peak factor of 1.4

ie., for 'B' curve AC MCB, magnetic range =  $(3-5)I_n$

for DC MCB, magnetic range =  $1.4(3-5)I_n = (4-7)I_n$

for 'C' curve AC MCB, magnetic range =  $(5-10)I_n$  for DC MCB, magnetic range =  $1.4(5-10)I_n = (7-14)I_n$

### Short Circuit Currents

The maximum short circuit current possible on a DC system is determined by the voltage of the battery and the total internal resistance of the cells.

It is given by Ohm's law :  $I_{sc} = V_b/R_b$

Where,  $I_{sc}$  is the Short Circuit Current

$V_b$  is the voltage of the battery (with 100% charged battery)

$R_b$  is the internal resistance of the battery cells

(this is usually stated by the manufacturer)

### Circuit Time Constant

The time constant is given by :  $L/R = 15$  ms max where L is the inductance of the circuit

### R is The Resistance Of The Circuit

The time constant is usually given in milliseconds (ms.). Ideally, DC circuits would be mainly resistive (i.e. a low number), as inductive circuits produce a back emf when the current suddenly falls. This in turn tends to prolong arcing during switching operations, and so reduce contact life.

### Circuit Voltage

The voltage of the circuit is dependent upon the power supply. The lower the voltage the easier switching operations will be, but the voltage makes no difference to the running of the MCBs.

Contact life can be significantly increased by reducing the voltage, drop across each pole. This can be achieved by wiring poles in series.

Standard Conformity	IEC 60947-2
Rated Current (In)	16 A, 20 A, 25 A, 32 A, 40 A, 50 A, 63 A*
Rated Voltage (Ue)	2P 500 V dc & 4P 1000 V dc
No. of Poles (Execution)	2P & 4P
Rated Short Circuit Breaking Capacity	6 kA

Correct polarity connections for DC MCBs

- Connection diagram

\*63 A available in DP only.

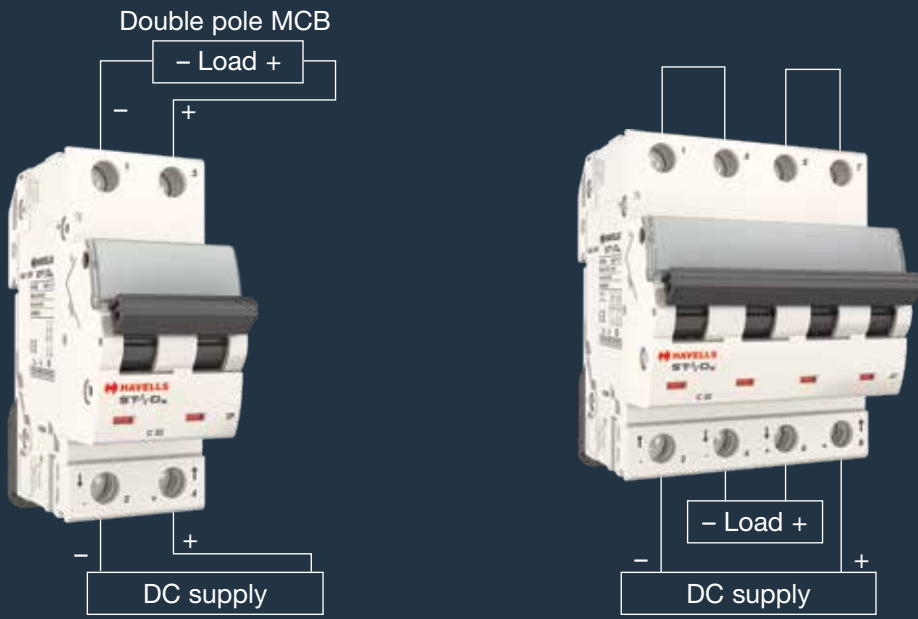

### Circuit Diagrams

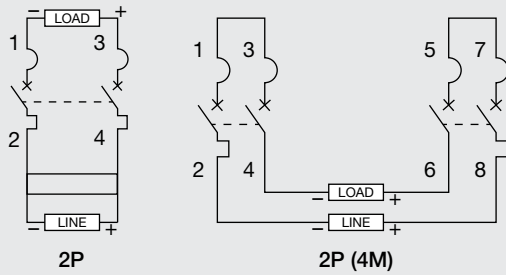

### Dimensions (in mm)

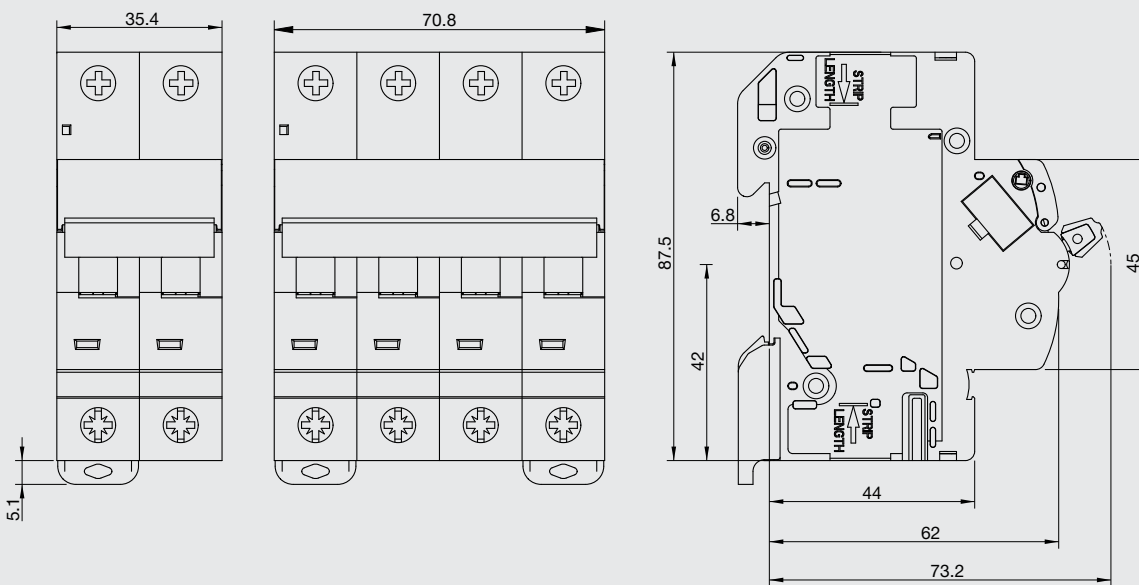

<b>Technical Specification</b>	
Reference Standard	IEC 60947-2
Type / Series	<b>ST-D<sub>x</sub></b>
No. of Poles	2P & 4P
Rated Current (In)	16 A, 20 A, 25 A, 32 A, 40 A, 50 A & 63 A*
Rated Voltage (Ue)	2P 500 V dc & 4P 1000 V dc
Rated service short circuit breaking capacity (Ics)	75% of Icu
Rated Short Circuit Breaking Capacity (Icu)	6 kA
Magnetic Release Setting	7 In
Rated Insulation Voltage (Ui)	500 V
Dielectric Strength	2.5 kV
Electrical / Mechanical Endurance (no. of operations) minimum	1500/8500 (No. of operations)
Rated Impulse Voltage (Uimp)	4 kV
Operating Temperature	-5 °C to 55 °C
Humidity	95% RH
Energy Limit Class	3
Terminal Capacity (max)	35 mm <sup>2</sup> , with Ag plated
Tightening Torque	2 N-m
Terminal/Polarity marked	Yes
Vibration	3 g
Positive Contact Indication	Yes, Through Flag Indication (Red-ON, Green-OFF)
Shock Resistance	40 mm free fall
Protection Class	IP20
Dimensions (H x D x W) / Pole in mm	87.5 mm x 62 mm x 17.7 mm
Mounting	Clip on DIN Rail (35 mm x 7.5 mm)
Installation Position	Vertical / Horizontal
Case & Cover	Moulded, flame-retardant thermoplastic material
Busbar Connections Top Side	Pin
Busbar Connections Bottom Side	Pin / Fork Type
Reference Temp. /Calibration Temp.	30 °C

\*63 A available in DP only.

## MCB Selection Chart

Appliances	Capacity / W (Load) (240 V~ 1 phase)	Current Rating of MCB	Type of MCB
Air Conditioner	3.5 kW	10 A*	"C" series
	5.28 kW	16 A*	"C" series
	7.03 kW	20 A*	"C" series
Refrigerator	165 L	3 A*	"C" series
	350 L	4 A*	"C" series
Oven cum Griller	4500 W	32 A	"C" series
	1750 W	10 A	"C" series
Oven only Hot Plate only Room Heater	750 W	6 A	"C" series
	2000 W	10 A	"C" series
	1000 W	6 A	"C" series
	2000 W	10 A	"C" series
Washing Machine	300 W	2 A	"C" series
Washing Machine (with heater)	1300 W	8 A	"C" series

\* It may vary from manufacturer to manufacturer. Please check before installation.

## Selection of MCB for Motor Protection

S. No.	kW	HP	1 Phase 230 V DOL Starting		3 Phase 400 V DOL Starting		3 Phase 400 V Assisted Starting Star Delta		
			Full Load Current	MCB Selection	Full Load Current	MCB Selection	Full Load Current	MCB Selection	
1	0.18 kW	0.24 HP	2.8 A	10 A	0.9 A	2 A	—	—	—
2	0.25 kW	0.34 HP	3.2 A	10 A	1.2 A	2 A	—	—	—
3	0.37 kW	0.50 HP	3.5 A	10 A	1.2 A	2 A	—	—	—
4	0.55 kW	0.74 HP	4.8 A	16 A	1.8 A	3 A	—	—	—
5	0.75 kW	1.01 HP	6.2 A	20 A	2.0 A	3 A	—	—	—
6	1.1 kW	1.47 HP	8.7 A	25 A	2.6 A	6 A	—	—	—
7	1.5 kW	2.01 HP	11.8 A	32 A	3.5 A	10 A	—	—	—
8	2.2 kW	2.95 HP	17.5 A	50 A	4.4 A	10 A	—	—	—
9	3 kW	4.02 HP	20.0 A	63 A	6.3 A	16 A	6.3 A	16 A	10 A
10	3.75 kW	5.03 HP	24.0 A	80 A	8.2 A	20 A	8.2 A	20 A	10 A
11	5.5 kW	7.37 HP	26.0 A	80 A	11.2 A	25 A	11.2 A	32 A	16 A
12	7.5 kW	10.05 HP	47.0 A	125 A	14.4 A	40 A	14.4 A	40 A	25 A
13	10 kW	13.40 HP	—	—	21.0 A	50 A	21.0 A	50 A	32 A
14	15 kW	20.11 HP	—	—	27.0 A	100 A	27.0 A	63 A	40 A
15	18.5 kW	24.80 HP	—	—	32.0 A	125 A	32.0 A	—	50 A
16	22 kW	29.49 HP	—	—	38.0 A	125 A	38.0 A	—	63 A
17	30 kW	40.21 HP	—	—	51.0 A	125 A	51.0 A	—	63 A

### Calculation Formulae:

Incomer Current Rating, For Single Phase:

$$\frac{\text{Total Load in W}}{240 \text{ V}}$$

Incomer Current Rating, For Three Phase:

$$\frac{\text{Total Load in W}}{\sqrt{3} \times 415 \text{ V}}$$

Note : One lighting circuit can have up to 800 W or up to 10 lighting points

One power circuit can have up to 2000 W or 1 power points



## Discrimination Data

MCB Downstream	MCB Upstream 'C' Curve							
'C' Curve	10 A	16 A	20 A	25 A	32 A	40 A	50 A	63 A
0.5 A to 5 A	50 A	80 A	100 A	125 A	160 A	200 A	250 A	315 A
6 A		80 A	100 A	125 A	160 A	200 A	250 A	315 A
10 A			100 A	125 A	160 A	200 A	250 A	315 A
16 A					160 A	200 A	250 A	315 A
20 A						200 A	250 A	315 A
25 A							250 A	315 A
32 A								315 A
40 A								
50 A								

MCB Downstream	MCCB Upstream																				
'C' Curve	16 A	20 A	25 A	32 A	40 A	50 A	63 A	80 A	100 A	125 A	160 A	200 A	250 A	320 A	400 A	500 A	630 A	800 A	1000 A	1250 A	1600 A
0.5 A to 6 A	1100 A	1200 A	1400 A	1700 A	2000 A	2500 A	3400 A	4800 A	5800 A	6700 A	T	T	T	T	T	T	T	T	T	T	T
10 A	-	1100 A	1200 A	1400 A	1700 A	2100 A	2500 A	3000 A	3500 A	4300 A	T	T	T	T	T	T	T	T	T	T	T
16 A	-	-	-	1300 A	1600 A	1900 A	2100 A	2400 A	2700 A	3200 A	8300 A	T	T	T	T	T	T	T	T	T	T
20 A	-	-	-	-	1600 A	1900 A	2100 A	2400 A	2700 A	2500 A	8300 A	T	T	T	T	T	T	T	T	T	T
25 A	-	-	-	-	-	1700 A	1800 A	2000 A	2200 A	2500 A	5400 A	8700 A	T	T	T	T	T	T	T	T	T
32 A	-	-	-	-	-	-	1800 A	2000 A	2200 A	2500 A	5400 A	8700 A	T	T	T	T	T	T	T	T	T
40 A	-	-	-	-	-	-	-	1500 A	1700 A	2000 A	4300 A	7000 A	T	T	T	T	T	T	T	T	T
50 A	-	-	-	-	-	-	-	-	1300 A	1500 A	3600 A	5900 A	9000 A	T	T	T	T	T	T	T	T
63 A	-	-	-	-	-	-	-	-	-	1100 A	2800 A	5200 A	8200 A	T	T	T	T	T	T	T	T

Prospective Fault Levels to which selectivity is achieved ( T = Total Selectivity )

## Discrimination with Fuses HRC Fuse Upstream Type gG

MCB Downstream	HRC Fuse Link Upstream									
'C' Curve	20 A	25 A	32 A	40 A	50 A	63 A	80 A	100 A	125 A	160 A
0.5 A to 6 A	700 A	850 A	960 A	1200 A	1350 A	1750 A	2800 A	4500 A	5200 A	6000 A
10 A		700 A	960 A	1200 A	1350 A	1750 A	2800 A	4500 A	5200 A	6000 A
13 A			850 A	1200 A	1200 A	1750 A	2800 A	4500 A	5200 A	6000 A
16 A				960 A	1100 A	1500 A	2500 A	3200 A	5200 A	6000 A
20 A					1100 A	1500 A	2500 A	3200 A	4500 A	5200 A
25 A					960 A	1350 A	2000 A	3200 A	4500 A	5200 A
32 A						1200 A	1750 A	2800 A	4500 A	5200 A
40 A							1750 A	2800 A	4500 A	5200 A
50 A								2500 A	3200 A	4500 A
63 A									3200 A	4500 A

## AUXILIARY CONTACT

### Dimensions (in mm)

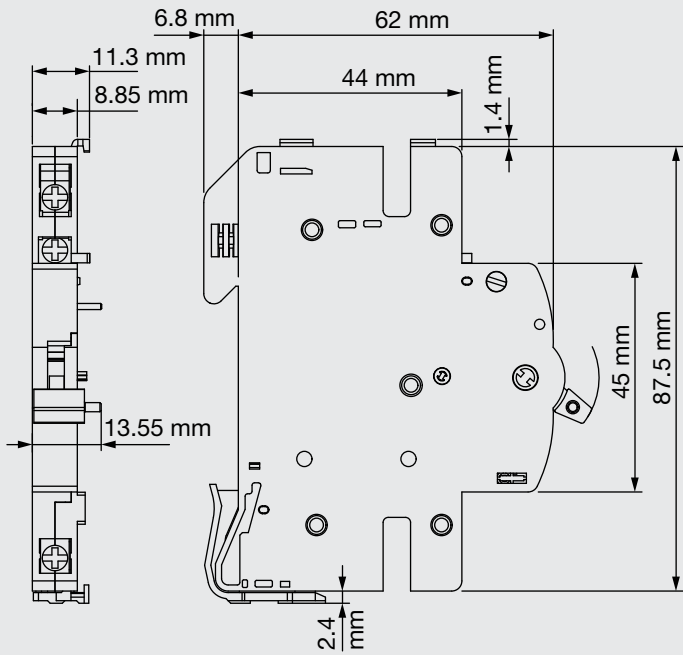

### Circuit Diagram

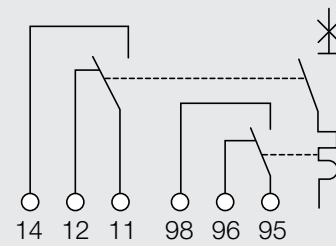

## SHUNT TRIP

### Dimensions (in mm)

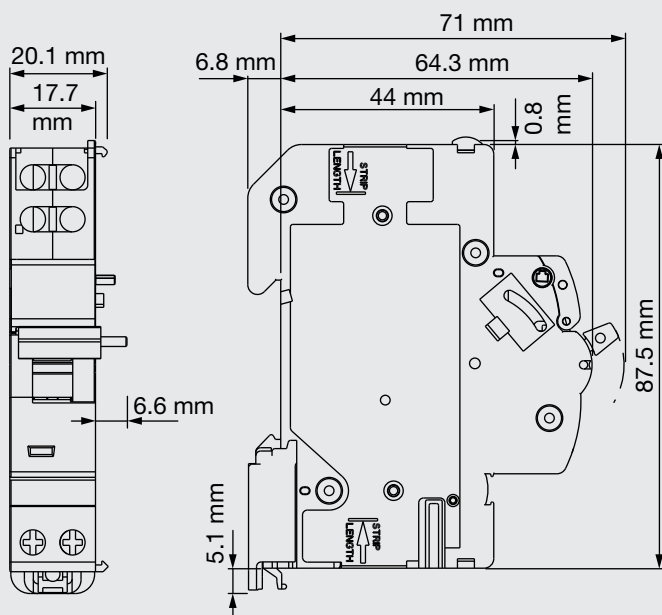

Single Phase

### Circuit Diagram

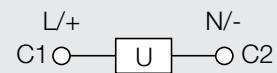

## UNDER VOLTAGE TRIP

### Dimensions (in mm)

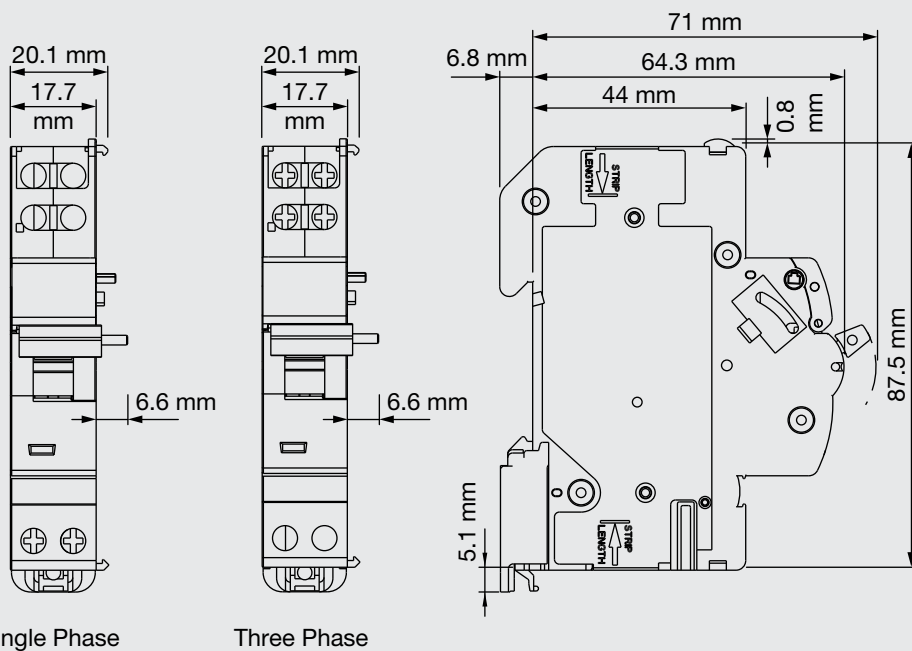

### Circuit Diagram

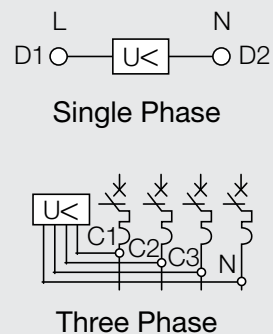

## UNDER VOLTAGE TRIP + TIME DELAYED

### Dimensions (in mm)

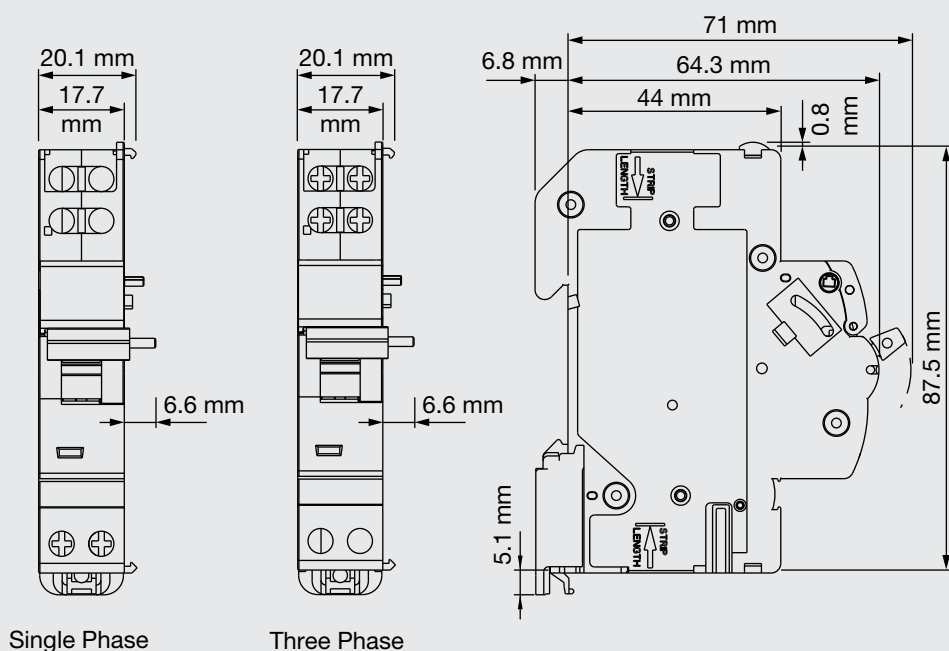

### Circuit Diagram

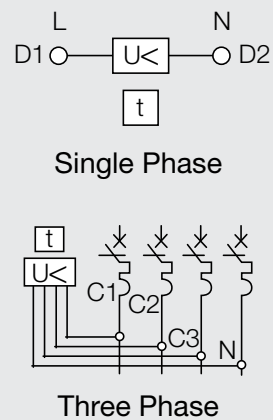

## OVER VOLTAGE TRIP

### Dimensions (in mm)

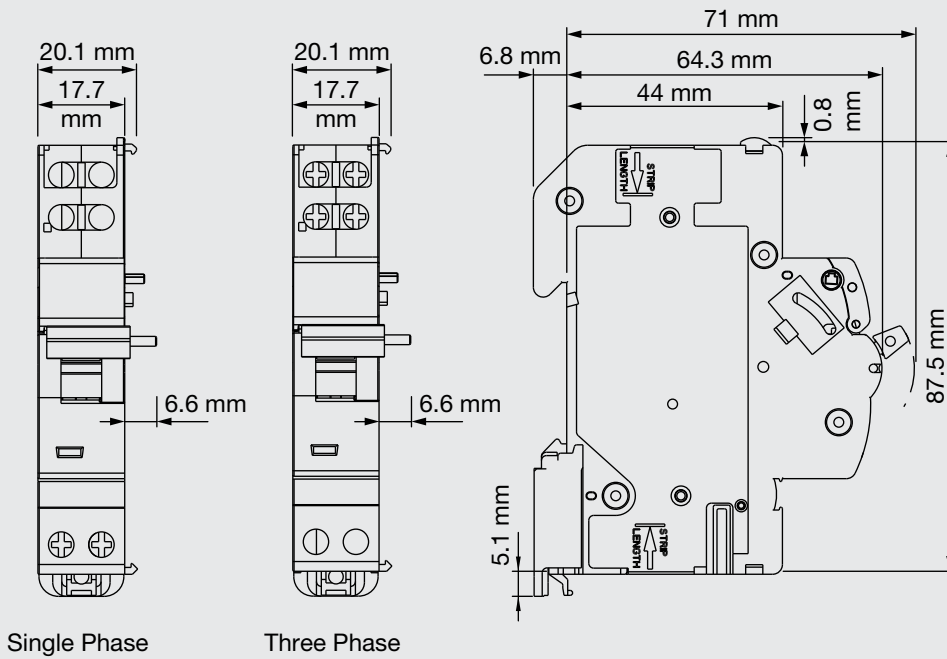

### Circuit Diagram

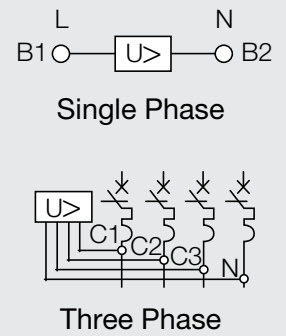

## UNDER VOLTAGE TRIP + OVER VOLTAGE TRIP

### Dimensions (in mm)

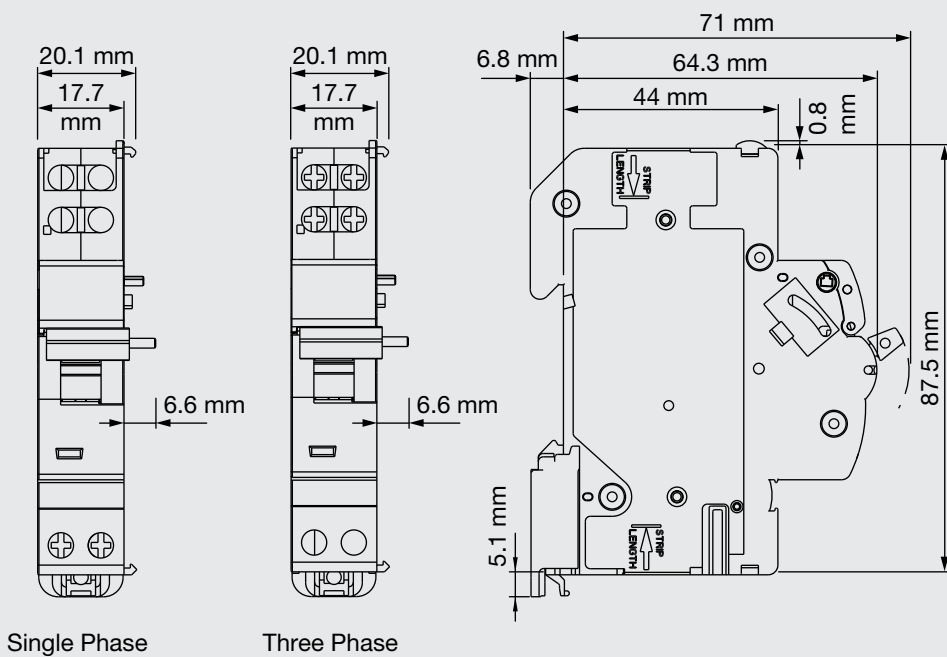

### Circuit Diagram

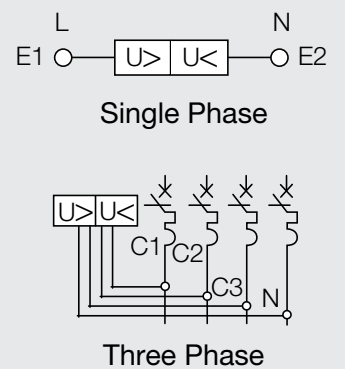

PHASE LOSS

Dimensions (in mm)

Circuit Diagram

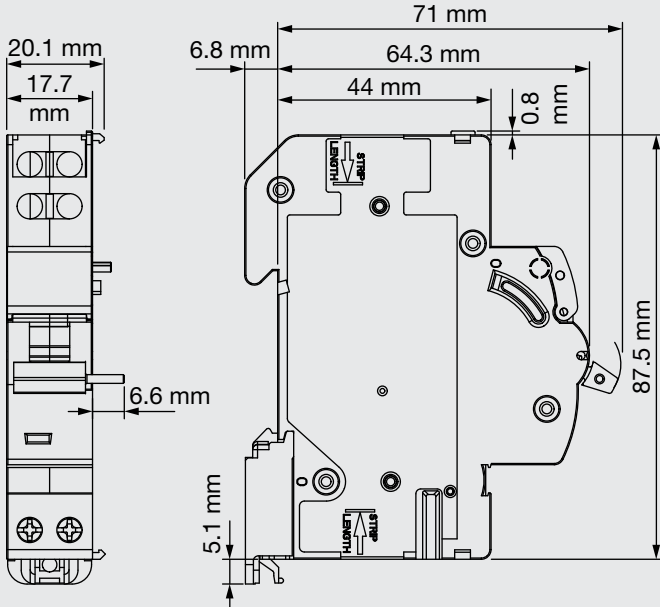

Single Phase



# RESIDUAL CURRENT CIRCUIT BREAKER

The use of exposed, substandard, badly wired, wrongly connected or damaged equipment as well as frayed or badly repaired cables reduces the safety of an installation and increases the risk of person receiving an electric shock. RCCBs are electrical devices which afford a very high degree of protection against the risks of electrocution and fire caused by earth faults.

## Protection Against Electrocution

Electrocution is a passage of current through human body, which is dangerous. The flow of current through human body affects vital functions of breathing & heartbeat.

Effect of electric current through human body has been well researched and following chart summarizes the results:

500 mA			Immediate cardiac arrest resulting in death
70 mA-100 mA			Cardiac fibrillation; the heart begins to vibrate and no longer beats at a steady rate. This situation is dangerous since it is irreversible
20 mA-30 mA			Muscle contraction can cause respiratory paralysis
10 mA			Muscle contraction : the person remains "stuck" to the conductor
1 mA-10 mA			Prickling sensations

However, electrocution should not be viewed in terms of "current" alone, but in terms of "contact voltage". A person gets electrocuted by coming in contact with an object that has a different potential from his/her own. The difference in potential causes the current to flow through the body.

The human body has known limits:

- Under normal dry conditions, voltage limit = 50 V
- In damp surroundings, voltage limit = 25 V

A correctly chosen RCCB can detect small currents flowing to earth and reduces the risk of electrocution.

## Protection Against Indirect Contact

Over current protection devices like MCB are unable to act promptly on small earth leakage currents. To comply with wiring regulations, the earth fault loop impedance in Ohms, multiplied by the rated tripping current of the RCD in amperes must not exceed 50.

Example

For an RCD with a rated tripping current of 30 mA, the maximum permissible earth fault loop impedance is calculated as follows:  
 $Z_s (\text{max}) = 50 / I_{\Delta n} = 50 / 0.03 = 1,666 \Omega$

## Protection Against Fire

The majority of fires which occur as a result of faulty wiring are started by current flowing to earth. Fire can be started by fault current of less than 1 ampere. The normal domestic overload protective device such as a fuse or MCB will not detect such a small current. A correctly chosen RCD will detect this fault current and interrupt the supply, hence, reducing the risk of a fire starting.

## Maximum Earth Fault Loop Impedances

Rated residual operating current $I_{\Delta n}$	- 5 °C 25 V	- 5 °C 50 V
0.03 A	830 $\Omega$	1660 $\Omega$
0.10 A	250 $\Omega$	500 $\Omega$
0.30 A	83 $\Omega$	166 $\Omega$
0.50 A	50 $\Omega$	100 $\Omega$



## Working Principle

Residual current circuit breaker (abbr. RCCB) continuously establish the total of the momentary values of all currents flowing via the active conductors to an electrical installations operated by an earthed AC mains supply. According to Kirchhoff's first law, this total must always be zero. In the event of a short-to-earth due to defective insulation, such currents will not total zero, because – depending upon the fault resistance  $R_F$  and the ground circuit resistance  $R_A$  – a residual current, also called fault current, will not flow via the active conductors but return via the earth to the power supply. If the r.m.s. Value of the residual current exceeds the rated residual operating current in the RCCB, then the latter will trigger the disconnection of the installation from the power supply.

### RCCB Protection at Direct Contact

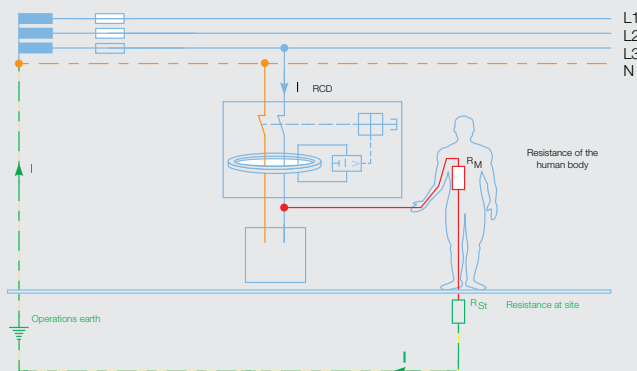

### RCCB Protection at Indirect Contact

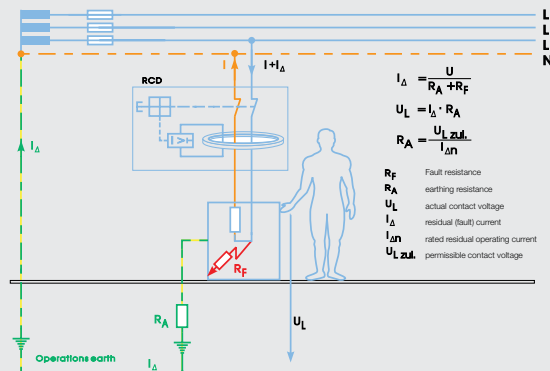

## Sensitivity Selection

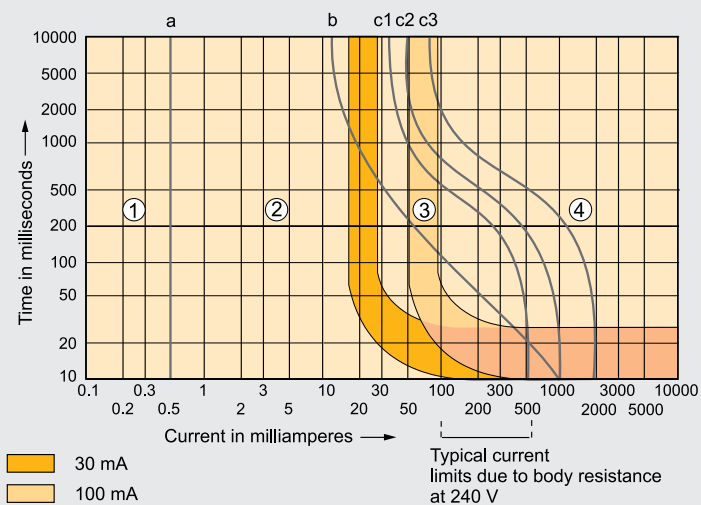

- Zone Physiological Effects
- Zone 1 Usually no reactions
  - Zone 2 Usually no harmful physiological effects
  - Zone 3 Usually no organic damage to be expected. Likelihood of muscular contraction and difficulty in breathing, reversible disturbances of formation and conduction of impulse in the heart and transient cardiac arrest without ventricular fibrillation increases with current magnitude and time.
  - Zone 4 In addition to the effects of Zone 3, probability if ventricular fibrillation increased up to 5% (curve  $C_2$ ) up to 50% (curve  $C_3$ ) and above 50% beyond curve  $C_3$ . It increases with magnitude and time, and patho physiological effects such as cardiac arrest, breathing arrest and heavy burns may occur.

## Actuation Time Characteristics

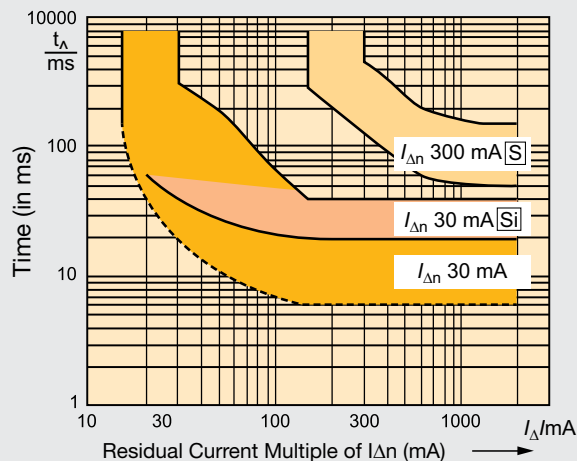
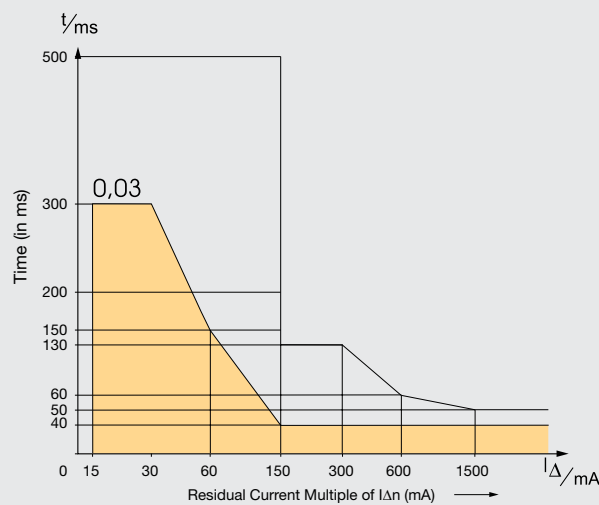

- **30 mA**

A 30 mA RCCB will provide a high degree of protection against electrocution in an accidental shock hazard situation. The current flowing through human body could be between 80 mA and 240 mA depending on the resistance of the human body and the voltage across it.

To be within zone of the IEC curve, It is necessary for the RCCB to operate within 50 ms at 240 mA and 150 ms at 80 mA. Both these conditions are satisfied by 30 mA RCCB.

For households, individual outlets, wet areas and temporary installations, RCCB with sensitivity not exceeding 30 mA is advisable.

- **100 mA**

A 100 mA RCCB will normally give high degree of protection against electrocution but there is a possibility that the shock current could fall below the tripping level of RCCB. This could occur if additional resistances to that of human body are included in the earth path.

The 100 mA RCCB protects against leakage currents and indirect contact with earth loop impedance up to 500 Ohm.

- **300 mA/500 mA**

A 300 mA/500 mA RCCB may be used where only fire protection is required. e.g., on lighting circuits, where the risk of electric shock is small. 300 mA/500 mA RCCB will not give any protection against electrocution.

## **Selection of RCCB Type**

RCCB Type AC

AC Type RCCB are used for residual sinusoidal alternating current.

RCCB Type A

A Type RCCB is used for residual sinusoidal alternating currents and residual pulsating direct currents, whether suddenly applied or slowly rising. It can therefore handle the residual current waveforms which can occur in the power supply units of single-phase loads with electronic components (e.g. ECG, dimmer switches). This type of residual current protective device is suitable for electronic equipment with input current circuits 1 to 6 in table 1.

RCCB Type B:

B type RCCB is used for all types of residual currents i.e. alternating, pulsating direct and smooth direct residual current and residual pulsating rectified direct current which results from one or more phases, high frequency and mixed frequency residual currents. They are also resistant to tripping by leakage currents in circuits with power frequency inverters (according to IEC/EN 62423).

High Level immunized RCDs (Type A-HLi)

This version is more resistant to unwanted tripping than Standard types (both AC & A).It provides the best consent between safety and continuity in service by providing more resistance to unwanted tripping.

They are mainly designed to avoid nuisance tripping and for harsh electromagnetic environment i.e. in case of high frequency transient currents as well.

Application: Residential, commercial, Industrial

Standard: IEC/EN 61008



Immunity of Havells A-HLI residual currents to nuisance tripping in all cases interference indicated below











Interference	Non-tripping test conditions	Performance required by the IEC 61008/61009 series of standards	Performance of Havells Electric A-HLI type residual current devices
Continuous interference			
Flow of harmonic currents to earth	1 kHz sine wave	None	8 x I <sub>Δn</sub>
Transient interference			
Voltage surge induced by a lightning strike	Voltage surge (1.2/50 μs) (IEC/EN 61000-4-5)	4 kV between conductors (differential mode) 5 kV between all conductors together and ground (common mode)	4.5 kV between conductors (differential mode) 5.5 kV between all conductors together and ground (common mode)
Current induced by a lightning strike	Current surge 8/20 μs pulse	250 A peak	3 kA
Operating transient current, indirect lightning strike current	Current waveform: 0.5 μs/100 kHz (IEC/EN 61008)	200 A peak	400 A peak
Surge protective device operation downstream of the RCD, switching on capacitors	10 ms current pulse (half sinusoidal wave)	None	500 A peak
<b>Electromagnetic compatibility</b>			
Switching of inductive loads, fluorescent lighting, motors, etc.	Repeated bursts (IEC 61000-4-4)	4 kV/2.5 kHz	5 kV/2.5 kHz 4 kV/400 kHz
Immunity against superimposed 1 kHz to 150 kHz conducted RF waves	Superimposed current 1 kHz to 150 kHz conducted RF waves to 0.3 I <sub>Δn</sub> 50 Hz (IEC 61000-4-16) Non Tripping (Tripping test at 1.25 I <sub>Δn</sub> 50 Hz)	Level 3	Level 3
Fluorescent lighting, circuits controlled by thyristors	Conducted current 150 kHz to 80 MHz RF waves (IEC 61000-4-6)	3 V (IEC) 3 V (EN)	30 V
Radio waves (TV and radios, transmitters, telecommunication, etc..)	Radiated fields 80 MHz to 1-6 GHz RF waves (IEC 61000-4-3)	3 V/m (IEC) 10 V/m (EN)	30 V/m

Type F RCD:

Type F residual current protective devices detect all residual current types as do type A. Additionally they are suitable for detecting residual currents from mixed frequencies upto 1 kHz.

### Type of wave form detected by RCCB and its classification

Residual current with different waveforms can occur depending upon the electronic switching in the electrical circuit.

Waveform definition	Current waveform	Type AC	Type A	Type A-HLi	Type F	Type B	Tripping current
Sine wave		✓	✓	✓	✓	✓	0.5 to 1 I <sub>Δn</sub>
Pulsating half wave		✗	✓	✓	✓	✓	0.35 to 1.4 I <sub>Δn</sub>
Pulsating 90°/135° wave		✗	✓	✓	✓	✓	Current delay angle 90°: 0.25 to 1.4 I <sub>Δn</sub>
		✗	✓	✓	✓	✓	Current delay angle 135°: 0.11 to 1.4 I <sub>Δn</sub>
Pulsating Half wave + direct current (6 mA)		✗	✓	✓	✓	✓	max 1.4 I <sub>Δn</sub> + 6 mA
Pulsating Half wave + direct current (10 mA)		✗	✗	✓	✓	✓	max 1.4 I <sub>Δn</sub> + 10 mA
Composite wave		✗	✗	✗	✓	✓	0.5 to 1.4 I <sub>Δn</sub>
High frequency (up to 1 kHz)		✗	✗	✗	✗	✓	Current frequency 150 Hz 0.5 to 2.4 I <sub>Δn</sub>
		✗	✗	✗	✗	✓	Current Frequency 150 Hz 0.5 to 2.4 I <sub>Δn</sub>
		✗	✗	✗	✗	✓	Current Frequency 150 Hz 0.5 to 2.4 I <sub>Δn</sub>
Two phase rectified full wave		✗	✗	✗	✗	✓	0.5 to 2 I <sub>Δn</sub>
Three phase rectified full wave		✗	✗	✗	✗	✓	0.5 to 2 I <sub>Δn</sub>
Direct current		✗	✗	✗	✗	✓	0.5 to 2 I <sub>Δn</sub>

### Selective RCDs (Type S)

Selective RCDs have delayed tripping action and are installed in upstream of other instantaneous residual current devices to guarantee selectivity. This intentional tripping time delay permits to realize the selectivity with downstream instantaneous devices and limit the power out only to the portion of the system affected by the fault. Mainly used as main switch as well as in combination with surge arresters and for protection against indirect contacts ( $\geq 100$  mA), protection of installations against risk of fire (300 mA or 500 mA)

Type A	I <sub>n</sub> (A)	I <sub>Δ</sub> (A)	Tripping times (s) × currents			
			1×I <sub>Δ</sub>	1×I <sub>Δ</sub>	1×I <sub>Δ</sub>	500 A
Generic	any	any	0.3	0.15	0.04	0.04
S (selective)	any	> 0.030	0.13-0.5	0.06-0.2	0.05-0.15	0.04-0.15

Application: commercial, Industrial

Standard: IEC/EN 61008

Surge Current Resistance (wave 8 μs/20 μs) = 5000 kA



## Selection Chart:

How to Select and install Residual Current devices to different loads  
Types of RCD (AC, A, A-HLi, F, B)

The increase in use of electronic loads can result in earth leakage current with different waveform characteristics. This situation must be carefully analyzed as it effects the performance of RCD.

Havells provides various equipment technologies capable of overcoming the consequences of interference of all kinds.

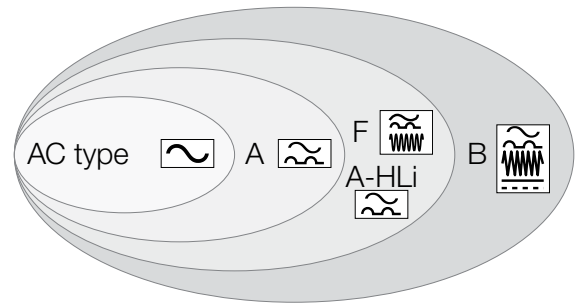

Operating conditions		Examples	Types					
			AC	A	A-HLi	F	B	
Load			AC	A	A-HLi	F	B	
	With no special characteristics	<ul style="list-style-type: none"> <li>General purpose power sockets</li> <li>Incandescent or LED lighting</li> <li>Class II consumer electronic: hair dryer, TV, etc.</li> <li>Electric heater, water heater</li> </ul>	✓	✓	✓	✓	✓	
	Including a rectifier	Single-phase	<ul style="list-style-type: none"> <li>Class I domestic appliances: induction cooking appliances, washing machines, tumble-dryer</li> <li>Single-phase UPS</li> <li>Single-phase photovoltaic system</li> <li>Machines including diodes, capacitors and rectifiers</li> <li>Motors</li> <li>Machine tools</li> </ul>	-	✓	✓	✓	✓
		Three-phase	<ul style="list-style-type: none"> <li>Three-phase variable speed industrial drives (motors: cranes, elevators, heating, ventilation, air conditioning, pumps)</li> <li>Single-phase/three-phase chargers for electric vehicles</li> <li>Three-phase UPS (rectifier and inverter)</li> <li>Motors: cranes, elevators, heating, ventilation, air conditioning (HVAC), pumps</li> <li>Three-phase photovoltaic system</li> <li>Medical equipment with DC current loads</li> </ul>	-	-	-	-	✓
	Generating high frequency interference (current peaks, harmonics)	<ul style="list-style-type: none"> <li>Single-phase variable speed industrial drives: air-conditioning, heating pump</li> <li>Powerful IT equipment, telecommunication equipment</li> <li>Heated floor</li> <li>Fluorescent lighting powered by a extra low voltage transformer, by electronic ballast</li> <li>Variable luminosity lighting</li> <li>Capacitor banks</li> <li>Freezer, cold room</li> </ul>	-	-	✓	✓	✓	
	Including an anti-harmonic filter in the power supply or with high availability requirement	<ul style="list-style-type: none"> <li>Computer peripheral devices (printers, scanners, etc.)</li> <li>Rack of computers and servers</li> <li>Hospital</li> <li>Supermarket cash registers</li> </ul>	-	-	✓	-	✓	
Electrical environment			AC	A	A-HLi	F	B	
	Vicinity of equipment generating transient overvoltages	<ul style="list-style-type: none"> <li>High-powered switching devices, medium voltage switchgear</li> <li>Reactive energy compensation banks</li> </ul>	-	-	✓	✓	✓	
	Circuits powered by an uninterruptible power supply	<ul style="list-style-type: none"> <li>Backed-up network</li> </ul>	-	-	✓	-	✓	
	"Isolated neutral" (IT) method of earthing	-	-	-	✓	-	✓	
	Risk of lightning strokes	<ul style="list-style-type: none"> <li>Buildings protected by a lightning protection system</li> <li>Mountainous or humid regions</li> <li>Regions with a high keraunic level</li> </ul>	-	-	✓	✓	✓	
Atmosphere			AC	A	A-HLi	F	B	
	Ambient temperature which could be less than -5°C	-	-	✓	✓	✓	✓	
	Severe environments whose code varies between AF2 and AF4 according to IEC 60364-5-51	<ul style="list-style-type: none"> <li>Indoor swimming pools</li> <li>Yatch harbours, marinas, camping grounds</li> <li>Water treatment</li> <li>Chemical industries, heavy industries, paper mills</li> <li>Mines and cellars, road tunnels</li> <li>Markets, stock raising, food-processing industries</li> </ul>	-	-	✓	✓	✓	

Technical Specification		
Data	AC, A Type, AC-HLi, A-HLi Type, F Type, AC-S, A-S Type	B Type
Reference Standard	IS 12640-1; IEC 61008-1	IS 12640-1; IEC 61008-1; IEC 62423
No. of Poles	2P, 4P	2P, 4P
Rated Current (In)	16 A, 25 A, 32 A, 40 A, 63 A	16 A, 25 A, 32 A, 40 A, 63 A
Rated Sensitivity (I $\Delta$ n)	AC, A Type -30 mA, 100 mA, 300 mA	30 mA, 300 mA
	AC-HLi, A-HLi Type - 30 mA, 100 mA, 300 mA	
	F Type - 30 mA, 100 mA, 300 mA	
	AC-S, A-S Type - 100 mA, 300 mA	
Rated Voltage (Ue)	240 V ac, 415 V ac	240 V ac, 415 V ac
Insulation Voltage (Ui)	690 V	690 V
Rated Frequency	50 Hz	50 Hz
Rated Conditional Short Circuit Current (Inc)	10 kA	10 kA
Rated Residual Making & Breaking Capacity (I $\Delta$ m)	500 A or 10 In whichever is greater	500 A or 10 In whichever is greater
Rated Impulse withstand Voltage (1.2 $\mu$ s /50 $\mu$ s)	4 kV	4 kV
Dielectric Strength	2.5 kV	2.5 kV
Surge Current withstand (8 $\mu$ s/20 $\mu$ s)	AC, A Type -250 A	3 kA
	AC-S, A-S Type -5 kA	
	AC-HLi, A-HLi Type -3 kA	
	F Type -3 kA	
Electrical Life	10000	10000
Mechanical Life	20000	20000
Protection Degree	IP 20	IP 20
Storage Temperature	-25 °C to +55 °C	-25 °C to +55 °C
Terminal Capacity (Max. in mm <sup>2</sup> )	35 mm <sup>2</sup>	35 mm <sup>2</sup>
Dimensions (H X D X W)	87.5 mm x 62 mm x 35.9 mm (for 2P); 87.5 mm x 62 mm x 71.8 mm (for 4P)	87.5 mm x 62 mm x 35.9 mm (for 2P); 87.5 mm x 62 mm x 71.8 mm (for 4P)
Mounting	Clip on DIN Rail (35 mm x 7.5 mm)	Clip on DIN Rail (35 mm x 7.5 mm)
Installation Position	Vertical / Horizontal	Vertical / Horizontal
Earth Leakage Protection Class	AC, A / AC-S, A-S / AC-HLi, A-HLi, F	B
Earth Leakage Protection Time Delay	AC, A Type- 1 I $\Delta$ n <300 ms, 5 I $\Delta$ n <40 ms	1 I $\Delta$ n <300 ms, 5 I $\Delta$ n <40 ms
	AC-HLi, A-HLi- 1 I $\Delta$ n <300 ms, 5 I $\Delta$ n <40 ms	
	F Type- 1 I $\Delta$ n <300 ms, 5 I $\Delta$ n <40 ms	
	AC-S, A-S - 130 ms <I $\Delta$ n <500 ms, 40 ms <5 I $\Delta$ n <150 ms	
Humidity	95% RH	95% RH
Tightening Torque	2 N-m	2 N-m
Vibration	3 g	3 g
Shock Resistance	40 mm free fall	40 mm free fall
Positive Contact Indication	Yes, Through Flag Indication (Red-ON, Green-OFF)	Yes, Through Flag Indication (Red-ON, Green-OFF)
Net Weight in kg	215 g (for 2P) ; 335 g (for 4P)	215 g (for 2P) ; 335 g (for 4P)
Case & Cover	Moulded, flame retardant thermoplastic material	Moulded, flame retardant thermoplastic material
Bus bar Connections Top Side	Pin / Fork Type	Pin / Fork Type
Bus bar Connections Bottom Side	Pin / Fork Type	Pin / Fork Type
Auxiliary Contacts	Yes	Yes



## HIGHER CURRENT RCCB (80 A-100 A)

Technical Specification	
Data	AC, A Type / AC-HLi, A-HLi Type / AC-S, A-S Type
Reference Standard	IS 12640-1 ; IEC 61008-1
No. of Poles	2P, 4P
Rated Current (In)	80 A, 100 A
Rated Voltage (Ue)	240 V ac, 415 V ac
Rated Sensitivity (IΔn)	AC, A Type - 30 mA, 100 mA, 300 mA
	AC-HLi, A-HLi Type - 100 mA, 300 mA
	F Type - 100 mA
	AC-S, A-S Type - 100 mA, 300 mA
Rated Voltage (Ue)	240 V ac, 415 V ac
Insulation Voltage (Ui)	690 V
Rated Frequency	50 Hz
Rated Conditional Short Circuit Current (Inc)	10 kA
Rated Residual Making & Breaking Capacity (IΔm)	10 In
Rated Impulse withstand Voltage (1.2 μs/50 μs)	4 kV
Dielectric Strength	2.5 kV
Surge Current withstand (8 μs/20 μs)	AC, A Type - 250 A
	AC-HLi, A-HLi Type - 3 kA
	AC-S, A-S Type - 5 kA
Electrical Life	5000
Mechanical Life	20000
Protection Degree	IP 20
Storage Temperature	-25 °C to +55 °C
Terminal Capacity (Max. in mm <sup>2</sup> )	35 mm <sup>2</sup>
Dimensions (H X D X W)	87.5 mm x 62 mm x 35.9 mm (for 2P); 87.5 mm x 62 mm x 71.8 mm (for 4P)
Mounting	Clip on DIN Rail (35 mm x 7.5 mm)
Installation Position	Vertical / Horizontal
Earth Leakage Protection Class	AC, A
	AC-HLi, A-HLi
	AC-S, A-S
Earth Leakage Protection Time Delay	AC, A Type - 1 IΔn < 300 ms, 5 IΔn < 40 ms
	AC-HLi, A-HLi Type - 1 IΔn < 300 ms, 5 IΔn < 40 ms
	AC-S, A-S Type - 130 ms < IΔn < 500 ms, 40 ms < 5 IΔn < 150 ms
Humidity	95% RH
Tightening Torque	2 N-m
Vibration	3 g
Shock Resistance	40 mm free fall
Positive Contact Indication	Yes, Through Flag Indication (Red-ON, Green-OFF)
Net Weight in kg	230 g (for 2P) ; 404 g (for 4P)
Case & Cover	Moulded, flame retardant thermoplastic material
Bus bar Connections Top Side	Pin / Fork Type
Bus bar Connections Bottom Side	Pin / Fork Type
Auxiliary Contacts	NO

## \*Reset Function

The switch mechanism of RCCBs in STADx range provides a reset function. The position of the switch lever indicates whether the RCCB has been switched off manually (position O) or as the result of a fault (central position). In order to cancel the central positioning the switch needs first to be moved to position 'O', only then can the RCCB be switched on again.

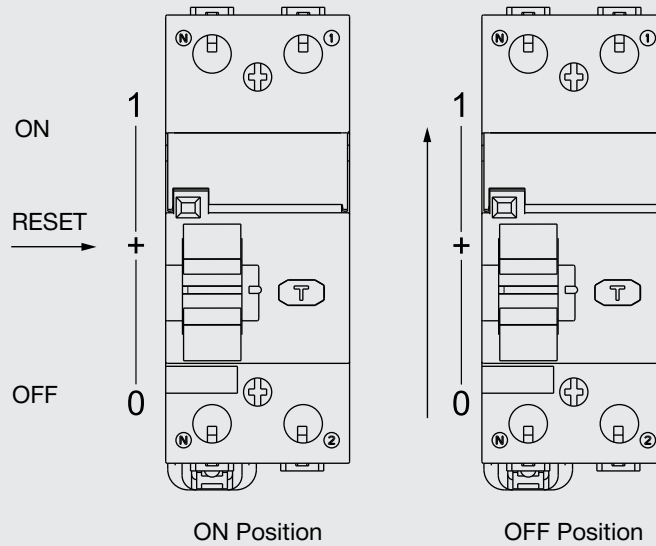

\* this feature is not applicable to S Type, HLI Type, F Type, B Type RCD's.

## Wiring Diagram

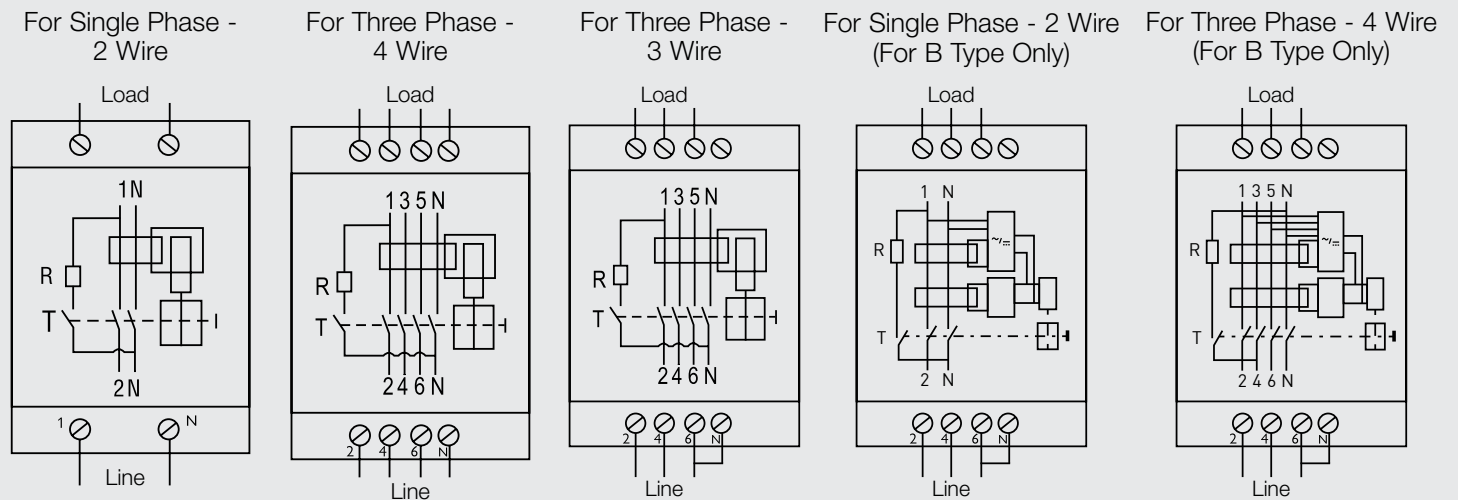

The Havells range of four pole RCCBs can be used to provide residual current protection in 3 phase, 3 wire circuits (no neutral), however a link from the neutral to an incoming should be made on the supply side of the RCCB, to enable the operation of the RCCB.



**Dimensions (in mm)**

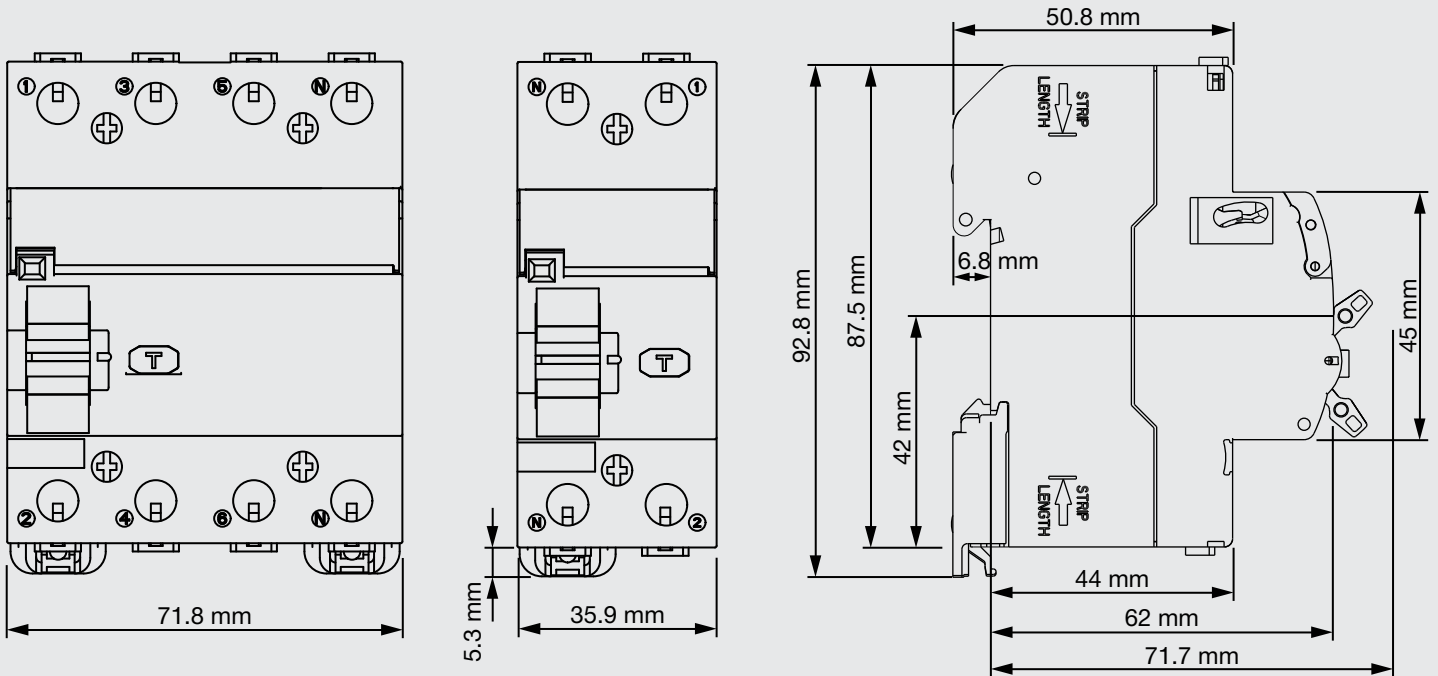

# Residual current circuit breaker With Overload & Short Circuit Protection

## Construction

Havells new RCBO is a single composite device which provides protection against over currents, short-circuit and earth leakage faults, it comes in the same width and profile as that of a standard MCB. It is designed for use in domestic, commercial and industrial distribution systems at the most downstream circuit for ensuring high degree of protection to the user for a particular circuit. In normal use, it is safe to use and poses no threat to user as well as to environment.

## Features

- Positive contact indication: Red for ON, Green for OFF
- Short circuit breaking capacity 10 kA.
- Large terminal capacity: RCBOs have 35 mm<sup>2</sup> for cool running while in operation.
- Protection in case of loss of supply neutral: Even in event of loss of supply neutral, Havells RCBO provides protection against earth faults. The Functional Earth (FE) white color wire connected to earth provides this protection.
- Controlled response & immunity to nuisance tripping: The trip level and the response time of the Havells VD (Voltage Dependent) RCBO using electronic circuit is set to very precise values and thereby provide greater immunity to nuisance tripping that can be caused by mains borne noise, surge voltages, lighting surges, reactive loads, mains filters, etc.
- Neutral to earth faults: A connection that occurs between N and E on the load side of any RCBO will impact on its performance and cause the trip level to increase. In the case of a N - E fault, the user may have no way of knowing that this fault exists and that the RCBO has been desensitized. Under this condition, the Havells VD RCBO provides a far greater level of protection than a normal VI (Voltage Independent) RCBO.

## Aesthetics & Convenience

- The new module's unique compact construction enables far more devices to be fitted into a distribution board than previously possible, and 2 Module RCBO can simply replace existing MCB 2 pole when upgrading a board.
- High stacking density = smaller chassis & distribution boards.

## Reliability & Continuity Of Service

- Enhanced discrimination with Havells MCBs
- Retrofits Havells MCBs in distribution boards with no modifications in general
- Robust construction.

## Energy Limiting

Havells RCBO meets the requirements for energy let through by IEC & British Standard for energy limiting class 3.

## Additional Range - Type A & S

Type A - Pulsating DC Protection: Any electrical appliance with power control has the ability to produce earth fault currents with pulsating DC (rectified AC) components. RCBOs that provide this type of protection are referred to as Type A RCBOs.

Standard VI RCBOs do not provide this protection, and are referred to as Type AC RCBOs. Havells VD RCBOs have been specifically designed to provide protection against pulsating DC fault currents.

RCBOs are also divided into two categories determined by their response time to an earth fault current, as follows

- General Type - having a trip time <300 ms for fault currents of IDn and <40 ms for fault currents >5 IDn.
- S Type - having a trip time of 150 ms - 500 ms for IDn, and 40 ms - 130 ms for >5 IDn.  
(IDn is the rated residual operating current of the RCBO)

As the name implies, general types are intended for general purpose use. However, S (selective) types are normally used in conjunction with downstream general type RCBOs.

The S type effectively provides discrimination in terms of the response time to earth fault currents for upstream and downstream RCBOs. For example, when two RCBOs are connected in series the first RCBO will often be an S type.



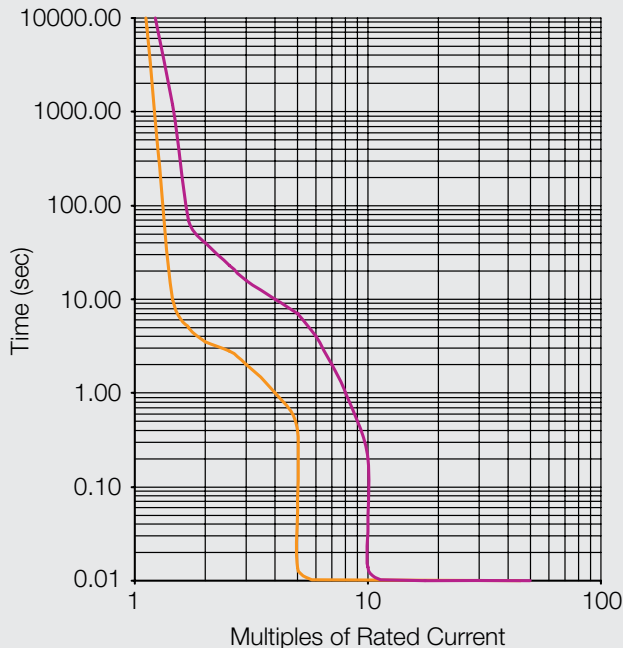

Time Current Characteristics C Curve

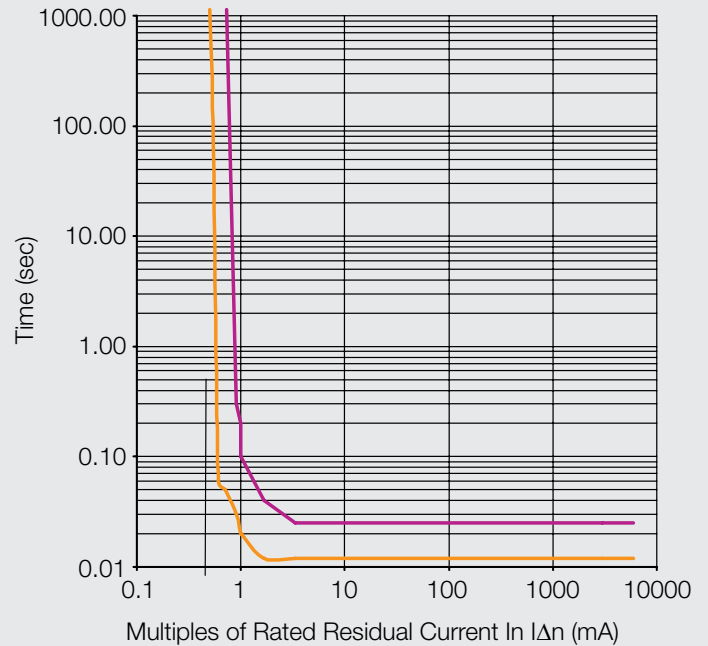

Residual Current Tripping Characteristics (General Type)

Technical Information	Electromechanical 2P RCBOs used as (SPN & DP RCBOs)	Electromechanical 4P RCBOs used as (TPN & FP RCBOs)
Specification Reference	IS 12640 (Part 2) & IEC 61009-1	IS 12640 (Part 2) & IEC 61009-1
Rated Current (In)	32 A, 40 A & 63 A	32 A, 40 A & 63 A
Rated Residual Operating Current (IΔn)	30 mA, 100 mA, 300 mA	30 mA, 100 mA, 300 mA
Instantaneous Tripping Current	'C' curve	'C' curve
Rated Voltage (Un)	240 V~	415 V~
Rated Insulation Voltage (Ui)	690 V	690 V
Rated impulse withstand voltage	4 kV	4 kV
Rated Frequency	50 Hz	50 Hz
No. of Pole	2 Pole	4 Pole
Rated Short Circuit Capacity (Icn)	10 kA	10 kA
Rated Service Short Circuit Capacity (Ics)	7.5 kA	7.5 kA
Rated Residual Making Breaking Capacity (IΔm)	630 A for 63 A (500 A-32 A to 40 A)	630 A for 63 A (500 A-32 A to 40 A)
Operating Characteristics in case of Residual Currents	'A' & 'AC' Type	'A' & 'AC' Type
Nature of Supply	AC, Pulsating DC	AC, Pulsating DC
Method of Mounting	Panel Board Type (DIN Rail)	Panel Board Type (DIN Rail)
Degree of Protection	IP 20	IP 20
Terminals for External Conductors	25 mm <sup>2</sup>	25 mm <sup>2</sup>
Net Weight	0.424 kg	0.740 kg
Ambient Working Temperature	-5 °C to +55 °C	-5 °C to +55 °C
Electrical & Mechanical Endurance	10000/20000 (No. of Operations)	10000/20000 (No. of Operations)
Trip Time	<40 ms	<40 ms
Shock Resistance	40 mm free fall	40 mm free fall
Vibration Resistance	3 G	3 G

# SURGE PROTECTION DEVICES

## TYPE 1+2 AC SURGE PROTECTION DEVICES

These are very compact SPDs which protect both from over voltage surges due to direct lightning strikes (10  $\mu$ s/350  $\mu$ s Waveform) as well as indirect lightning strikes and switching surges (8  $\mu$ s/20  $\mu$ s Waveform). They are an integrated solution, equivalent to an automatically coordinated Type 1 and Type 2 SPDs.

They are used as the first step of protection in incoming power supply panels and areas with exposure to the atmosphere, where installations are usually provided with an external lightning protection system.



### Configuration

SPN, TPN

### Specification

IEC 61643-11: 2011, EN 61643-11: 2012

### Features

- Tested and approved by TUV.
- High Discharge Current (Imax 50 kA (L – N) 70 kA (N – E)).
- Compact Size Integrated Type-1 & Type-2 protection in small module width (Ideal in all reduced-size spaces).
- Better Protection due to reduced Up(Voltage protection level 1.5 kV).
- Both Common & Differential Mode Protection.

### Technical Specification

Standard Compliance	IEC/EN 61643-11
Type / Class	Type 1+2 / Class I+II
Max Continuous Operating AC Voltage Uc	320 V (L - N), 255 V (N - PE)
Lightning Impulse (10/350 microsecond) Iimp	12.5 kA
Nominal Discharge Current (8/20 microsecond) In	20 kA (L - N), 40 kA (N - PE)
Max Discharge Current (8/20 microsecond) Imax	50 kA (L - N), 70 kA (N - PE)
Voltage Protection Level Up	<1.5 kV
Voltage Protection Level 5 kA Up	<1.2 kV
Max Backup Fuse	125 A gL/gG
Temporary Over voltage Characteristics (5 second) Ut	335 V
Residual Current At Uc - Ipe	<100 $\mu$ A
Response Time	<25 ns
Short Circuit Current Rating ISCCR	3 kA
Follow Current extinguishing Capability [N-PE] a.c. I <sub>fi</sub>	100 Arms
Number of Ports	One Port SPD
Location	Indoor
Humidity	5% - 95%
Operating Temperature Range	-40 °C - 80 °C
Operating State/Fault Indication	Green/Red
Cross-section Area	4 mm <sup>2</sup> - 35 mm <sup>2</sup>
For Mounting on	35 mm Din Rail
Enclosure Material	Thermoplastic UL94-V0
Degree of Protection	IP20



### Circuit Diagram

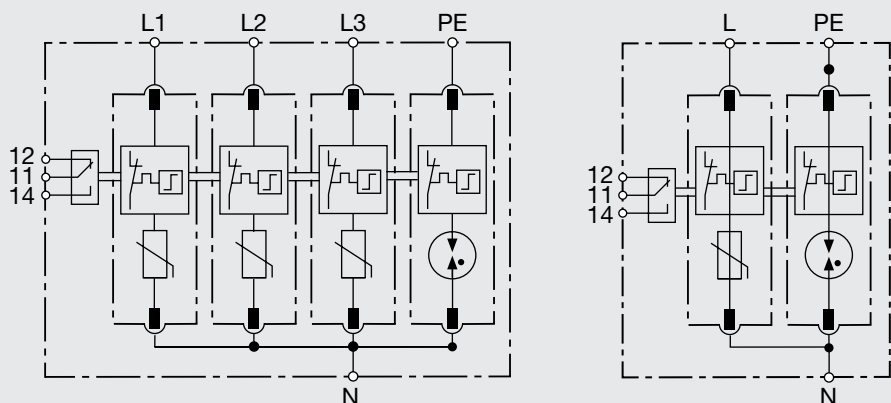

### Dimensions (in mm)

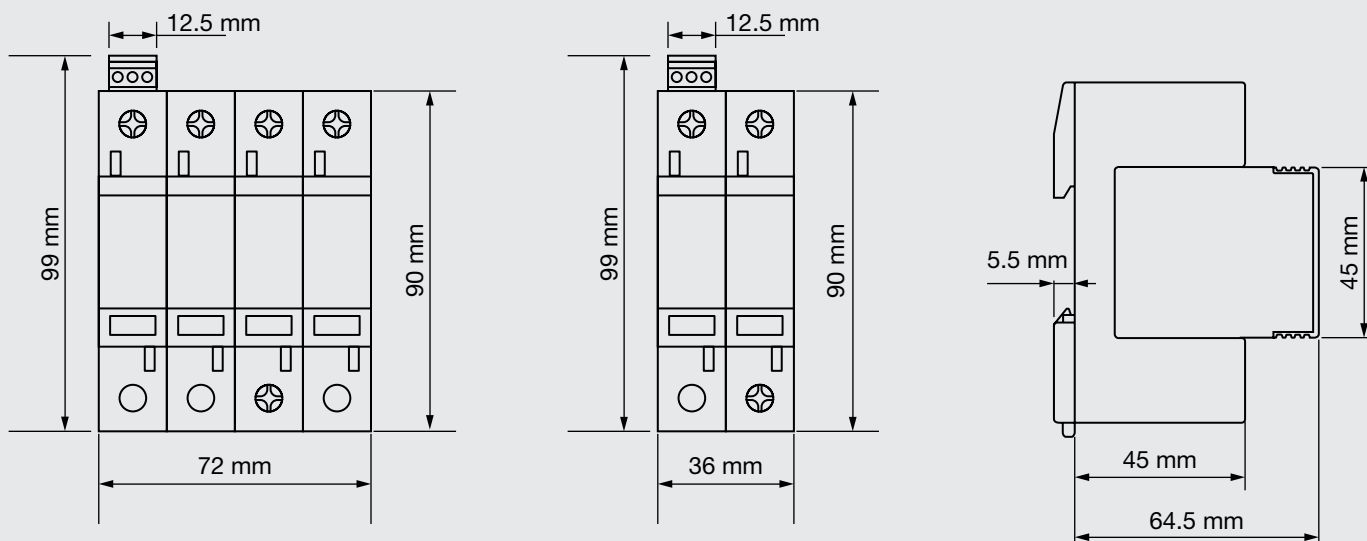

### Connection Diagram

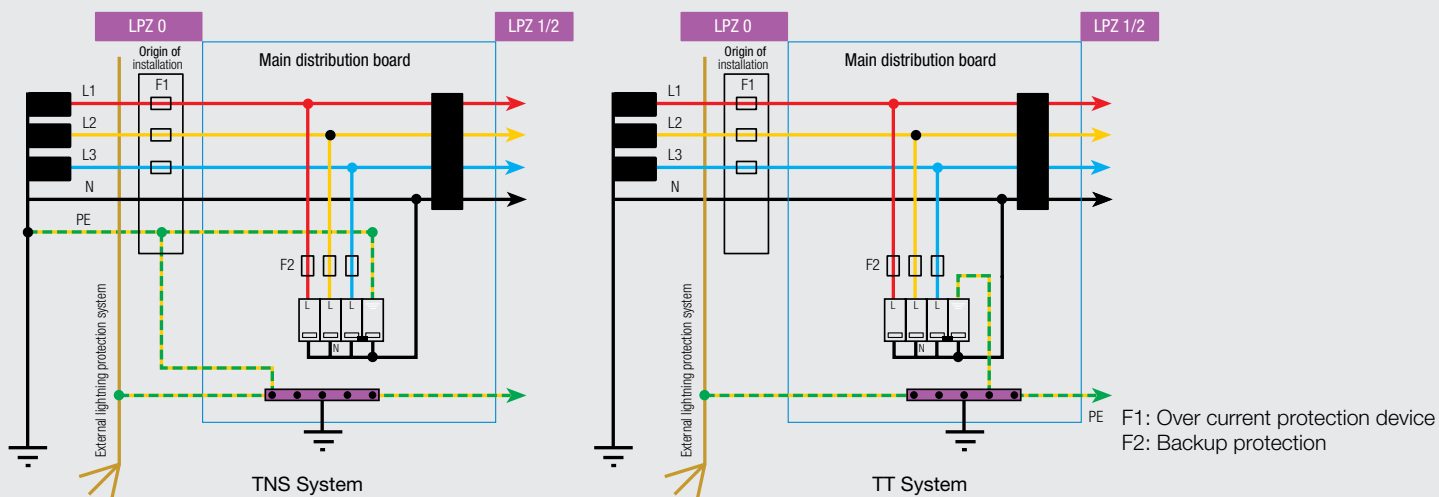

## TYPE 2 AC SURGE PROTECTION DEVICES

Type 2 SPDs provide protection from over-voltage surges due to indirect lightning strikes hitting the building or surrounding area and switching surges (8  $\mu$ s/20  $\mu$ s waveform). They are necessary for second level of protection in applications where Type 1 protectors are installed upstream. They are also used for first stage of protection in residential, commercial or industrial applications not exposed to direct strikes or with no external lightning protection system.

Type 2 SPDs are suitable for use at the entrance of the installation (main DB), in intermediate distribution boards (sub DB) and by the terminal equipment.



### Configuration

SP, SPN, TPN

### Specification

IEC 61643-11: 2011, EN 61643-11: 2012

### Features

- Tested and Approved by TUV.
- Applicable in Two Voltage Rating -  $U_c$  320 V & 275 V.
- Both Common & Differential Mode Protection.
- Better Protection (Voltage protection level Up up to 1.3 kV, suitable for protection of all terminal equipment).

### Technical Specification

Standard Compliance	IEC/EN 61643-11	IEC/EN 61643-11
Type/Class	Type 2/Class II	Type 2/Class II
Max Continuous Operating AC Voltage $U_c$	275 V	320 V
Max Continuous Operating AC Voltage [N-PE] $U_c$	255 V	255 V
Nominal Discharge Current (8/20 $\mu$ s) $I_n$	20 kA	20 kA
Max Discharge Current (8/20 $\mu$ s) $I_{max}$	40 kA	40 kA
Voltage Protection Level Up	<1.3 kV	<1.5 kV
Voltage Protection Level 5 kA Up	<1 kV	<1.2 kV
Voltage Protection Level [N-PE] Up	<1.5 kV	<1.5 kV
Residual Current At $U_c$ - $I_{pe}$	<100 $\mu$ A	<100 $\mu$ A
Short Circuit Current Rating ISCCR	3 kA	3 kA
Follow Current extinguishing Capability [N-PE] a.c. $I_{fi}$	100 Arms	100 Arms
Max Backup Fuse	125 A gL/gG	125 A gL/gG
Response Time	<25 ns	<25 ns
Response Time [N-PE]	<100 ns	<100 ns
Operating Temperature Range	-40 $^{\circ}$ C - 80 $^{\circ}$ C	-40 $^{\circ}$ C - 80 $^{\circ}$ C
Temporary Overvoltage [L-N] ( $U_1$ )	335 V/5 s - Withstand	335 V/5 s - Withstand
	440 V/120 min - Safe failure	440 V/120 min - Safe failure
Temporary Overvoltage [N-PE] ( $U_1$ )	1200 V/200 ms - Withstand	1200 V/200 ms - Withstand
Operating State/Fault Indication	Green/Red	Green/Red
Cross-section Area	4 mm <sup>2</sup> - 35 mm <sup>2</sup>	4 mm <sup>2</sup> - 35 mm <sup>2</sup>
For Mounting on	35 mm Din Rail	35 mm Din Rail
Enclosure Material	Thermoplastic UL94-V0	Thermoplastic UL94-V0
Degree of Protection	IP 20	IP 20



**Circuit Diagram**

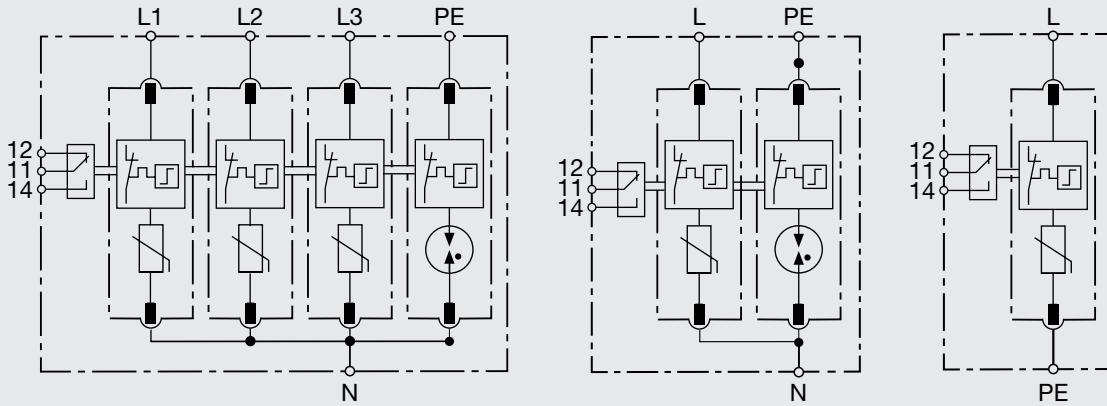

**Dimensions (in mm)**

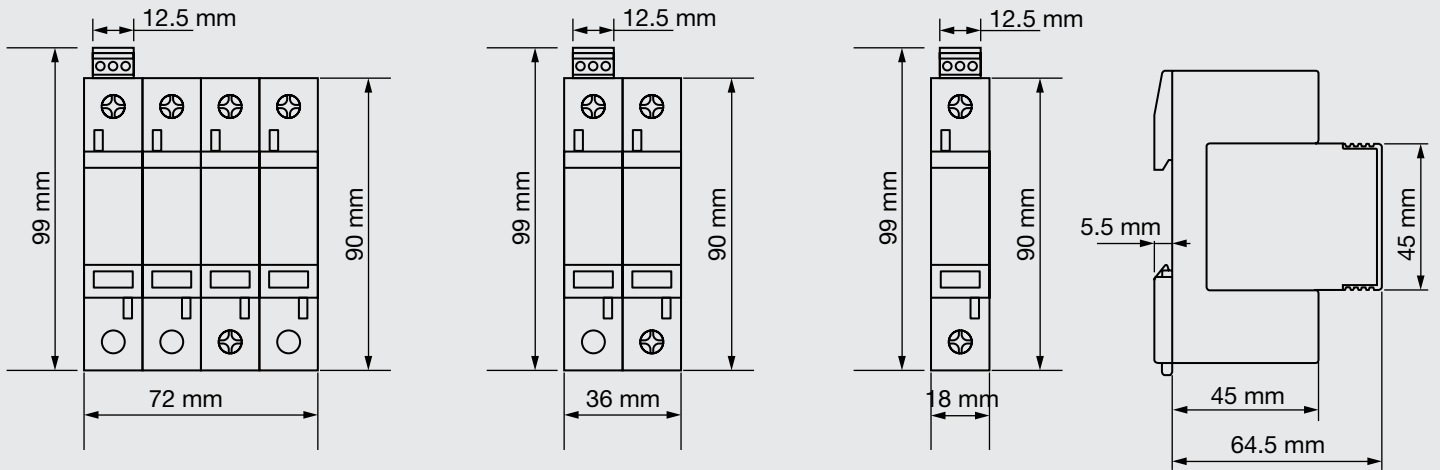

**Connection Diagram**

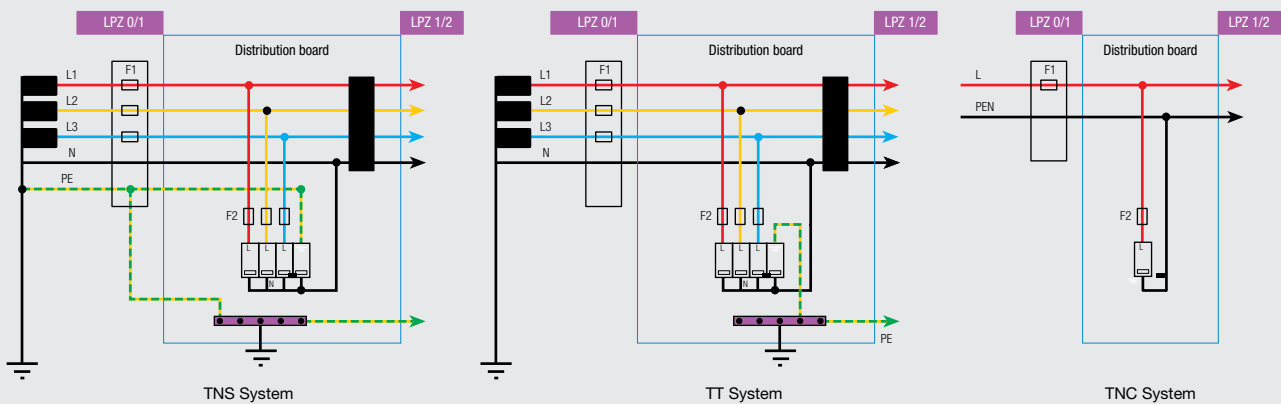

F1: Over current protection device  
F2: Backup protection

## SURGE PROTECTION ADAPTOR TYPE 3

Havells Type 3 SPD is extended version for type 2 SPD to reach unit home appliances (eg. Home Entertainment System, Home Appliances, Computer & Accessories and Medical Electronic Devices...etc) level surge protection.

These SPDs have a low discharge capacity. It is installed in parallel with the sensitive loads. Type 3 SPD is characterized by a combination of voltage waves (1.2  $\mu$ s/50  $\mu$ s) and current waves (8  $\mu$ s/20  $\mu$ s), to ensure a very low protection level voltage value.



### Range

Type 3 Surge protection Adaptor

### Specification

IEC 61643-11:2011

### Features

- Havells Type 3 SPD is extended version for Type 2 SPD to provide socket level surge protection
- Both Common & Differential Mode Protection.
- Better Protection (Voltage protection,  $U_p < 1.5$  kV, suitable for protection of all terminal equipment).

### Technical Specification



Standard Compliance	IEC 61643-11
Type/Class	Type 2 + 3/ Class II + III (Socket module)
Rated Current	6 A
Nominal a.c. Voltage, $U_n$	230 V ac
Max Continuous Operating Ac Voltage, $U_c$	320 V ac
Nominal Discharge Current, $I_n$	5 kA
Max Discharge Current, $I_{max}$	10 kA
Voltage Protection Level, $U_p$	< 1.5 kV
Open Circuit Voltage, $U_{oc}$	6 kV
Operating Temperature Range	-10 °C to +60 °C
Operating State/ Fault Indication	<ul style="list-style-type: none"> <li>Green : Healthy</li> <li>Red : Line fault</li> <li>Blank: Neutral fault</li> </ul>
Enclosure Material	Thermoplastic
Degree of protection	IP20

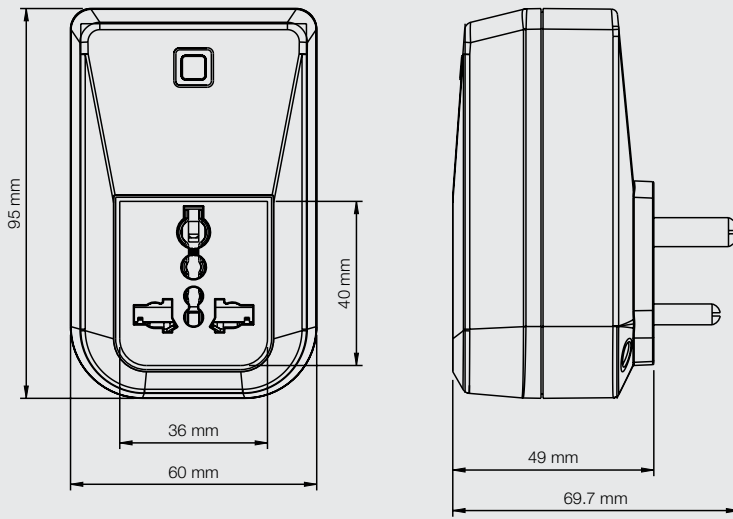

**Dimensions (in mm)**

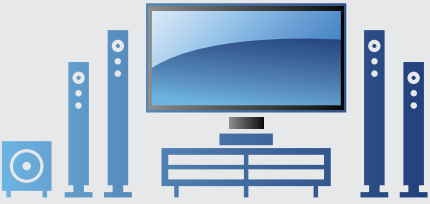

**Application Area**

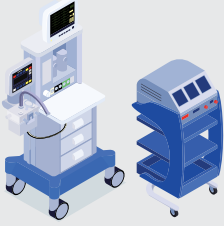
	<p>Installed Inside home for sensing surges with low discharge capacity.</p>
 <p>Home Entertainment System</p>	 <p>Home Appliances</p>
 <p>Computer &amp; Accessories</p>	 <p>Medical Electronic Devices</p>

## TYPE 1+2 PHOTOVOLTAIC SURGE PROTECTION DEVICES

For photovoltaic systems, often located in isolated and exposed locations and with a generally large surface area, the threat of lightning is quite common. The risk is multiple: direct effect (lightning strike on the panels) and indirect (surge on cells, solar chargers, inverters), or on other lines (data). When the PV system is located on industrial sites, the risk of switching overvoltage surges must also be taken into account. For this reason, and given the high value of the components and the high cost of any down time, SPDs are highly recommended.

The Type 1+2 PV SPD range allows the DC side of each PV installation to be effectively protected against over voltages, both due to direct lightning strikes (10  $\mu$ s/350  $\mu$ s discharge current wave) as well as indirect lightning strike and switching surges (8  $\mu$ s/20  $\mu$ s discharge current wave).



### Range

Type 1+2 Photovoltaic Surge Protection Devices

### Specification

EN 50539-11: 2013

### Features

- Tested and Approved by TUV.
- High Operating Voltage (Uc<sub>pv</sub> 1200 V dc).
- High Discharge Current:  
I<sub>max</sub> 60 kA for 4-module SPD (I<sub>imp</sub> 12.5 kA)  
I<sub>max</sub> 40 kA for 3-module SPD (I<sub>imp</sub> 6 kA)
- Remove Monitoring Option.

### Technical Specification

	Type 1+2 (12.5 kA)	Type 1+2 (6 kA)
Standard Compliance	EN 50539-11	EN 50539-11
Type	Type 1+2	Type 1+2
Max Continuous Operating DC Voltage U <sub>cpv</sub>	1200 V dc	1200 V dc
Lightning Impulse (10/350 microsecond) I <sub>imp</sub>	12.5 kA	6 kA
Nominal Discharge Current (8/20 microsecond) I <sub>n</sub>	20 kA	20 kA
Max Discharge Current (8/20 microsecond) I <sub>max</sub>	60 kA	40 kA
Voltage Protection Level U <sub>p</sub>	<4 kV	<4 kV
Short Circuit Current with Stand I <sub>scpv</sub>	1000 A	1000 A
Leakage Current	<100 $\mu$ A	<100 $\mu$ A
Response Time	<25 ns	<25 ns
Operating State/Fault Indication	Green/No Light	Green/Red
Thermal Disconnecter	Internal	Internal
Fuses	Without	Without
Operating Temperature Range	-40 °C - 80 °C	-40 °C - 80 °C
Cross-section Area	4 sq. mm - 35 sq. mm	4 sq. mm - 35 sq. mm
For Mounting on	35 mm Din Rail	35 mm Din Rail
Enclosure Material	Thermoplastic UL94-V0	Thermoplastic UL94-V0
Degree of protection	IP20	IP20



### Circuit Diagram

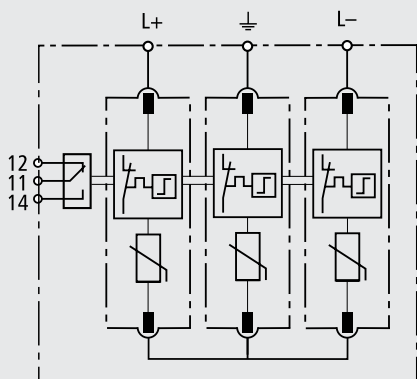

Type 1+2 SPD (6kA)

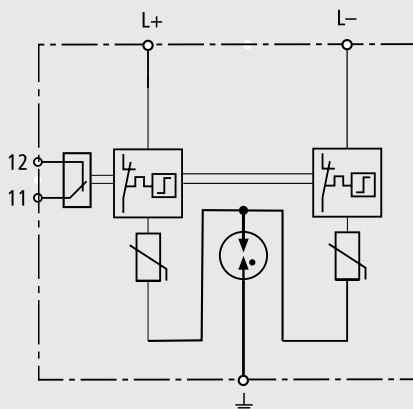

Type 1+2 SPD (12.5kA)

### Dimensions (in mm)

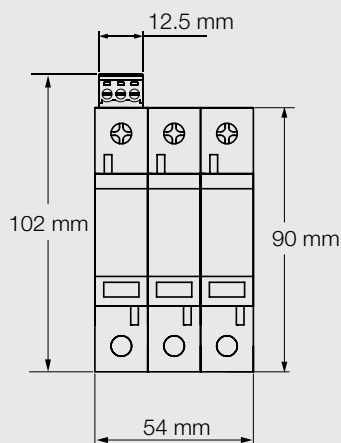

Type 1+2 SPD (6 kA)

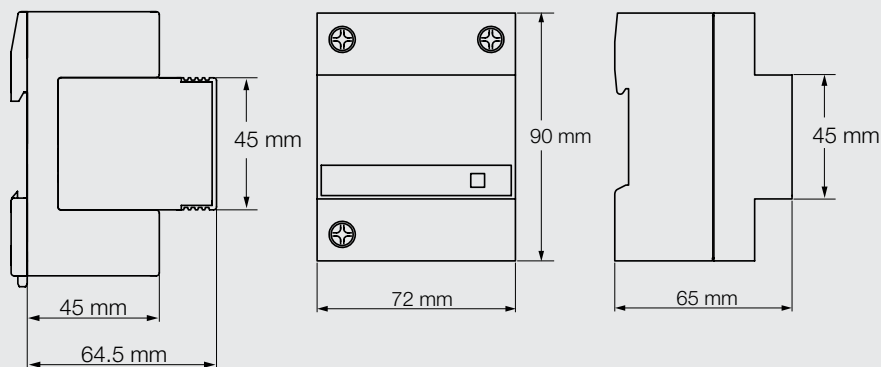

Type 1+2 SPD (12.5 kA)

### Connection Diagram

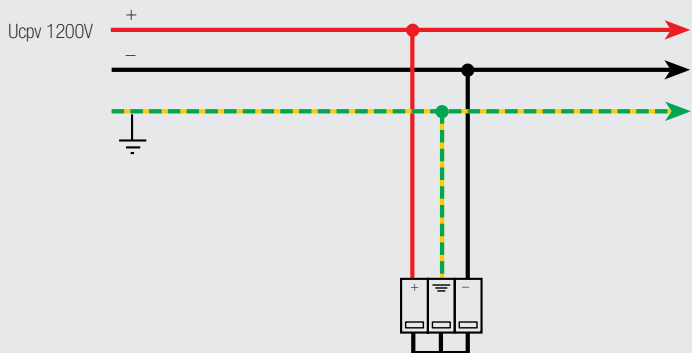

Type 1+2 SPD (6kA)

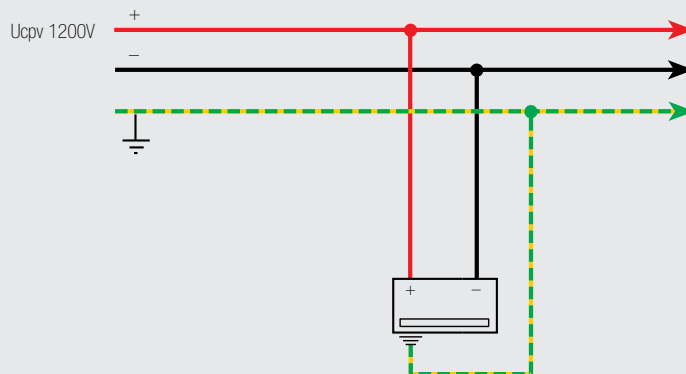

Type 1+2 SPD (12.5kA)

## TYPE 2 PHOTOVOLTAIC SURGE PROTECTION DEVICES

The Type 2 PV SPD range allows the DC side of each PV installation to be effectively protected against over voltages due to indirect lightning strikes and switching surges (8  $\mu$ s/20  $\mu$ s discharge current wave).

They are suitable for all PV applications: large-scale, rooftop and self-consumption (off-grid) DC installations.



### Range

Type 2 Photovoltaic Surge Protection Devices

### Specification

EN 50539-11: 2013

### Features

- Tested and Approved by TUV.
- High Operating Voltage (Uc<sub>pv</sub> 1200 V dc).
- High Discharge Current:  
Maximum discharge current 40 kA.
- Both Common and Differential Mode Protection.
- Remote Monitoring Option.

### Technical Specification

Standard Compliance	EN 50539-11
Type	Type 2
Max Continuous Operating DC Voltage U <sub>cpv</sub>	1200 V dc
Nominal Discharge Current (8/20 microsecond) I <sub>n</sub>	20 kA
Max Discharge Current (8/20 microsecond) I <sub>max</sub>	40 kA
Voltage Protection Level U <sub>p</sub>	<4 kV
Short Circuit Current Withstand I <sub>scpv</sub>	1000 A
Leakage Current	<100 $\mu$ A
Response Time	<25 ns
Operating Temperature Range	-40 °C - 80 °C
Humidity	5% - 95%
Installation	Indoor
Thermal Disconnector	Internal
Fuses	Without
Operating State/Fault Indication	Green/Red
Cross-section Area	4 sq. mm - 35 sq. mm
For Mounting on	35 mm Din Rail
Enclosure Material	Thermoplastic UL94-V0
Degree of protection	IP20
Degree of protection	IP20



**Circuit Diagram**

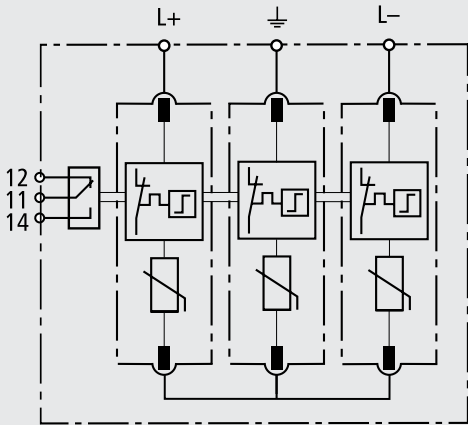

**Dimensions (in mm)**

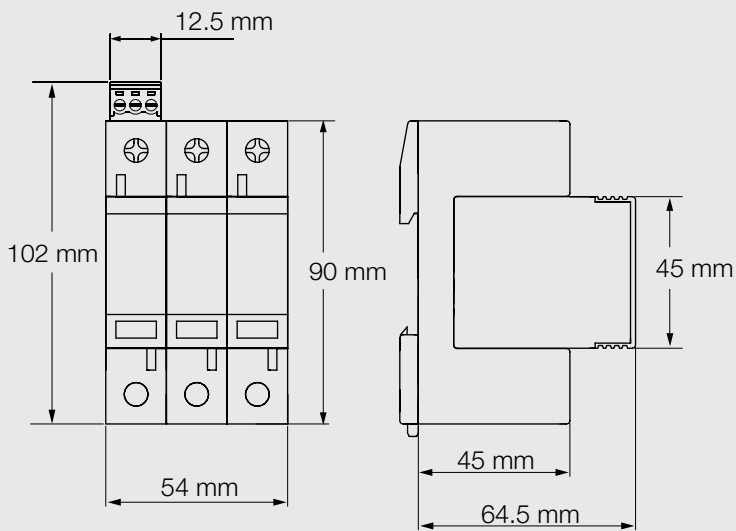

**Connection Diagram**

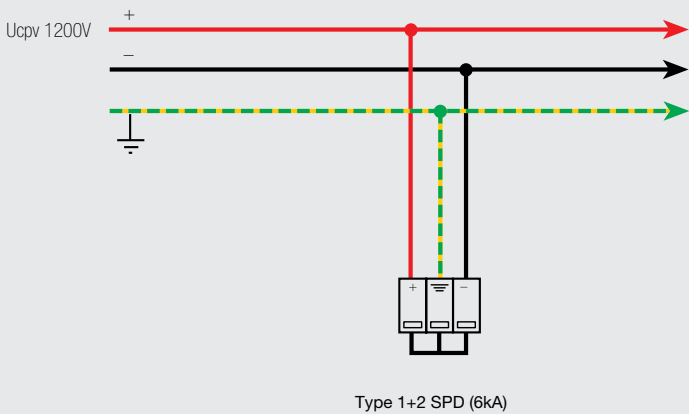

## Type 2 DC 600 V SURGE PROTECTION DEVICES

The Type 2 PV SPD range allows the DC side of each PV installation to be effectively protected against over voltages due to indirect lightning strikes and switching surges (8  $\mu$ s/20  $\mu$ s discharge current wave).



### Range

Type 2 DC 600 V Surge Protection Devices

### Specification

EN 50539-11: 2013

### Features

- Tested and Approved by TUV.
- High Operating Voltage (Ucpv 600 V dc).
- High Discharge Current:  
Maximum discharge current 40 kA.
- Both Common and Differential Mode Protection.
- Remote Monitoring Option.

### Technical Specification

SPD Classification According to EN61643-11		Type 2
SPD Classification According to EN61643-11		Class II
Max. Continuous Operating dc Voltage	Ucpv	$\leq 600$ V
Nominal Discharge Current (8/20 $\mu$ s)	In	20 kA
Max. Discharge Current (8/20 $\mu$ s)	Imax	40 kA
Voltage Protection Level	Up	$\leq 2.6$ kV
Response Time	tA	$\leq 25$ ns
Operating Temperature Range	Tu	-40 °C - 80 °C
Operating state / fault indication		green / red
Cross-section area (Minimum)		4 mm <sup>2</sup>
Cross-section area (Maximum)		35 mm <sup>2</sup>
For Mounting on		35 mm Din Rail
Enclosure Material		Thermoplastic UL94-V0
Degree of Protection		IP20



## Circuit Diagram

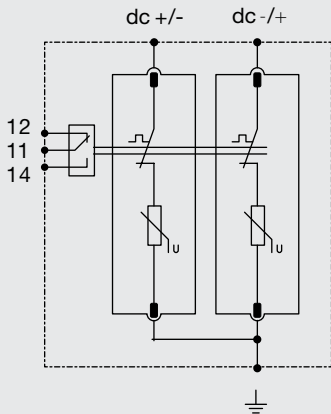

## Dimensions (in mm)

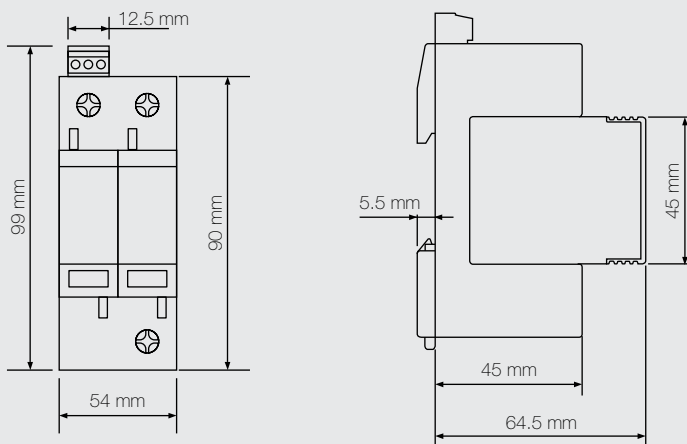

## Wiring Diagram

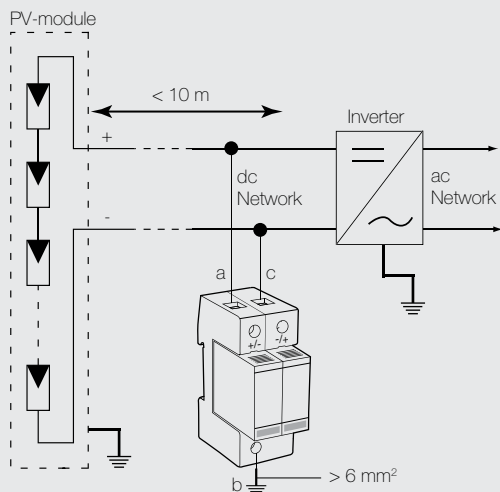

**Note:**

- In case the distance of SPD from the equipment to be protected is more than 10 m, additional SPD closer to the equipment must be installed.
- The length of connecting cables (a, b, c) of SPD should be as short as possible.

# DIGITAL WEEKLY TIME SWITCH

## Application

It involves controlling loads such as heating, lighting and ventilation systems of residential or commercial places.

In this example the digital weekly time switch controls the operation of a lighting system in a workplace. It offers flexibility to program ON/OFF switching times based on the days of the week. So the lighting system can be set ON from 8:00 h to 17:00 h from MON to FRI and it will remain in the OFF condition on the weekends.

Technical Specifications	
Supply terminals	A1-A2
Operating Voltage	220 V ac-240 V ac
Program Functions	ON/OFF
Number of programs	52
Number of Channels	1
Power Reserve	3 years
Max. Switching Capacity	2300 W
Frequency	50 Hz/60 Hz
Power consumption	1 W
Program	Weekly, daily
Data readout	LCD display
Supply voltage tolerance	±10%
Operating modes	Manual, automatic, holiday
Summer/winter time	off, automatic changeover
Mechanical life	10 <sup>6</sup>
Electrical life	10 <sup>5</sup>
Rated insulation voltage	250 V
Wire size	1 mm <sup>2</sup> - 4 mm <sup>2</sup>
Tightening torque	0.5 Nm
Mounting	DIN rail mounting
Dimensions	90 mm × 36 mm × 65 mm
Standard	IEC 60730-1/IEC 60730-2-7



**Wiring Diagram - Single Load**

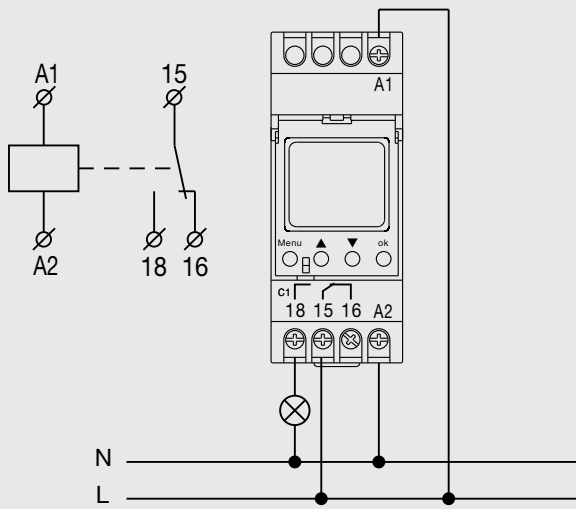

**Dimensions (in mm)**

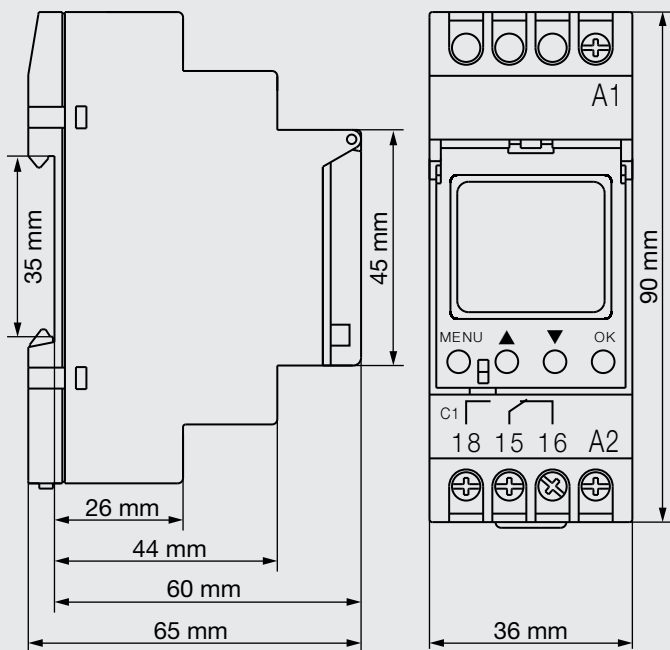

# ASTRONOMICAL + DIGITAL TIME SWITCH

## Application

Astronomical digital time switch automatically switches lighting circuits according to the sunrise and sunset time. Programming is based on the latitude as well as the longitude and time zone of the geographical area where the time switch will be installed. In this case the street light will be switched ON at the time of sunset till sunrise.

Additionally it offers flexibility to program ON/OFF switching times based on the days of the week.

Technical Specifications	
Operating Voltage	220 V~ - 230 V~
Number of Channel	1
Power Reserve	3 years
Frequency	50 Hz/60 Hz
Power consumption	1 W
Program	Weekly, annual, astronomical
Data readout	LCD display with backlight
No. of programs	100
Mechanical life	10 <sup>6</sup>
Electrical life	10 <sup>5</sup>
Supply terminals	A1-A2
Supply voltage tolerance	±10%
Operating modes	Manual, automatic, holiday, random
Summer/winter time	off, automatic changeover
Rated insulation voltage	250 V
Wire size	1 mm <sup>2</sup> - 4 mm <sup>2</sup>
Tightening torque	0.5 Nm
Mounting	Din rail mounting
Dimensions	90 mm × 36 mm × 65 mm
Standard	IEC 60730-1/IEC 60730-2-7



### Wiring Diagrams Single Load

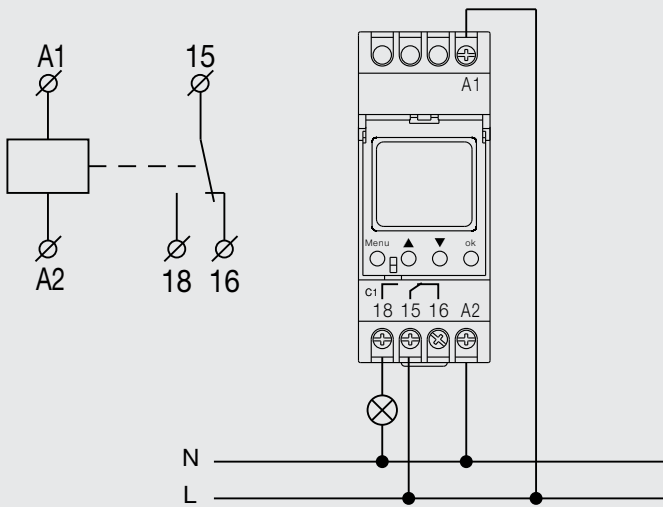

### Dimensions (in mm)

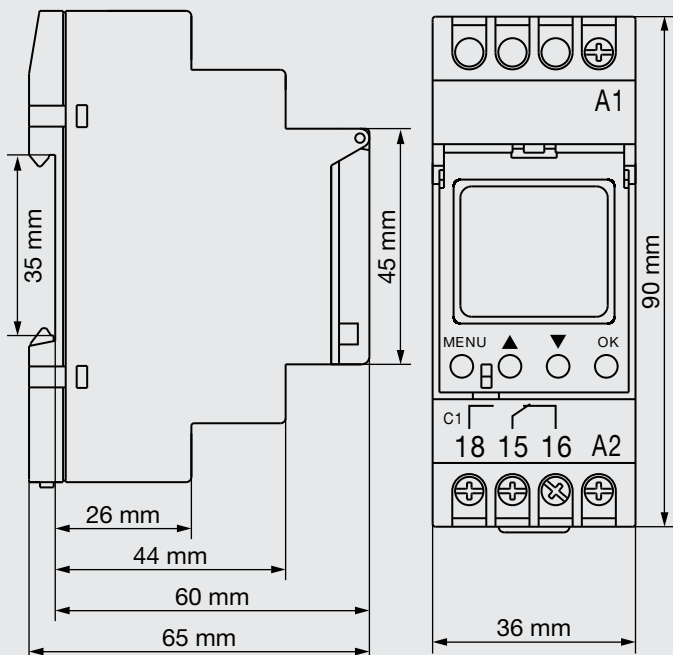

## 24 HOURS ANALOG TIME SWITCH

### Application

The 24 Hour Analog Time Switch is used in pre-programmed switching of:

- Lighting (car parking, advertising sign boards)
- Heating equipment (home & work environment, water heating, etc.)
- Motors for pumps & fans

The lighting in parking areas can be switched On/OFF using the 24 hour analog time switch. This can be achieved by setting the program in advance. The starting time has to be scheduled on the dial which is done by pulling a segment on the desired time.

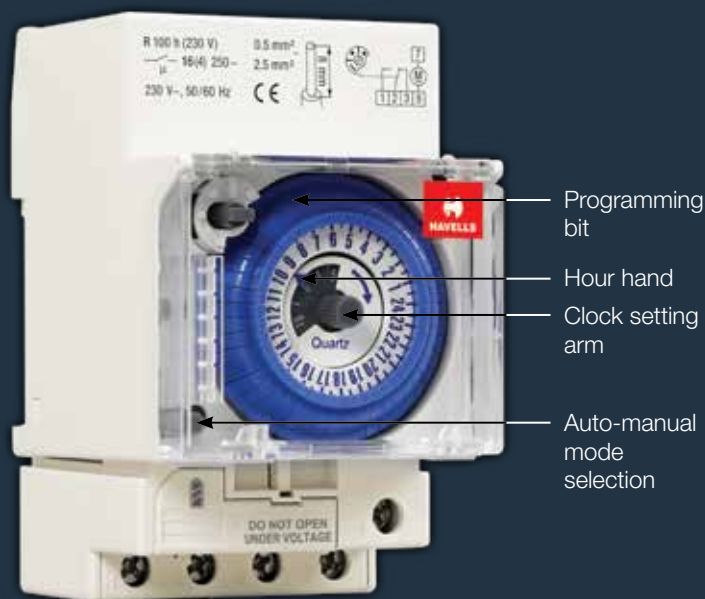

### Technical Specifications

Operating Voltage	220 V ac - 240 V ac
Rated Frequency	50 Hz/60 Hz
Width	54.5 mm
Weight	0.2 kg
Installation Type	DIN Rail
Type of Contact	Changeover Contact
Program Functions	ON/OFF
Number of Memory Locations	48
Power Reserve	100 h
Max. Switching Capacity at 250 V ac, cosφ = 1	16 A
Max. Switching Capacity at 250 V ac, cosφ = 0.6	4 A
Shortest Switching Time	15 minutes / 30 minutes
Mechanical Life	10 <sup>7</sup>
Electrical Life	10 <sup>5</sup>
Time Accuracy	≤1 s/day Quartz
Power Consumption	5 VA
Degree of Protection	IP 20
Ambient Temperature	-10 °C to +55 °C



**Wiring Diagrams -  
15 minutes**

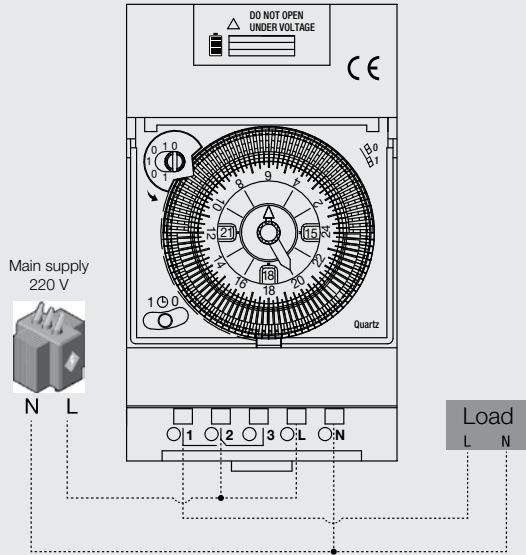

**Wiring Diagrams -  
30 minutes**

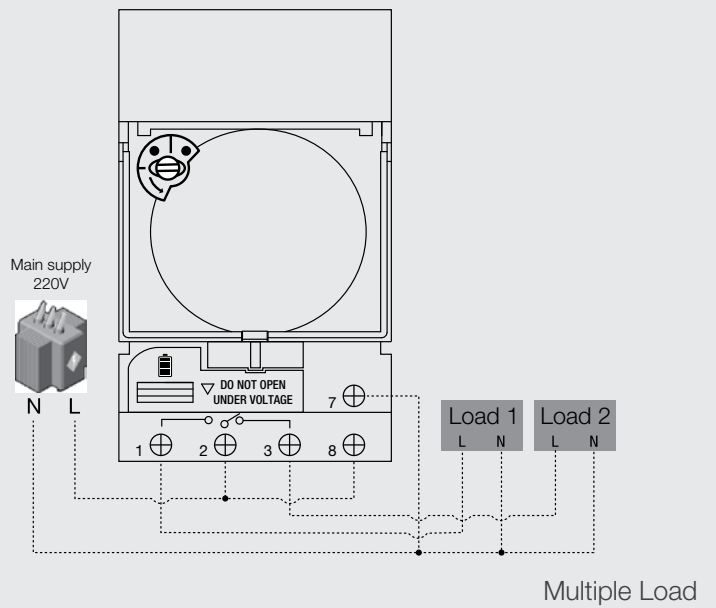
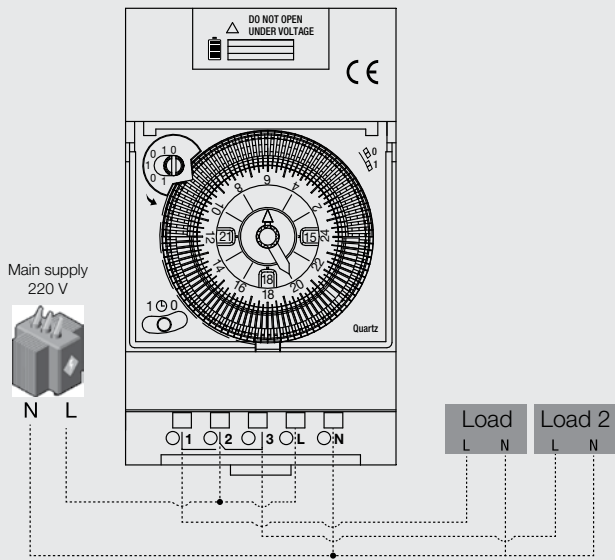
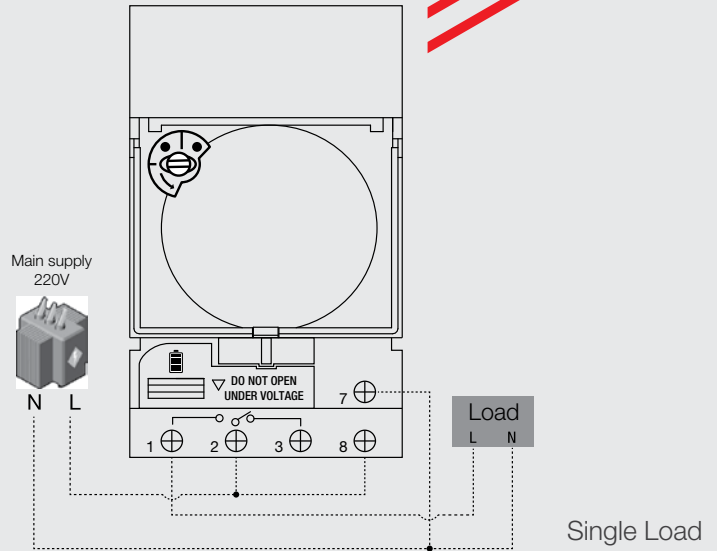

**Dimensions (in mm) - 15 minutes**

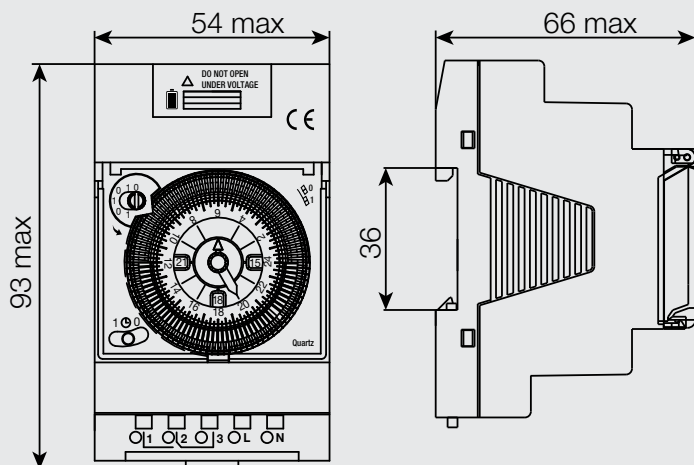

**Dimensions (in mm) - 30 minutes**

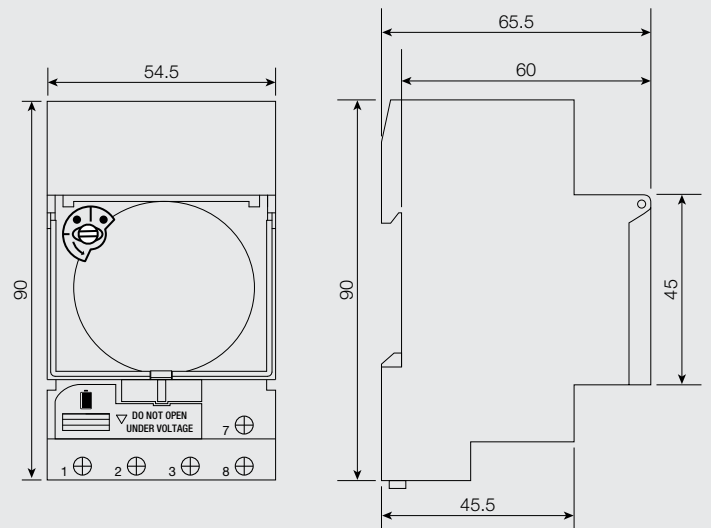

# ISOLATOR

Technical Specification	
Reference Standard	IS/IEC 60947-3
No. of Poles	1P, 2P, 3P, 4P
Utilization Category	AC 22 A
Rated Current (In)	40 A, 63 A
Rated Voltage (Ue)	240 V ac/415 V ac
Rated Frequency	50 Hz
Rated Insulation Voltage (Ui)	690 V
Rated Impulse Voltage (Uimp)	4 kV
Dielectric Strength	2.5 kV
Electrical / Mechanical Endurance (no. of operations) minimum	10000/20000
Operating Temperature	-5 °C to +55 °C
Humidity	95% RH
Terminal Capacity (max)	35 mm <sup>2</sup> (up to 63 A)
Tightening Torque	2 N-m
Vibration	3 g
Shock Resistance	40 mm free fall
Protection Class	IP 20
Positive Contact Indication	Yes, Through Flag Indication (Red-ON, Green-OFF)
Net Weight / Pole in kg	90 g
Dimensions (H x D x W) / Pole in mm	87.5 mm x 62 mm x 17.7 mm
Mounting	Clip on DIN Rail (35 mm x 7.5 mm)
Installation Position	Vertical / Horizontal
Case & Cover	Moulded, flame retardant thermoplastic material
Bus bar Connections Top Side	Pin Type
Bus bar Connections Bottom Side	Pin / Fork Type

## Dimensions (in mm)

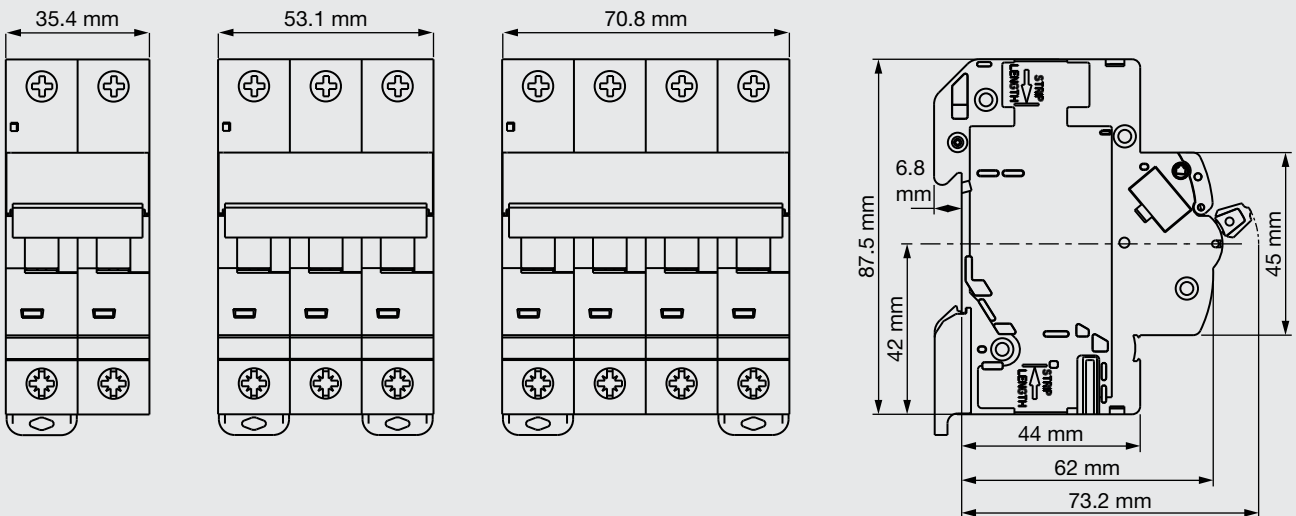

## HIGHER CURRENT ISOLATOR (80 A-125 A)

Technical Specification	
Reference Standard	IS/IEC 60947-3
No. of Poles	2P, 3P, 4P
Utilization Category	AC 22 A
Rated Current (In)	80 A, 100 A, 125 A
Rated Voltage (Ue)	240 V ac/415 V ac
Rated Frequency	50 Hz
Rated Insulation Voltage (Ui)	690 V
Rated Impulse Voltage (Uimp)	4 kV
Dielectric Strength	2.5 kV
Electrical / Mechanical Endurance (no. of operations) minimum	5000/20000
Operating Temperature	-5 °C to +55 °C
Humidity	95% RH
Terminal Capacity (max)	50 mm <sup>2</sup>
Tightening Torque	2.5 N-m
Vibration g	3 g
Shock Resistance	40 mm free fall
Protection Class	IP 20
Positive Contact Indication	Yes, Through Flag Indication (Red-ON, Green-OFF)
Net Weight in g	158 g (for 2P), 237 g (for 3P), 316 g (for 4P)
Dimensions (H x D x W) in mm	87.5 mm x 62 mm x 35.4 mm (for 2P), 87.5 mm x 62 mm x 53.1 mm (for 3P), 87.5 mm x 62 mm x 70.8 mm (for 4P)
Mounting	Clip on DIN Rail (35 mm x 7.5 mm)
Installation Position	Vertical / Horizontal
Case & Cover	Moulded, flame retardant thermoplastic material
Bus bar Connections Top Side	Pin / Fork Type
Bus bar Connections Bottom Side	Pin / Fork Type

### Dimensions (in mm)

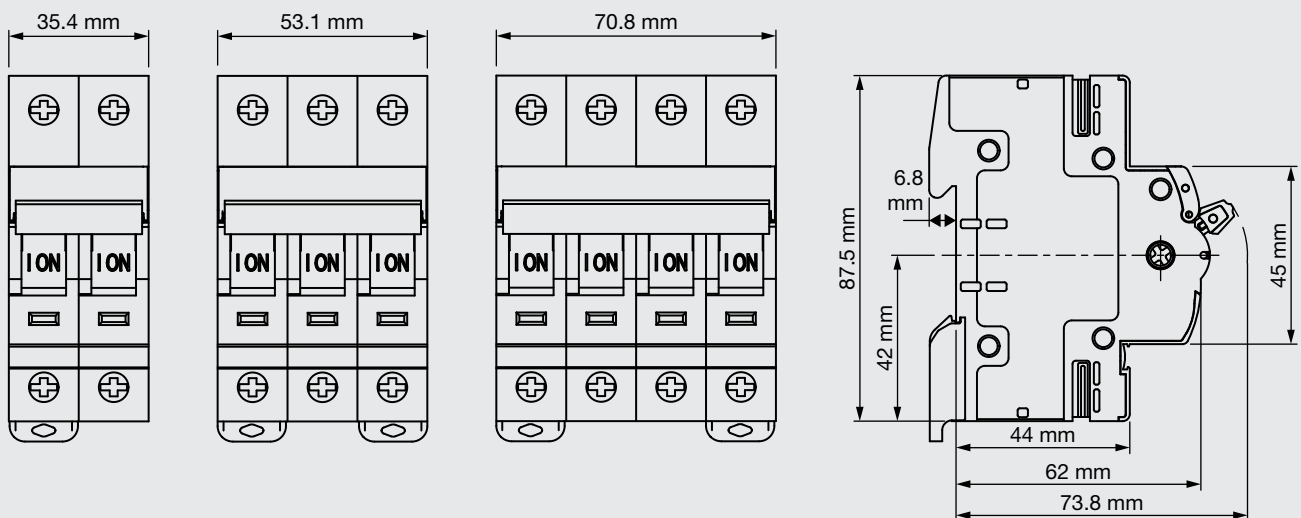

## AUTOMATIC SOURCE CHANGEOVER DEVICES

### ACCL - SPN

Features	Havells 3 Module SPN ACCL		Other Competitor Products	
OFF load Changeover	✓	ON Load Changeover	✓	ON Load Changeover
Zero Crossing Detection Technology	✗	Can takes place on peak of sinusoidal AC supply which may result in harsh effect of Transient surges and decrease in life of relay.	✗	Can takes place on peak of sinusoidal AC supply which may result in harsh effect of Transient surges and decrease in life of relay.
Advance Neutral	✗	Neutral makes and break with phase.	✗	Neutral makes and break with phase.
Terminal for external conductors	✓	Indirect pressure type terminals	✗	Direct Pressure type
Bottom Wiring	✓	Yes	✗	No
Staggered Wiring	✓	Provides better isolation between phase and neutral	✗	Not Available
Conditional Short-circuit current	✓	3 kA	✗	Not Mentioned
Eco friendly housing	✓	Thermoplastic, PA6 FR grade	✓	Thermoplastic
Local reset facility	✗	Not Provided	✗	Not Provided
Overload indication facility	✓	Generator LED blinks to show overload condition	✗	Not Provided
Standard conformity	✓	IEC 60947 – 6-1	✗	No marking on product
Rated impulse voltage	✓	2.5 kV	✗	Not mentioned
Operational voltage	✓	150 V ac-270 V ac	✓	180 V ac-240 V ac
Pre trip indication in overload condition	✗	Not Provided	✗	Not Provided
Compact design	✓	87.5 mm × 53.1 mm × 63 mm	✓	108 mm × 72 mm × 68 mm



Technical Specification	SPN ACCL 3 Module
Standard Conformity	IEC 60947-6-1
No. of Poles	1P+N
Rated current (In)	30 A on mains, 1.5 A - 20 A on generator
Rated voltage (Ue)	240 V~
Rated frequency	50 Hz
Rated insulation voltage	500 V
Transfer time	8 s-12 s
Restoring time	0 s-2 s
Utilization category	AC 31 A
Class of equipment	PC
Environment	B
Indication	Mains, Generator, Overload
Ambient temp.	-5 °C to +55 °C
Electrical life (No. of operations)	6000
Rated impulse voltage	2.5 kV
Duty	Uninterrupted
Pollution degree	2
Conditional short circuit current (I <sub>nc</sub> )	3 kA
Protection class	IP20
Mounting	standard mounting RAIL (35 mm x 7.5 mm)
Mounting position	Vertical /Horizontal
Terminal Capacity	10 mm <sup>2</sup>
Weight	350 g

## Dimensions (in mm)

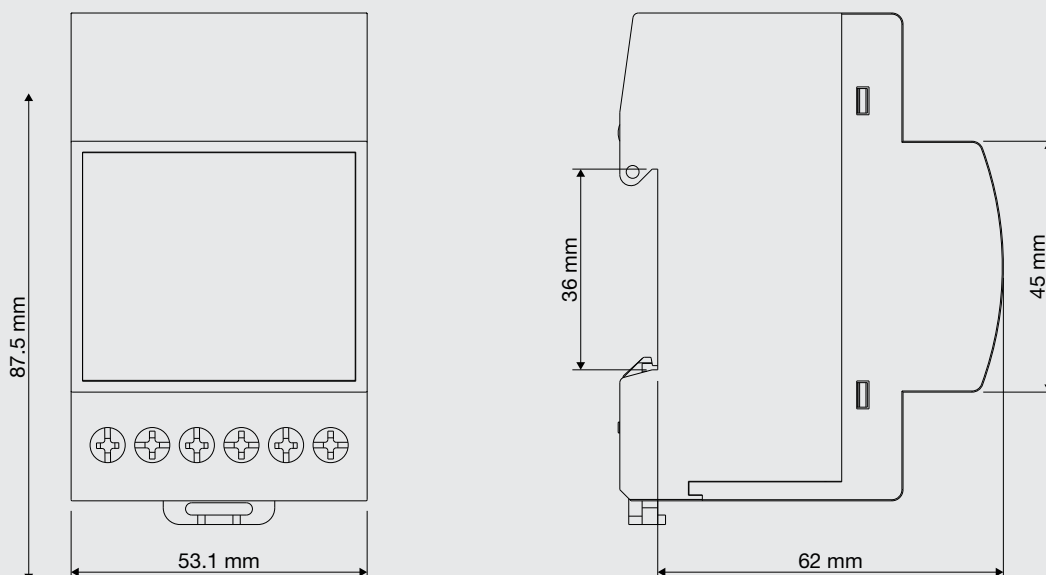

## ACCL - TPN

Parameters	TPN ACCL (TPN ACCL in Sheet metal)	
Automatic Changeover	✓	
Overload Protection on Gen side	✓	
Range	Mains	Gen
	TPN 80 A	SPN 20 A-63 A
	TPN 80 A	TPN 20 A-63 A
Dimensions	(260 mm x 243 mm x 115 mm) for 40 A TPN ACCL (260 mm x 243 mm x 150 mm) for 63 A TPN ACCL (383 mm x 333 mm x 150 mm) for 80 A TPN ACCL	
Mode selection	✓	
Local reset facility	Required, as ACCL goes into the sleep mode after 5 cycles of interruption	
Indications	Mains, Gen, Load, Overload on R, Y and B phase, Auto/manual mode through membrane keypad	
Mounting	Surface mounted	
Housing	Sheet metal	

Technical Specification	TPN ACCL
Standard Conformity	IEC 60947-6-1
No. of Poles	3P+N
Rated current (In)	40 A/63 A/80 A on mains, 10 A-63 A on gen
Rated voltage (Ue)	415 V~/220 V~
Rated frequency	50 Hz
Transfer time	8 s-12 s
Restoring time	2 s-4 s
Utilization category	AC 31 A
Class of equipment	PC
Environment	B
Indication	Mains, Generator, Load, Overload (R,Y,B), mode of operation (auto/manual)
Ambient temp.	-5 °C to +55 °C
Electrical life (No. of operations)	6000
Rated impulse voltage	6 kV
Duty	Uninterrupted
Pollution degree	2
Conditional short circuit current (I <sub>nc</sub> )	5 kA
Protection class	IP 20
Mounting	surface mounting
Mounting position	Vertical
Terminal Capacity	16 mm <sup>2</sup> /35 mm <sup>2</sup>
Weight	4.5 kg/9.4 kg



**Dimensions (in mm)**

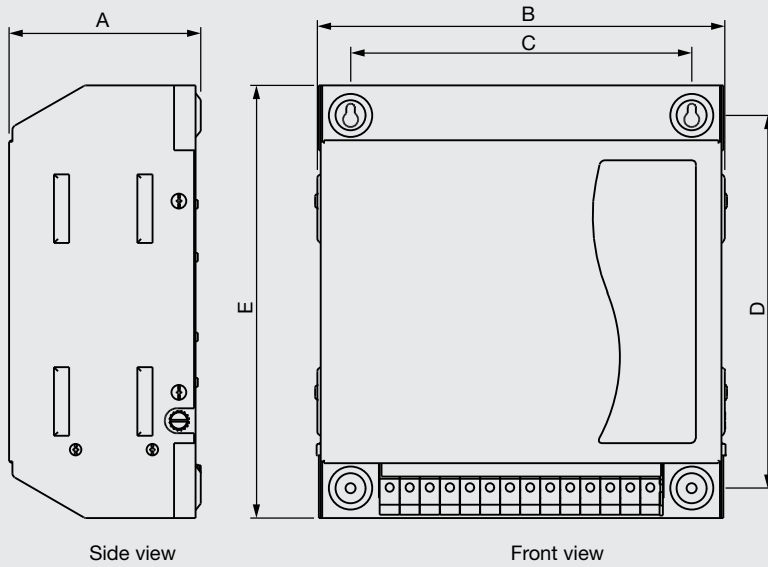

Rating	A	B	C	D	E
40 A TPN ACCL	115	243	205	224	260
63 A TPN ACCL	150	243	205	224	260
80 A TPN ACCL	150	333	293	337	383

# MODULAR CONTACTOR

## Principle Of Operation

Contactors are electromechanically actuated switches comprising of main circuit and control circuit. They are used to control single or multi-phase high power loads in main circuit, via a very low powered control circuit.

A contactor's control circuit basically comprises of electromagnet and coil assembly. There are two E-shaped electromagnets - Fixed Core & Moving Core, and a coil is wound on their central limbs. The main circuit basically consists of the contact assembly i.e. fixed contacts and moving contacts. Contactor may be single-pole or multi-pole. Its contacts may be a combination of normally open (NO) and normally closed (NC) type, depending on their natural status when control circuit is un-energized. The interlinking between moving core and moving contacts helps in opening or closing of power contacts.

Figure shows, in a simplified manner, the working principle of a three pole contactor with NO type main contacts.

When an energy supply is connected to the coil connections, it draws current, and produces a magnetic field. An upward electromagnetic force acts on the moving magnet, which moves towards the fixed magnet in order to reduce the overall reluctance of flux path. As the moving core's movement is linked to moving contacts, they too come in complete contact with the fixed contacts. This closes the main/power circuit and provides output to the connected load. By interruption of the coil control circuit the movable magnet core and thus also the contact assembly returns to their starting position. Contact spring returns the contacts to their normal state.

Modular contactors belong to the class of air-break switches. If coil power is removed, an arc is created as the contacts open. It is extinguished by separating the contacts by a sufficient distance. Air-break contactors are economic and have lesser maintenance costs in comparison to other classes of contactors (e.g. oil immersed, V acuum etc.).

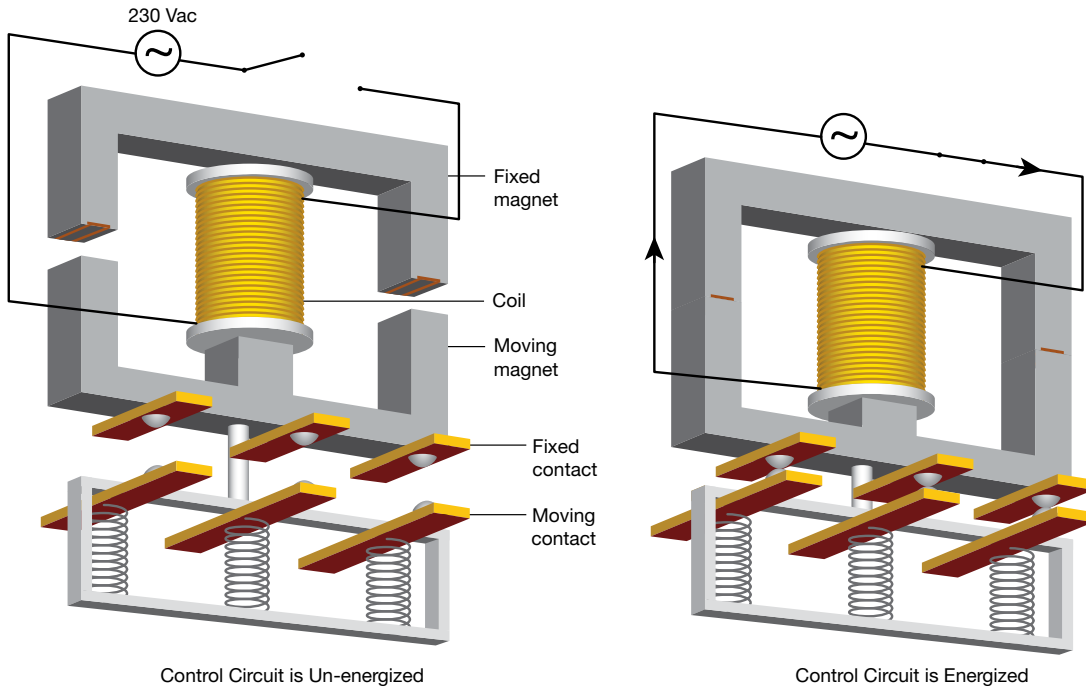

Working principle of contactor (explained w.r.t. NO contacts)

## Advantage 'Modular'

Modular DIN rail components are devices designed to be used with a standardized mounting rail having dimensions 35 mm x 7.5 mm (EN 50022). Such components are designed for a high degree of safety and finger protection. They are designed using the concept of modular width, and are either a fraction of, or multiples of, a single "module", which is standardized at 18 mm. Their compact construction saves space and increases customer benefits in building segment applications.

Havells modular contactors are the latest addition to our family of din-rail modular devices. In comparison to industrial contactors, they occupy a significantly reduced space. Modular contactors are suited for installation in a variety of day-to-day enclosures - distribution panels, switchboards, distribution boxes, consumer units etc.



## Utilization Categories

Contactors are a common electromechanical switching device used in industrial, commercial and residential applications. Utilization category plays an important role in their correct selection. Each category refers to different applications according to the switching conditions delivered by contactor (voltage, current, power factor, in-rush current, switching frequency, etc.)

Utilization categories of contactors as defined in IEC 60947-4-1	
Category	Typical applications
AC-1	Non-inductive or slightly inductive loads, resistance furnaces
AC-2	Slip-ring motors: starting, switching off
AC-3	Squirrel-cage motors: starting, switching off motors during running
AC-4	Squirrel-cage motors: starting, plugging, inching
AC-5a	Switching of electric discharge lamp controls (ballast)
AC-5b	Switching of incandescent lamps
AC-6a	Switching of transformers
AC-6b	Switching of capacitor banks
<b>AC-7a</b>	<b>Slightly inductive loads in household appliances and similar applications</b>
<b>AC-7b</b>	<b>Motor-loads for household applications</b>
AC-8a	Hermetic refrigerant compressor motor control with manual resetting of overload releases
AC-8b	Hermetic refrigerant compressor motor control with automatic resetting of overload releases
DC-1	Non-inductive or slightly inductive loads, resistance furnaces
DC-3	Shunt-motors: starting, plugging, inching. Dynamic breaking of d.c. Motors
DC-5	Series-motors: starting, plugging, inching. Dynamic breaking of d.c. Motors
DC-6	Switching of incandescent lamps

- Plugging means stopping or reversing the motor rapidly by reversing motor primary connections while the motor is running.
- Inching (jogging) means energizing a motor once or repeatedly for short periods to obtain small movements of the driven mechanism.
- Both AC-3 and AC-7a category may be used for occasional inching (jogging) or plugging for limited time periods such as machine set-up; during such limited time periods, the number of such operations should not exceed five per minute or more than ten in a 10 min period.

Modular contactors are compliant to IEC 61095. (This standard IEC 61095 applies to electromechanical air break contactors for household and similar purposes provided with main contacts intended to be connected to circuits the rated voltage of which does not exceed 440 V ac (between phases) and with rated operational currents less than or equal to 63 A for utilization category AC-7a and 32 A for utilization categories AC-7b and AC-7c, and rated conditional short-circuit current less than or equal to 6 kA).

The modular contactor's utilization category AC-7a is comparable to AC-1, but the slightly inductive loads find their use in household-like conditions. Their utilization category AC-7b is comparable to AC-3, but the motor loads find their use in household-like conditions.



## Building Automation in focus...

As users are becoming more conscious about energy saving and efficiency, electrical installations in modern buildings are being adapted to meet these requirements.

Modular contactors are a step in this direction as they can be easily integrated in building automation systems. Using contactors with multiple-function timers, push-buttons, switches, other centralized management systems etc. can save precious time, resources and energy.

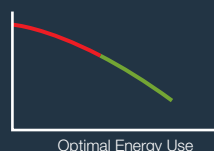

## Making & Breaking Capacities

Switching devices must always be selected based on the loads to be controlled, which differ in regards to making and breaking currents.

Categories	Making and breaking conditions						Reference standard
	$I_c/I_e$	$U_r/U_e$	$\text{Cos } \varphi$	On-time (s)	Off-time (s)	Number of operating cycles	
AC-1	1.5	1.05	0.8	0.05 <sup>(7)</sup> s	(1)	50	IEC 60947-4-1
AC-2	4.0 <sup>(4)</sup>	1.05	0.65 <sup>(4)</sup>	0.05 <sup>(7)</sup> s		50	IEC 60947-4-1
AC-3	8.0	1.05	"0.45 ( $I_e \leq 100$ A) 0.35 ( $I_e > 100$ A)"	0.05 <sup>(7)</sup> s		50	IEC 60947-4-1
AC-4	10	1.05		0.05 <sup>(7)</sup> s		50	IEC 60947-4-1
AC-5a	3	1.05	0.45	0.05 <sup>(7)</sup> s		50	IEC 60947-4-1
AC-5b	1.5 <sup>(2)</sup>	1.05	(2)	0.05 <sup>(7)</sup> s	60 s	50	IEC 60947-4-1
AC-6a	(3)						
AC-6b	1.5 <sup>(6)</sup>	1.05		(6)	(6)	50	IEC 60947-4-1
AC-7a	1.5	1.05	0.8	0.05 <sup>(7)</sup> s	(1)	50	IEC 61095
AC-7b	8.0	1.05	0.45	0.05 <sup>(7)</sup> s		50	IEC 61095
AC-8a	6.0	1.05	"0.45 ( $I_e \leq 100$ A) 0.35 ( $I_e > 100$ A)"	0.05 <sup>(7)</sup> s	(1)	50	IEC 60947-4-1
AC-8b	6.0	1.05		0.05 <sup>(7)</sup> s		50	IEC 60947-4-1

## Conventional Operations

Conventional Operational Performance covers the load test, which shows the circuit behavior under normal use. The contactor must be able to switch on and switch off under agreed conventional conditions and an agreed number of cycles without failure of the device.

Categories	Making and breaking conditions						Reference standard
	$I_c/I_e$	$U_r/U_e$	$\text{Cos } \varphi$	On-time (s)	Off-time (s)	Number of operating cycles	
AC-1	1.0	1.05	0.8	0.05 <sup>(7)</sup> s	(1)	6000(5)	IEC 60947-4-1
AC-2	2.0	1.05	0.65	0.05 <sup>(7)</sup> s		6000(5)	IEC 60947-4-1
AC-3	2.0	1.05	0.45 ( $I_e \leq 100$ A) 0.35 ( $I_e > 100$ A)	0.05 <sup>(7)</sup> s		6000(5)	IEC 60947-4-1
AC-4	6.0	1.05		0.05 <sup>(7)</sup> s		6000(5)	IEC 60947-4-1
AC-5a	2.0	1.05	0.45	0.05 <sup>(7)</sup> s		6000(5)	IEC 60947-4-1
AC-5b	1.0 <sup>(2)</sup>	1.05	(2)	0.05 <sup>(7)</sup> s	60 s	6000(5)	IEC 60947-4-1
AC-6a	(3)						
AC-6b	1 <sup>(6)</sup>	1.05		(6)	(6)	6000	IEC 60947-4-1
AC-7a	1.0	1.05	0.8	0.05 <sup>(7)</sup> s	(1)	30000	IEC 61095
AC-7b	6.0 (making) 1.0 (breaking)	1.0 (making) 0.17 (breaking)	0.45	0.05 <sup>(7)</sup> s		30000	IEC 61095
AC-8a	1.0	1.05	0.8	0.05 <sup>(7)</sup> s	(1)	30000	IEC 60947-4-1
AC-8b	6.0	1.05	"0.45 ( $I_e \leq 100$ A) 0.35 ( $I_e > 100$ A)"	1 s	9 s	5900	IEC 60947-4-1
				10 s	<200 s	100	IEC 60947-4-1

(1) Off time : 10 s ( $I_c \leq 100$  A), 20 s ( $100 < I_c \leq 200$ ), 30 s ( $200 < I_c \leq 300$ ), 40 s ( $300 < I_c \leq 400$ )...[Table 8 : IEC 60947-4-1]

(2) Use incandescent load during test

(3) Test with a transformer or derive the rating from the AC-3 values according to Table 9 (IEC 60947-4-1)

(4) The values shown are for stator contactors. For rotor contactors, test with  $I_c/I_e = 4$  and power factor 0.95

(5) For manually operated switching devices, the number of operating cycles shall be 1000 on-load, followed by 5000 off-load

(6) The load shall consist of commercially available capacitor combinations. Refer IEC 60947-4-1 for details.

(7) The time may be less than 50ms, provided that contacts are allowed to become properly seated before reopening.

$I_c$ : current made and broken, expressed in r.m.s. Symmetrical values, but it is understood that the actual peak value in the making operation may assume a higher value than the symmetrical peak value.

$I_e$ : rated operational current.

$U_r$ : Power frequency recovery voltage.

$U_e$ : rated operational voltage.

$\text{Cos } \varphi$ : Power factor of the test circuit.



## AUXILIARY CONTACT

### Dimensions (in mm)

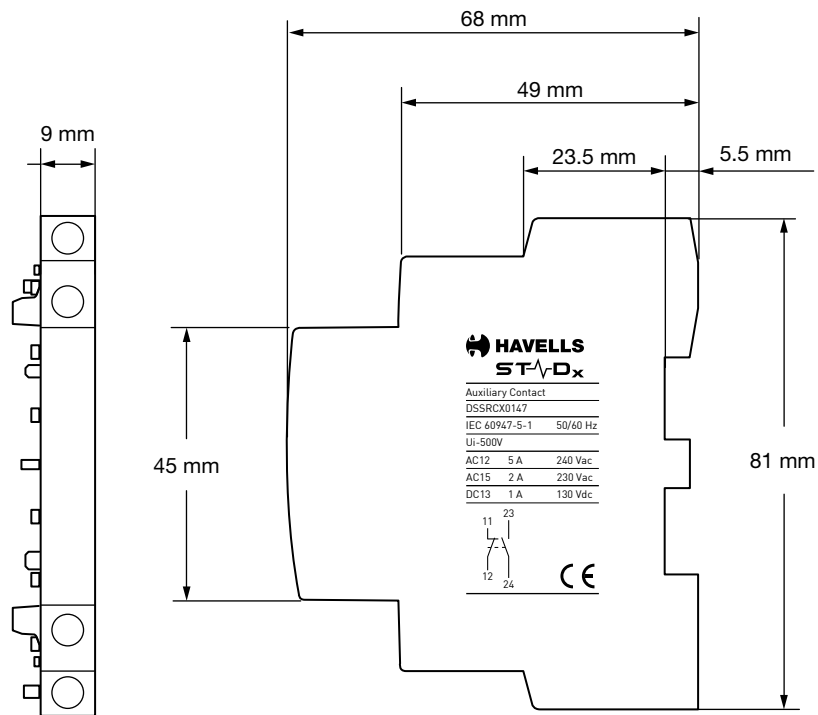

### Attachment

Fasten the auxiliary contact by slightly pressing it in place.

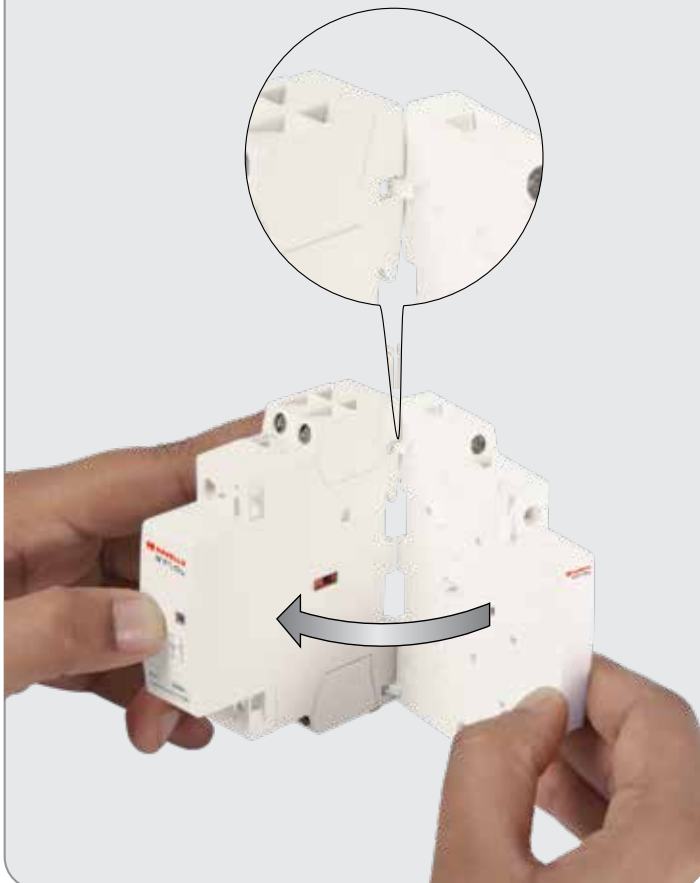

### Removal

Release the catch using a screwdriver.

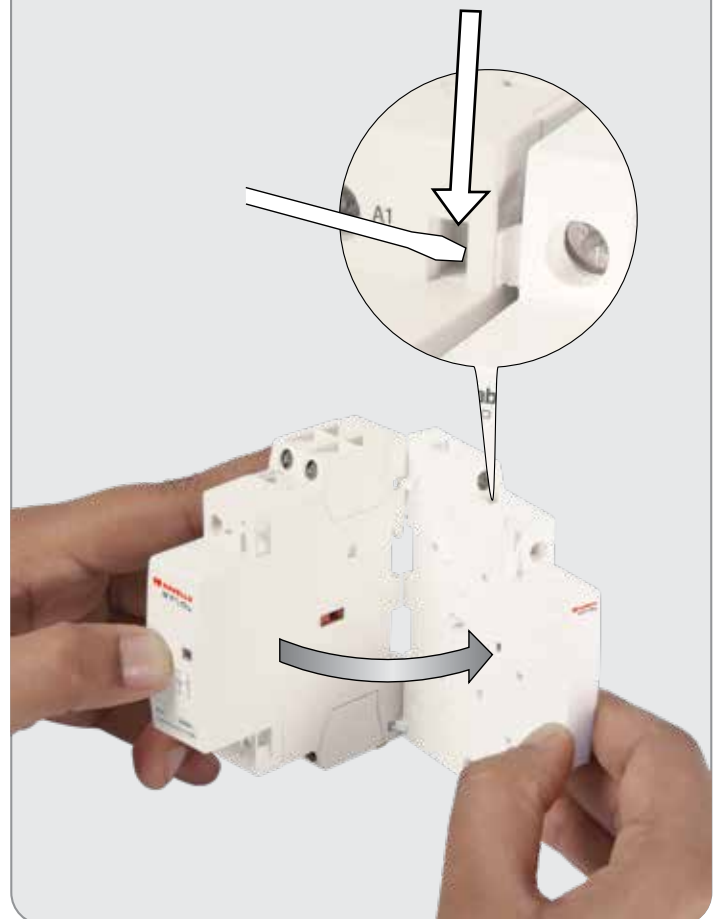

# AUTOMATIC MODULAR CONTACTOR WITH MANUAL OVERRIDE

Technical Specifications						
Product		Automatic Contactors with Manual Override				
Rating In		16 A	25 A	40 A	63 A	
<b>Main contacts</b>						
Standard		IEC/EN 61095	IEC/EN 61095	IEC/EN 61095	IEC/EN 61095	
Rated operational voltage Ue		Single phase-250 V~, Three phase-400 V~	Single phase-250 V~, Three phase-400 V~	Single phase-250 V~, Three phase-400 V~	Single phase-250 V~, Three phase-400 V~	
Rated operational current Ie	AC-7a	16 A	25 A	40 A	63 A	
	AC-7b	6 A	8.5 A	15 A	20 A	
Electrical endurance		100,000	100,000	100,000	100,000	
Switching operations frequency (per day)		100	100	100	100	
Rated breaking & making capacity (AC-7b)		48 A	68 A	120 A	160 A	
Conditional Short Circuit Current		3 kA	3 kA	3 kA	3 kA	
Type of Protection Device		MCB or gG fuse of adequate rating				
Rated duty		Continuous duty				
<b>Control circuit</b>						
Rated Control circuit voltage Uc		230 V~	230 V~	230 V~	230 V~	
Rated frequency		50 Hz/60 Hz	50 Hz/60 Hz	50 Hz/60 Hz	50 Hz/60 Hz	
Control circuit voltage limits		0.2...0.75 Uc at ≤50 °C drop-out, 0.85...1.1 Uc at ≤50 °C operational				
Coil Heat Dissipation (W)	SP, DP	1.2 W	1.2 W	1.6 W	1.6 W	
	TP, FP	-	1.6 W	2.1 W	2.1 W	
<b>Environment</b>						
Operating temperature		-5 °C...+60 °C	-5 °C...+60 °C	-5 °C...+60 °C	-5 °C...+60 °C	
Storage temperature		-40 °C...+70 °C	-40 °C...+70 °C	-40 °C...+70 °C	-40 °C...+70 °C	
Pollution Degree		2	2	2	2	
Degree of Protection		IP-20	IP-20	IP-20	IP-20	
<b>Insulation</b>						
Rated insulation voltage		500~	500~	500~	500~	
Rated impulse withstand voltage (kV)		4 kV	4 kV	4 kV	4 kV	
Dielectric Strength (kV)		2.5 kV	2.5 kV	2.5 kV	2.5 kV	
<b>Terminals</b>						
Tightening Torque (N-m)	Control	0.8 N-m	0.8 N-m	0.8 N-m	0.8 N-m	
	Power Contacts	0.8 N-m	0.8 N-m	3.5 N-m	3.5 N-m	
Terminal Capacity	Control	2x2.5 (Flexible), 2x1.5 (Rigid)				
	Power Contacts	Flexible	4 mm <sup>2</sup>	4 mm <sup>2</sup>	16 mm <sup>2</sup>	16 mm <sup>2</sup>
		Rigid	6 mm <sup>2</sup>	6 mm <sup>2</sup>	25 mm <sup>2</sup>	25 mm <sup>2</sup>

## Operation (Explained w.r.t. NO Configuration)

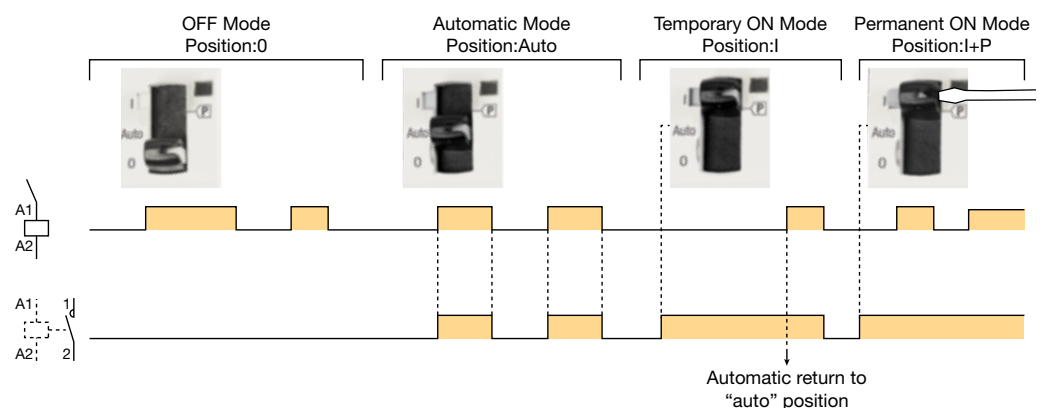

## Ordering Details

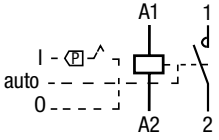
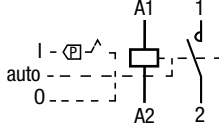
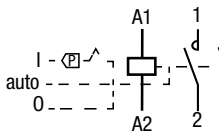
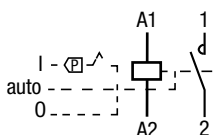
Poles	Rating AC-7a	Rating AC-7b	No. of Contacts	Width in Terms of Modular Size (18 mm)
1P	25 A	8.5 A	1 NO 	1
2P	16 A	6 A	2 NO 	1
	25 A	8.5 A		1
	40 A	15 A		2
	63 A	20 A		2
3P	25 A	8.5 A	3 NO 	2
	40 A	15 A		3
	63 A	20 A		3
4P	25 A	8.5 A	4 NO 	2
	40 A	15 A		3
	63 A	20 A		3

## Dimensions (in mm)

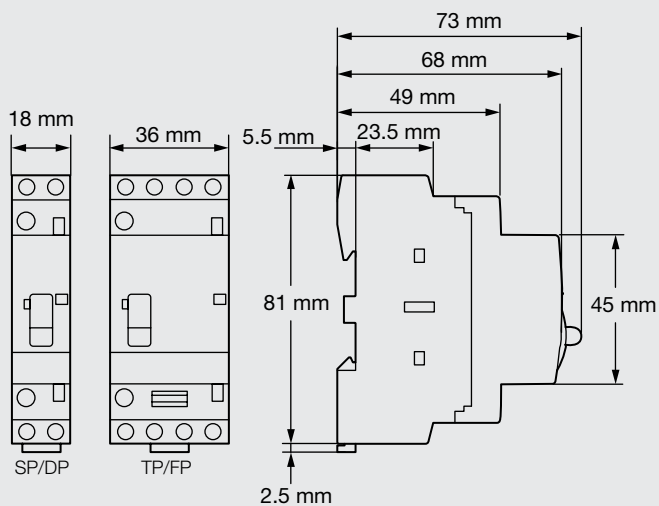

Automatic + Manual Modular Contactor 16 A/25 A

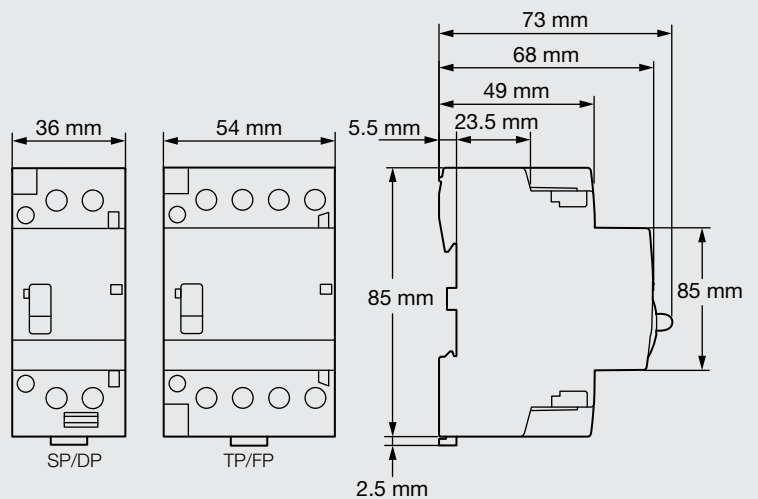

Automatic + Manual Modular Contactor 40 A/63 A

## Circuit Diagram - Modular Contactors

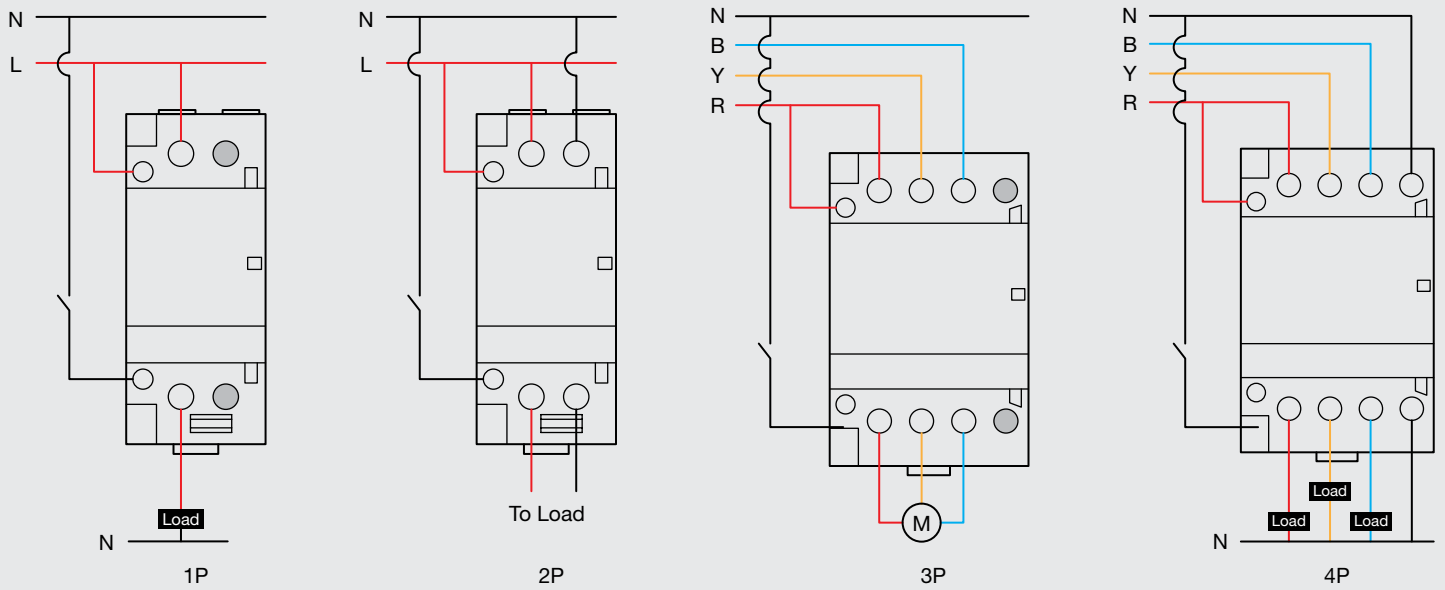

## Contactors With Auxiliary Contact

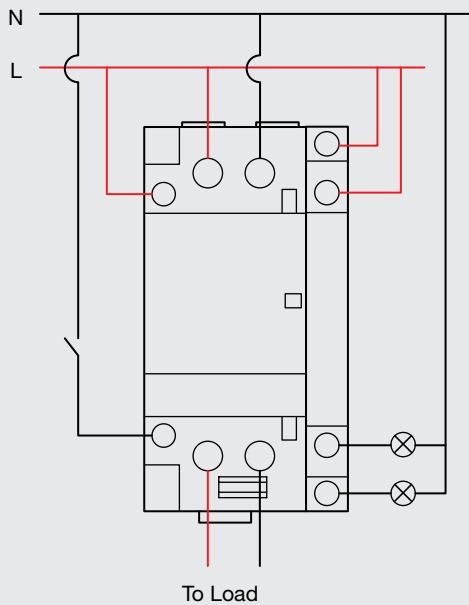

## Example

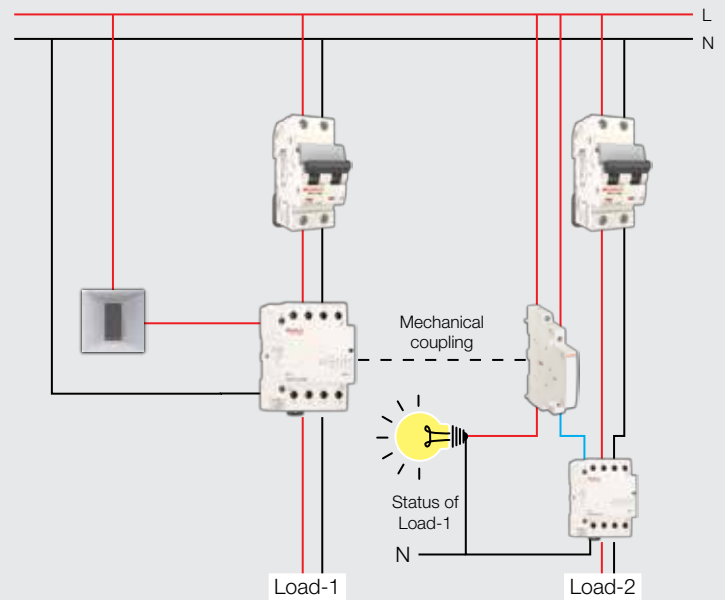

Figure shows the application of modular contactor with auxiliary contact: 1 NO+1 NC contact of auxiliary can be used for remote monitoring of contactor's status and control of alternate loads.



## MODULAR CONTACTORS CHOICE TABLE

**Heating Application:** Contactors rating to be chosen according to the power to be controlled and the number of operations a day.

Number of Operations/day	Maximum power for a given rating (kW)			
	16 A	25 A	40 A	63 A
<b>250 V Rated Voltage</b>				
25	3.4 kW	5.4 kW	8.6 kW	14 kW
50	3.4 kW	5.4 kW	8.6 kW	14 kW
75	2.9 kW	4.6 kW	7.3 kW	12 kW
100	2.7 kW	4 kW	6 kW	9.5 kW
<b>400 V Rated Voltage</b>				
25	10.5 kW	16 kW	26 kW	41 kW
50	10.5 kW	16 kW	26 kW	41 kW
75	8.9 kW	14 kW	22 kW	35 kW
100	6.7 kW	11 kW	17 kW	26 kW

**Small Motor Application:** Contactor rating to be chosen according to the power to be controlled.

Load and Rated Voltage	Maximum power for a given rating (kW)			
	16 A	25 A	40 A	63 A
250 V Asynchronous single-phase motor	0.95 kW	1.4 kW	2.5 kW	4 kW
400 V Asynchronous three-phase motor	2.7 kW	4 kW	7.5 kW	15 kW
250 V Universal motor	0.6 kW	0.9 kW	1.4 kW	2.2 kW

### Lighting Application

- Modern Lighting system generate a high inrush current. Therefore, It is recommended to use the following choice table to calculate maximum lamp load that can be connected per current path on 230 V, 50 Hz Circuits.
- The table below shows the permissible number of lamps for each contactor considering the type, power and configuration of a given lamp.
- In case a 4 pole-contactor is used (3 Ph+N), the below mentioned quantity of lamps need to be multiplied by 1.73 to obtain maximum number of lamps for the contactor. The obtained quantity has to be divided by 3 to evaluate maximum lamps per pole.

Type of lamp	Lamp Load and Power Factor Correction capacitance	Permissible number of Lamp fittings for a single phase 230 V, 50 Hz Circuit and Acceptable Power per circuit.			
		16 A	25 A	40 A	63 A
<b>Compact Fluorescent lamps(CFLs)</b>					
CFL with external electronic ballast		<b>1120 W-1400 W</b>	<b>1750 W-2190 W</b>	<b>3640 W-4300 W</b>	<b>5250 W</b>
	5 W	210	330	670	1025
	7 W	150	222	478	750
	9 W	122	194	383	583
	11 W	104	163	327	477
	18 W	66	105	213	291
	26 W	50	76	153	202
CFL with integrated electronic ballast		<b>800 W-900 W</b>	<b>1150 W-1300 W</b>	<b>2400 W-2675 W</b>	<b>3940 W-4000 W</b>
	5 W	160	230	470	710
	7 W	114	164	335	514
	9 W	94	133	266	411
	11 W	78	109	222	340
	18 W	48	69	138	213
	26 W	34	55	100	151

Incandescent lamps					
Tungsten halogen lamps 230 V		<b>1600 W-2050 W</b>	<b>2300 W-2900 W</b>	<b>4600 W-5200 W</b>	<b>6900 W-7500 W</b>
	40 W	38	57	115	172
	60 W	30	45	85	125
	75 W	25	38	70	100
	100 W	19	28	50	73
	150 W	12	18	35	50
	200 W	10	14	26	37
		<b>2100 W</b>	<b>3000 W</b>	<b>6000 W</b>	<b>8000 W</b>
	300 W	7	10	18	25
	500 W	4	6	10	15
	1000 W	2	3	6	8
Halogen ELV(12 V OR 24 V) with electronic transformer		<b>1350 W-1730 W</b>	<b>1800 W-2250 W</b>	<b>3650 W-4250 W</b>	<b>5500 W-6000 W</b>
	20 W	67	97	196	297
	25 W	27	42	82	123
	75 W	22	30	57	84
	100 W	17	24	45	64.8
Halogen ELV(12 V OR 24 V) with Ferromagnetic Transformer		<b>300 W-600 W</b>	<b>450 W-900 W</b>	<b>850 W-1950 W</b>	<b>1250 W-2850 W</b>
	20 W	5	23	42	63
	25 W	10	15	27	42
	75 W	8	12	23	35
	100 W	6	8	18	27
<b>Fluorescent Tubes</b>					
Single tube without parallel compensation		<b>350 W-870 W</b>	<b>490 W-1295 W</b>	<b>1130 W-2500 W</b>	<b>1500 W-3800 W</b>
	15 W	22	30	70	100
	18 W	22	30	70	100
	20 W	22	30	70	100
	36 W	20	28	60	90
	40 W	20	28	60	90
	58 W	13	17	35	56
	65 W	13	17	35	56
	80 W	10	15	30	48
	115 W	7	10	20	32
Single tube with parallel compensation		<b>200 W-800 W</b>	<b>325 W-1290 W</b>	<b>650 W-2500 W</b>	<b>970 W-3550 W</b>
	15 W, 5 µF	15	20	40	60
	18 W, 5 µF	15	20	40	60
	20 W, 5 µF	15	20	40	60
	36 W, 5 µF	15	20	40	60
	40 W, 5 µF	15	20	40	60
	58 W, 7 µF	10	15	30	43
	65 W, 7 µF	10	15	30	43
	80 W, 7 µF	10	15	30	43
115 W, 7 µF	5	7	14	20	



<b>Single tube with electronic ballast</b>		<b>1300 W-1400 W</b>	<b>2000 W-2200 W</b>	<b>4000 W-4400 W</b>	<b>6000 W-6600 W</b>
	18	74	111	222	333
	36	38	58	117	176
	58	25	37	74	111
<b>Double tube with electronic ballast</b>		<b>1300 W-1400 W</b>	<b>2000 W-2200 W</b>	<b>4000 W-4400 W</b>	<b>6000 W-6600 W</b>
	2x18	29	59	120	180
	2x36	22	32	64	97
	2x58	13	20	41	62

#### LEDs

<b>Double tube with electronic ballast LED 230 V without driver, Not dimmable</b>		<b>120 W-520 W</b>	<b>170 W-760 W</b>	<b>300 W-1360 W</b>	<b>500 W-1880 W</b>
	5W	24	34	61	100
	7 W	22	32	57	94
	9 W	22	32	57	94
	12 W	22	32	57	94
	18 W	21	30	54	77
	22 W	20	28	51	67
	30 W	16	23	42	53
<b>LED 230 V integrated driver, Dimmable</b>		<b>215 W-800 W</b>	<b>320 W-1200 W</b>	<b>575 W-2080 W</b>	<b>1440 W-2100 W</b>
	5 W	46	64	115	180
	7 W	46	64	115	180
	9 W	4	5	10	176
	12 W	44	61	110	176
	18 W	34	48	87	145
	22 W	30	42	76	119
	30 W	25	35	64	64
40 W	20	29	52	82	

#### Discharge lamps

<b>High pressure Sodium lamp /Metal iodide lamps with ferromagnetic ballast</b>		<b>600 W</b>	<b>850 W-1200 W</b>	<b>1450 W-2000 W</b>	<b>2250 W-3200 W</b>
	35 W	16	24	42	64
	70 W	8	12	20	32
	150 W	4	7	13	18
	250 W	2	4	8	11
	400 W	1	3	5	8
1000 W	0	1	2	3	

<b>High pressure Sodium lamp /Metal Iodide lamps, ferromagnetic ballast with parallel compensation.</b>		<b>450 W-1000 W</b>	<b>650 W-2000 W</b>	<b>1100 W-4000 W</b>	<b>1750 W-6000 W</b>
	35 W, 6 mF	12	18	31	50
	70 W, 12 $\mu$ F	6	9	16	25
	150 W, 20 $\mu$ F	4	6	10	15
	250 W, 32 $\mu$ F	3	4	7	10
	400 W, 45 $\mu$ F	2	3	5	7
	1000 W, 60 $\mu$ F	1	2	3	5
<b>High pressure Sodium lamp / Metal Iodide lamps with electronic ballast</b>		<b>830 W-1400 W</b>	<b>1350 W-2200 W</b>	<b>2400 W-4000 W</b>	<b>3600 W-6000 W</b>
	35 W	23	38	68	102
	70 W	17	29	51	76
	150 W	8	14	26	40
<b>High pressure Mercury Vapour lamp with Ferromagnetic Ballast</b>		<b>750 W-1000 W</b>	<b>1000 W-1600 W</b>	<b>1700 W-2800 W</b>	<b>2650 W-4200 W</b>
	50 W	15	20	34	53
	80 W	10	15	27	40
	125 W	8	10	20	28
	250 W	4	6	10	15
	400 W	2	4	6	10
	700 W	1	2	4	6
<b>High pressure Mercury Vapour lamp with Ferromagnetic Ballast and parallel compensation.</b>		<b>500 W-1400 W</b>	<b>750 W-1600 W</b>	<b>1400 W-3500 W</b>	<b>2150 W-5000 W</b>
	50 W, 7 $\mu$ F	10	15	28	43
	80 W, 8 $\mu$ F	9	13	25	38
	125 W, 10 $\mu$ F	9	10	20	30
	250 W, 18 $\mu$ F	4	6	11	17
	400 W, 40 $\mu$ F	3	4	8	12
	700 W, 60 $\mu$ F	2	2	5	7
<b>Low pressure Sodium Vapour lamp</b>		<b>270 W-360 W</b>	<b>320 W-720 W</b>	<b>500 W-1100 W</b>	<b>850 W-1800 W</b>
	35 W	5	9	14	24
	55 W	5	9	14	24
	90 W	3	6	9	19
	135 W	2	4	6	10
	180 W	2	4	6	10
<b>Low pressure Sodium Vapour lamp with parallel compensation</b>		<b>100 W-180 W</b>	<b>175 W-360 W</b>	<b>350 W-720 W</b>	<b>550 W-1100 W</b>
	35 W, 20 $\mu$ F	3	5	10	15
	55 W, 20 $\mu$ F	3	5	10	15
	90 W, 25 $\mu$ F	2	4	8	11
	135 W, 40 $\mu$ F	1	2	5	7
	180 W, 45 $\mu$ F	1	2	4	6

The given information is entirely indicative, Considerable variations may occur depending on the electrical installation and equipment used. It is recommended that the implementation or configuration of the circuits must be done by experienced professionals with the expertise to determine the characteristics of the electrical installation (General characteristics of installations, In rush Current duration and value, Load etc). The manufacturer accepts no liability for the use made of this information.



## IP 43 SPN DISTRIBUTION BOARD

Technical Specification	
No. of Ways	6 Ways, 8 Ways, 12 Ways & 16 Ways
Type of Installation	Flush / Surface
Colour / Finish	RAL 9016 Fine Texture
Door Options	Rectangular with Rounded Corner
Removable Gland Plates	Top & Bottom
Distribution Technique	Straight Bus bar
Copper Bus bar	Tin Plated
Bus bar Rating	100 A
Bus bar Short Time Withstand (Icw)	5 kA for 0.1 second
Bus bar Conditional Short Circuit (Ics)	10 kA
Incoming	Max 100 A
Outgoing	Max. Individual 63 A
Voltage Rating	240 V ac, 1 Phase
Incoming Options	100 A Isolator (2P) or 100 A RCCB (2P)
Neutral Bar	Brass
Earth bar	Brass
Neutral Bar Terminal Capacity	25 mm <sup>2</sup>
Earthing Bar Terminal Capacity	16 mm <sup>2</sup>
Din Bar	Powder Coated
Enclosure Material	Powder coated CRCA steel sheet 1.0 mm
Impact Protection	IK 09
Degree of Protection (IP)	IP 43
Insulation Voltage (Ui)	690 V ac
Frequency	50 Hz
Ambient Temperature	-5 °C to 40 °C
Distribution Board - Ref. Spec.	IS 13032 ; IEC 61439-3 , IS 8623
Index of Protection(IP) - Ref. Spec.	IEC 60529

### Dimensions (in mm)

No. of Ways	A	B	C	KNOCK OUT HOLES				
				Top		Bottom		Side
				Ø26	Ø32	Ø26	Ø32	Ø26
6 Ways	276	122	248	4	-	4	-	1
8 Ways	312	158	284	2	2	2	2	1
12 Ways	384	230	356	4	2	4	2	1
16 Ways	456	302	428	6	2	6	2	1

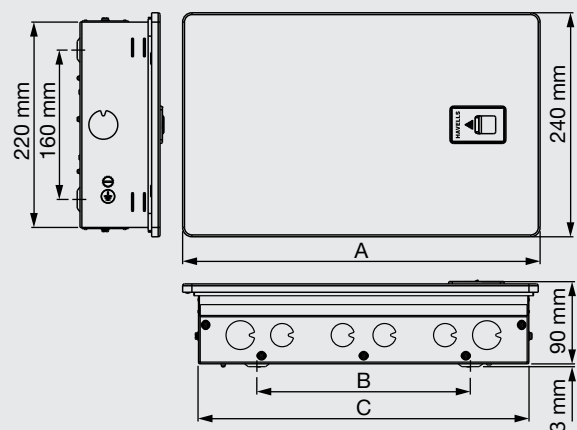

# IP 43 TPN DISTRIBUTION BOARD

Technical Specification	
No. of Ways	4 Ways Eco, 4 Ways, 6 Ways, 8 Ways & 12 Ways
Type of Installation	Flush / Surface
Colour / Finish	RAL 9016 Fine Texture
Door Options	Rectangular with Rounded Corner
Removable Gland Plates	Top & Bottom
Distribution Technique	Straight Bus bar
Copper Bus bar	Tin Plated
Bus bar Rating	100 A
Bus bar Short Time Withstand (Icw)	5 kA for 0.1 second
Bus bar Conditional Short Circuit (Ics)	10 kA
Incoming	Max 100 A
Outgoing	Max. Individual 63 A
Voltage Rating	415 V ac, 3 Phase
Incoming Options	100 A Isolator (4P) or 100 A RCCB (4P)
Neutral Bar	Brass
Earth bar	Brass
Neutral Bar Terminal Capacity	25 mm <sup>2</sup>
Earthing Bar Terminal Capacity	16 mm <sup>2</sup>
Din Bar	Powder Coated
Enclosure Material	Powder coated CRCA steel sheet 1.0 mm
Impact Protection	IK 09
Degree of Protection (IP)	IP 43
Insulation Voltage (Ui)	690 V ac
Frequency	50 Hz
Ambient Temperature	-5 °C to 40 °C
Distribution Board - Ref. Spec.	IS 13032 ; IEC 61439-3 , IS 8623
Index of Protection(IP) - Ref. Spec.	IEC 60529

## Dimensions (in mm)

No. of Ways	A	B	C	KNOCK OUT HOLES		
				Top Ø32	Bottom Ø32	Side Ø32
4 Ways Eco	356	162	328	6	6	1
4 Ways	392	198	364	6	6	1
6 Ways	428	234	400	8	8	1
8 Ways	500	306	472	8	8	1
12 Ways	644	450	616	10	10	1

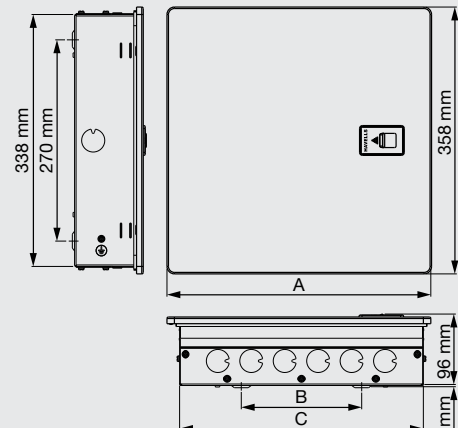

## IP 43 FLEXI TIER DD DISTRIBUTION BOARD

Technical Specification	
No. of Ways	2 Tier 24 Module, 3 Tier 36 Module, 4 Tier 40 Module, 4 Tier 56 Module
Type of Installation	Flush / Surface
Colour / Finish	RAL 9016 Fine Texture
Door Options	Rectangular with Rounded Corner
Removable Gland Plates	Top & Bottom
Distribution Technique	Straight Bus bar
Copper Bus bar	Tin Plated
Bus bar Rating	100 A
Bus bar Short Time Withstand (Icw)	5 kA for 0.1 second
Bus bar Conditional Short Circuit (Ics)	10 kA
Incoming	Max 100 A
Outgoing	Max. Individual 63 A
Voltage Rating	240 V ac, 1 Phase
Incoming Options	100 A Isolator (2P) or 100 A RCCB (2P)
Earth Leakage Protective Devices	RCCB / RCBO
Neutral Bar	Brass
Earth bar	Brass
Neutral Bar Terminal Capacity	25 mm <sup>2</sup>
Earthing Bar Terminal Capacity	16 mm <sup>2</sup>
Din Bar	Powder Coated
Enclosure Material	Powder coated CRCA steel sheet 1mm
Impact Protection	IK 09
Degree of Protection (IP)	IP 43
Insulation Voltage (Ui)	690 V ac
Frequency	50 Hz
Ambient Temperature	-5 °C to 40 °C
Distribution Board - Ref. Spec.	IS 13032 ; IEC 61439-3 , IS 8623
Protective Devices - Reference Standard	IS/IEC 60947-2 ; IS/IEC 60898 ; IS/IEC 60947-3
Residual Current Protective Devices - Reference Standard	IS/IEC 61009 ; IS/IEC 61008
Index of Protection(IP) - Ref. Spec.	IEC 60529

### Dimensions (in mm)

No. of Ways	A	B	C	KNOCK OUT HOLES		
				Top	Bottom	Side
				Ø32	Ø32	Ø32
2T24M	366	270	386	7	7	2
3T36M	516	420	536	7	7	2
4T40M	386	284	359	7	7	2
4T56M	458	356	431	8	8	2

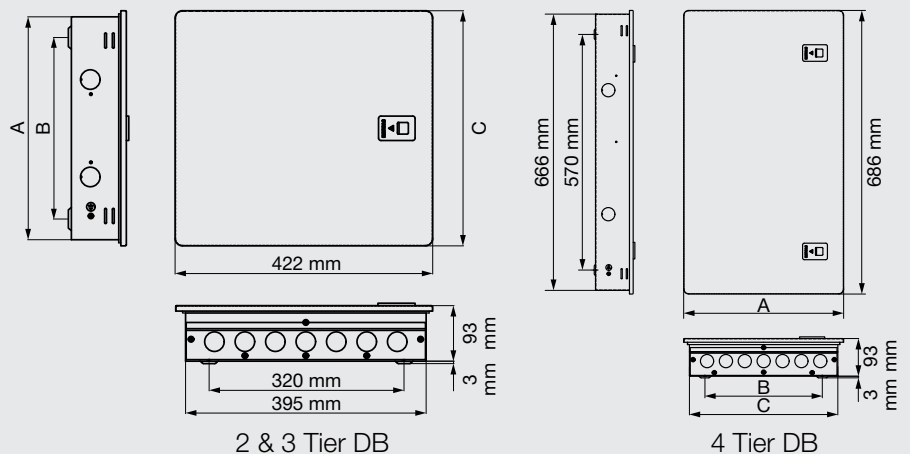

# IP 43 VERTICAL PHASE SELECTOR DISTRIBUTION BOARD

Technical Specification	
No. of Ways	4 Ways, 6 Ways & 8 Ways
Type of Installation	Flush / Surface
Colour / Finish	RAL 9016 Fine Texture
Door Options	Rectangular with Rounded Corner
Removable Gland Plates	Top & Bottom
Distribution Technique	Straight Bus bar
Copper Bus bar	Tin Plated
Bus bar Rating	100 A
Bus bar Short Time Withstand (Icw)	5 kA for 0.1 second
Bus bar Conditional Short Circuit (Ics)	10 kA
Incoming	Max 63 A Per Phase
Outgoing	Max. Individual 32 A
Voltage Rating	240 V ac - 415 V ac, 3 Phase
Incoming Option	100 A Isolator & R, Y, B Indicating Lights (TPN) & 100 A RCCB
Neutral Bar	Brass
Earth bar	Brass
Neutral Bar Terminal Capacity	25 mm <sup>2</sup>
Earthing Bar Terminal Capacity	16 mm <sup>2</sup>
Din Bar	Powder Coated
Enclosure Material	Powder coated CRCA steel sheet 1.2 mm
Impact Protection	IK 09
Degree of Protection (IP)	IP 43
Insulation Voltage (Ui)	690 V ac
Frequency	50 Hz
Ambient Temperature	-5 °C to 40 °C
Distribution Board - Ref. Spec.	IS 13032 ; IEC 61439-3 , IS 8623
Index of Protection(IP) - Ref. Spec.	IEC 60529

## Dimensions (in mm)

No. of Ways	A	B	C	KNOCK OUT HOLES		
				Top	Bottom	Side
				Ø26	Ø26	Ø26
4 Ways	391	288	363	7	7	3
6 Ways	427	324	399	8	8	3
8 Ways	463	360	435	9	9	3

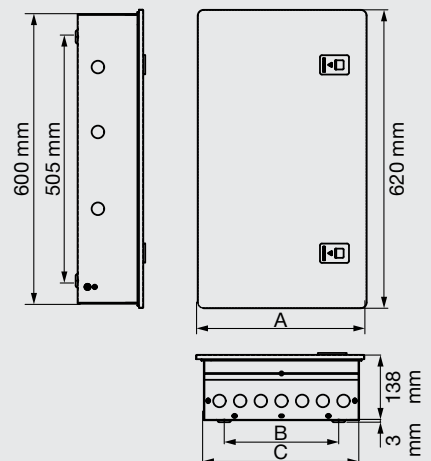

## IP 43 PPI TPN HORIZONTAL DISTRIBUTION BOARD

Technical Specification	
No. of Ways	4 Ways, 6 Ways, 8 Ways & 12 Ways
Type of Installation	Flush / Surface
Colour / Finish	RAL 9016 Fine Texture
Door Options	Rectangular with Rounded Corner
Removable Gland Plates	Top & Bottom
Distribution Technique	Straight Bus bar
Copper Bus bar	Tin Plated
Bus bar Rating	100 A
Bus bar Short Time Withstand (Icw)	5 kA for 0.1 second
Bus bar Conditional Short Circuit (Ics)	10 kA
Incoming	Max 100 A
Outgoing	Max. Individual 63 A
Voltage Rating	415 V ac, 3 Phase
Main Incomer Option	100 A Isolator (4P)
Sub Incomer Option	DP RCCB
Neutral Bar	Brass
Earth bar	Brass
Neutral Bar Terminal Capacity	25 mm <sup>2</sup>
Earthing Bar Terminal Capacity	16 mm <sup>2</sup>
Din Bar	Powder Coated
Enclosure Material	Powder coated CRCA steel sheet 1.0 mm
Impact Protection	IK 09
Degree of Protection (IP)	IP 43
Insulation Voltage (Ui)	690 V ac
Frequency	50 Hz
Ambient Temperature	-5 °C to 40 °C
Distribution Board - Ref. Spec.	IS 13032 ; IEC 61439-3 , IS 8623
Index of Protection(IP) - Ref. Spec.	IEC 60529

### Dimensions (in mm)

No. of Ways	A	B	C	D	E	KNOCK OUT HOLES		
						Top	Bottom	Side
						Ø32	Ø32	Ø32
2+4 Ways	468	234	440	340.4	358	8	8	1
2+6 Ways	504	270	476	340.4	358	10	10	1
2+8 Ways	576	342	548	340.4	358	10	10	1
2+12 Ways	743	501	707	368	388	12	12	1

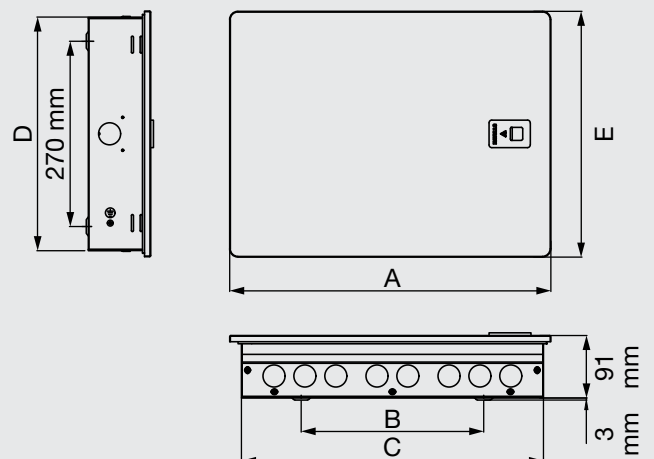

# IP 43 PHASE SEGREGATED 8 SEGMENT DISTRIBUTION BOARD

Technical Specification	
No. of Ways	4 Ways, 6 Ways, 8 Ways & 12 Ways
Type of Installation	Flush / Surface
Colour / Finish	RAL 9016 Fine Texture
Door Options	Rectangular with Rounded Corner
Removable Gland Plates	Top & Bottom
Distribution Technique	Straight Bus bar
Copper Bus bar	Tin Plated
Bus bar Rating	100 A
Bus bar Short Time Withstand (Icw)	5 kA for 0.1 second
Bus bar Conditional Short Circuit (Ics)	10 kA
Incoming	Max 100 A
Outgoing	Max. Individual 63 A
Voltage Rating	415 V ac, 3 Phase
Main Incomer Option	100 A Isolator (4P)
Sub Incomer Option	DP RCCB
Neutral Bar	Brass
Earth bar	Brass
Neutral Bar Terminal Capacity	25 mm <sup>2</sup>
Earthing Bar Terminal Capacity	16 mm <sup>2</sup>
Din Bar	Powder Coated
Enclosure Material	Powder coated CRCA steel sheet 1.2 mm
Impact Protection	IK 09
Degree of Protection (IP)	IP 43
Insulation Voltage (Ui)	690 V ac
Frequency	50 Hz
Ambient Temperature	-5 °C to 40 °C
Distribution Board - Ref. Spec.	IS 13032 ; IEC 61439-3 , IS 8623
Index of Protection(IP) - Ref. Spec.	IEC 60529

## Dimensions (in mm)

No. of Ways	A	B	C	KNOCK OUT HOLES		
				Top	Bottom	Side
				Ø32	Ø32	Ø32
4 Ways	567	460	530	9	9	2
6 Ways	597	490	560	9	9	2
8 Ways	675	568	638	12	12	2
12 Ways	891	784	854	15	15	2

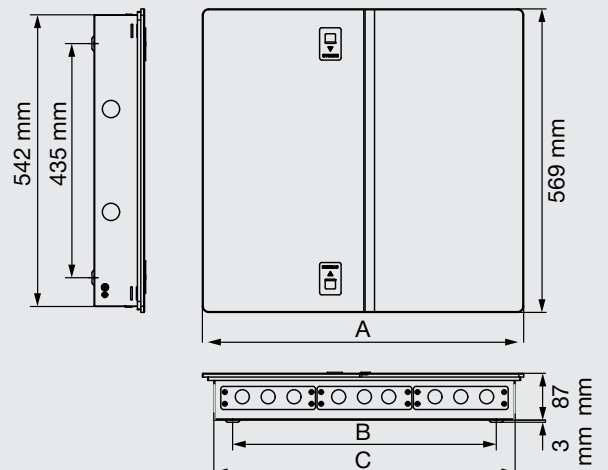

## IP 43 VTPN MODULAR INCOMER DISTRIBUTION BOARD

Technical Specification	
No. of Ways	4 Ways, 6 Ways, 8 Ways & 12 Ways
Type of Installation	Flush / Surface
Colour / Finish	RAL 9016 Fine Texture
Door Options	Rectangular with Rounded Corner
Removable Gland Plates	Top & Bottom
Distribution Technique	Fish-bone Bus bar
Copper Bus bar	Tin Plated
Bus bar Rating	100 A
Bus bar Short Time Withstand (Icw)	5 kA for 0.1 second
Bus bar Conditional Short Circuit (Ics)	10 kA
Incoming	Max 100 A
Outgoing	Max. Individual 63 A
Voltage Rating	240 V ac - 415 V ac, 3 Phase
Incoming Options	100 A Isolator (4P) or 100 A RCCB (4P)
Neutral Bar	Brass
Earth bar	Brass
Neutral Bar Terminal Capacity	25 mm <sup>2</sup>
Earthing Bar Terminal Capacity	16 mm <sup>2</sup>
Din Bar	Powder Coated
Enclosure Material	Powder coated CRCA steel sheet 1.2 mm
Impact Protection	IK 09
Degree of Protection (IP)	IP 43
Insulation Voltage (Ui)	690 V ac
Frequency	50 Hz
Ambient Temperature	-5 °C to 40 °C
Distribution Board - Ref. Spec.	IS 13032 ; IEC 61439-3 , IS 8623
Index of Protection(IP) - Ref. Spec.	IEC 60529

### Dimensions (in mm)

No. of Ways	A	B	C	KNOCK OUT HOLES		
				Top	Bottom	Side
				Ø32	Ø32	Ø32
4 Ways	450	340	472	6	6	2
6 Ways	504	396	526	6	6	2
8 Ways	558	450	580	6	6	2
12 Ways	666	558	688	6	6	2

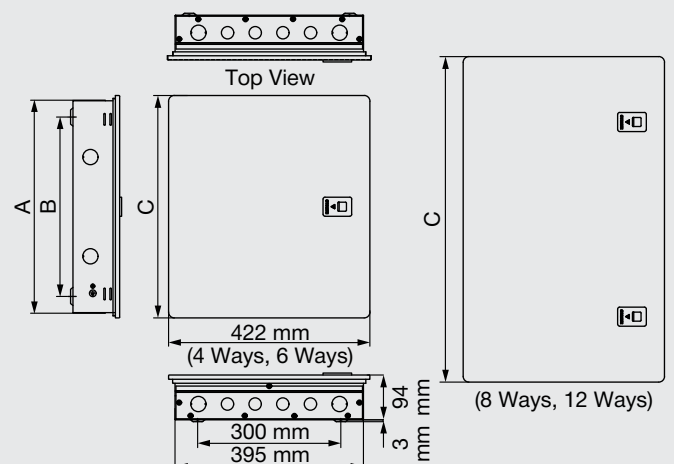

# IP 43 VTPN WITH MCCB INCOMER DISTRIBUTION BOARD

Technical Specification	
No. of Ways	4 Ways, 6 Ways, 8 Ways & 12 Ways
Type of Installation	Flush / Surface
Colour / Finish	RAL 9016 Fine Texture
Door Options	Rectangular with Rounded Corner
Removable Gland Plates	Top & Bottom
Distribution Technique	Fish-bone Bus bar
Copper Bus bar	Tin Plated
Bus bar Rating	160 A / 250 A
Bus bar Short Time Withstand (Icw)	10 kA for 0.5 second
Bus bar Conditional Short Circuit (Ics)	25 kA
Incoming	Max 160 A / Max 250 A
Outgoing	Max. Individual 63 A
Voltage Rating	240 V ac - 415 V ac, 3 Phase
Incoming Options	160 A G Frame / 250 A A Frame MCCB TP/FP
Neutral Bar	Brass
Earth bar	Brass
Neutral Bar Terminal Capacity	25 mm <sup>2</sup> / 35 mm <sup>2</sup>
Earthing Bar Terminal Capacity	16 mm <sup>2</sup>
Din Bar	Powder Coated
Enclosure Material	Powder coated CRCA steel sheet 1.2 mm
Impact Protection	IK 09
Degree of Protection (IP)	IP 43
Insulation Voltage (Ui)	690 V ac
Frequency	50 Hz
Ambient Temperature	-5 °C to 40 °C
Distribution Board - Ref. Spec.	IS 13032 ; IEC 61439-3 , IS 8623
Index of Protection(IP) - Ref. Spec.	IEC 60529

## Dimensions (in mm)

No. of Ways	A (160 A)	B (160 A)	C (160 A)	A (250 A)	B (250 A)	C (250 A)	KNOCK OUT HOLES			
							Top		Side	
							Ø32	Ø32	Ø50	Ø32
4 Ways	562	462	580	690	590	710	6	4	1	2
6 Ways	616	516	634	744	644	764	6	4	1	2
8 Ways	670	570	688	798	698	818	6	4	1	2
12 Ways	778	678	796	906	806	926	6	4	1	2

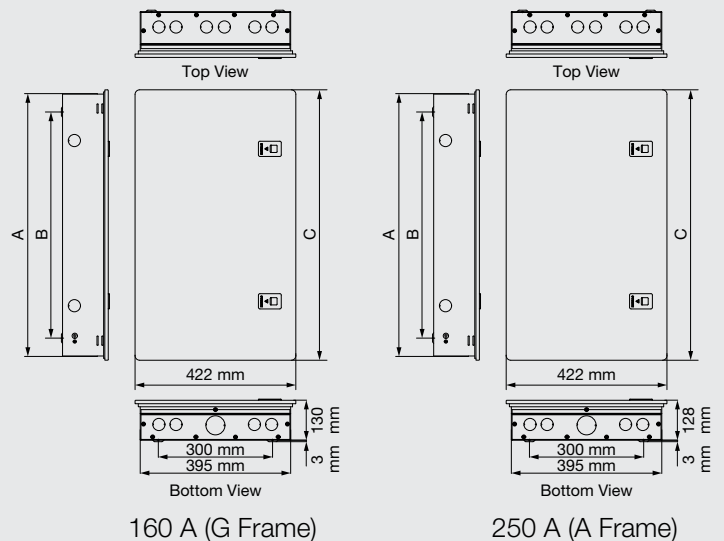





# OFFICE BUILDING





## Customer Needs:

- 1. Energy optimization & monitoring:** In office building, proper lighting, Air conditioning and ventilation plays an important role. Energy consumption depends on the lighting/ AC efficiency, input power, type, number of lamps used, office space/ area, optimize use of lights and AC.
- 2. Malfunction Alerts:** Any malfunction must immediately alert the maintenance staff.
- 3. Easy maintenance:** The maintenance staff must be able to diagnose the malfunction and put the equipment back into service very quickly: remotely, where possible, or on site.

## Proposed Solution:

- 1. Remote monitoring:** The Bridge and auxiliaries devices enables all the terminal switchboards to be directly connected to the site monitoring network.
- 2. Status Indication for faults:** The circuit breaker auxiliaries indicate any tripping or deliberate opening. Auto recloser devices used for automated closing of circuit breaker. The contactors receive the On/Off switching orders and its auxiliary indicate their state.
- 3. Service & repair remote operated :** Service person can check the fault location remotely on PC.

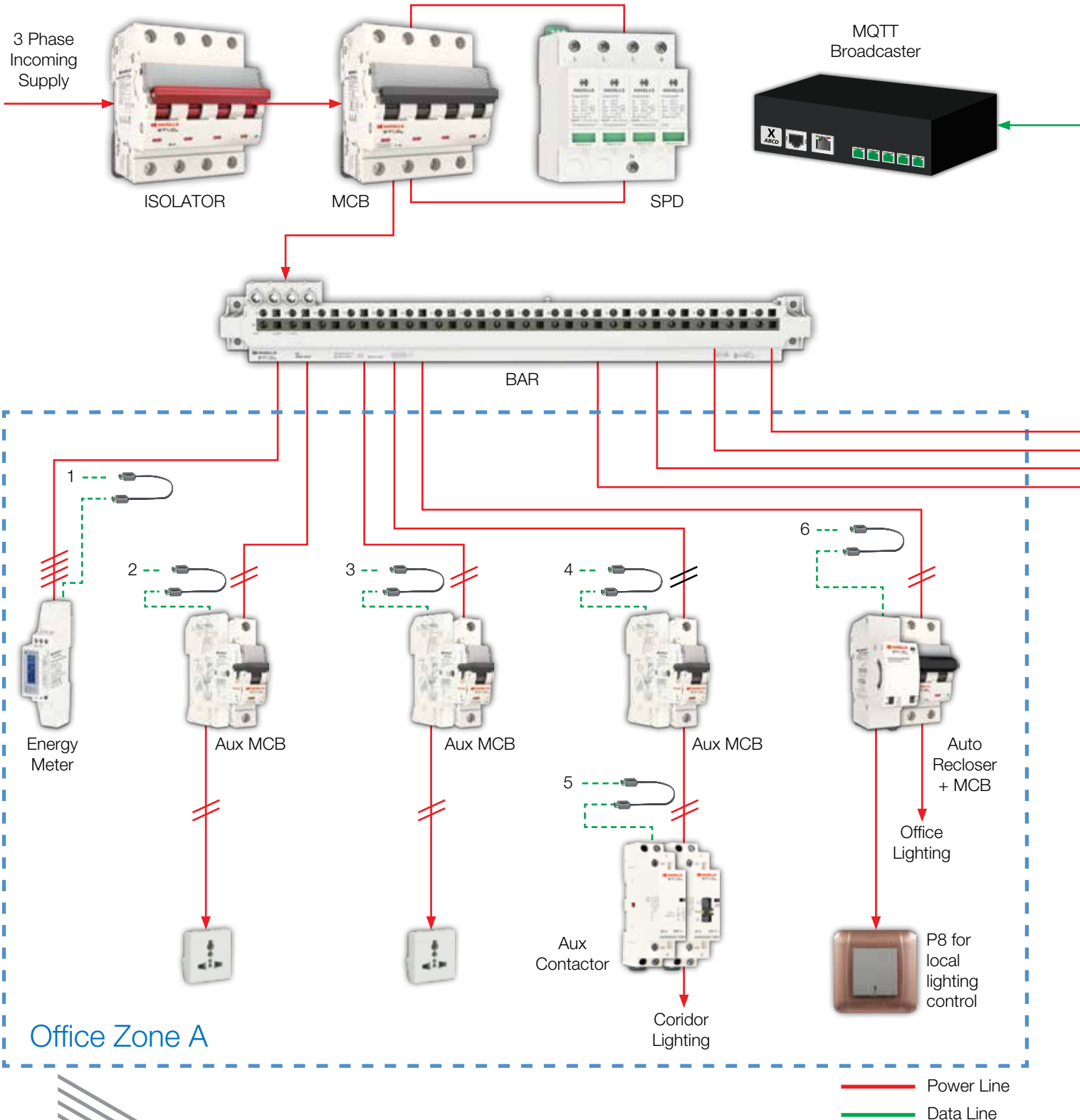

## Benefits:

- 1. Expense minimisation:** Reduction in electricity expenses through management of lighting or other devices, by optimization related to human presence. The user can perfectly control energy consumption for each zone.
- 2. Solution scalability** in the event of reallocation or addition of zones. Bridge solution allows fast and reliable changes for efficient connections with minimal wiring in the distribution board.
- 3. Ensuring occupant comfort** while reducing operating costs, through last detection and pinpointing in the event of a malfunction on an electrical board.
- 4. The devices are connected** to the Modbus network via the Bridge communication interfaces and fully prefabricated connectors:
  - cabling is quickly and easily installed,
  - easy maintenance and fault detection, No handling tool required for the same.

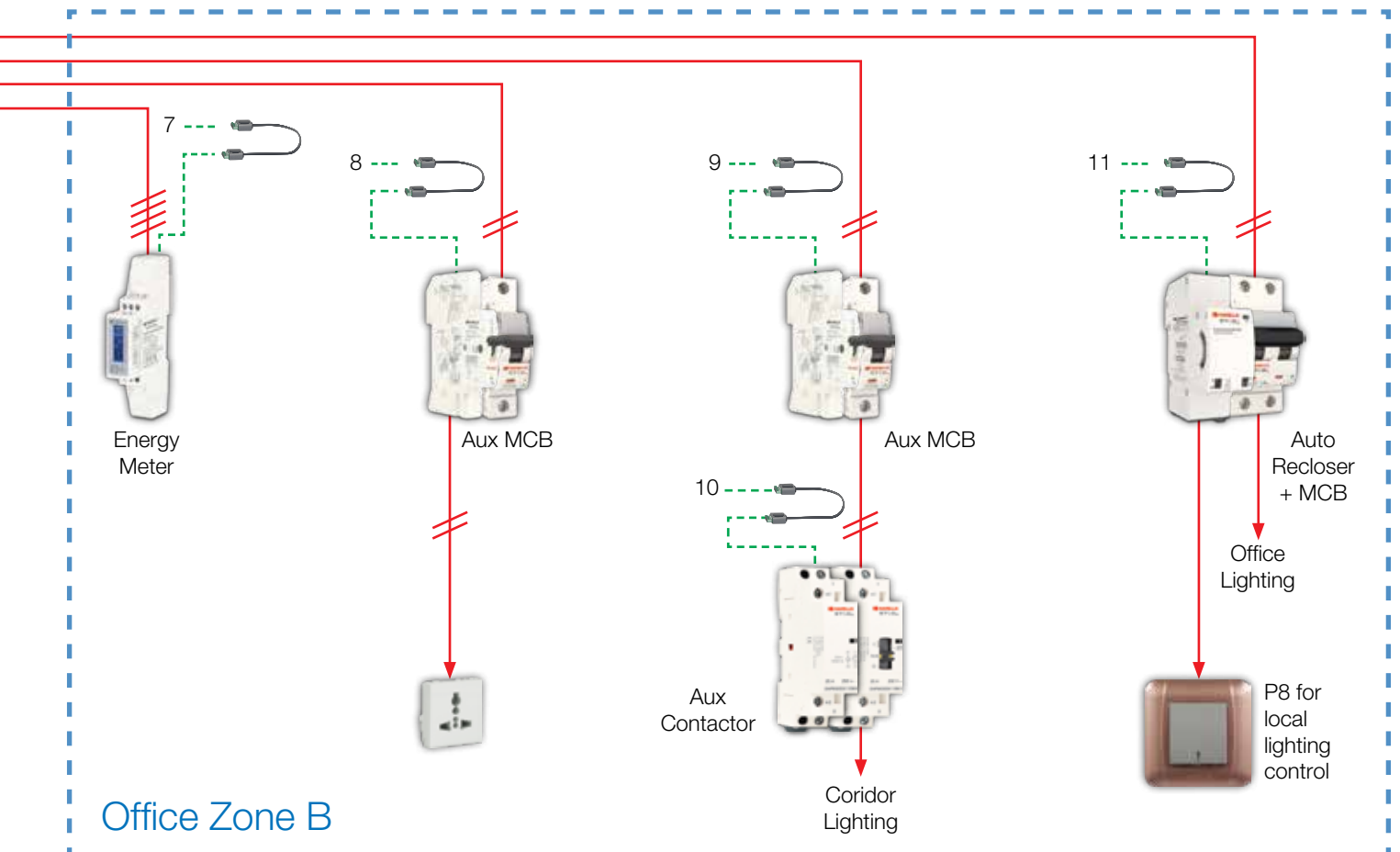
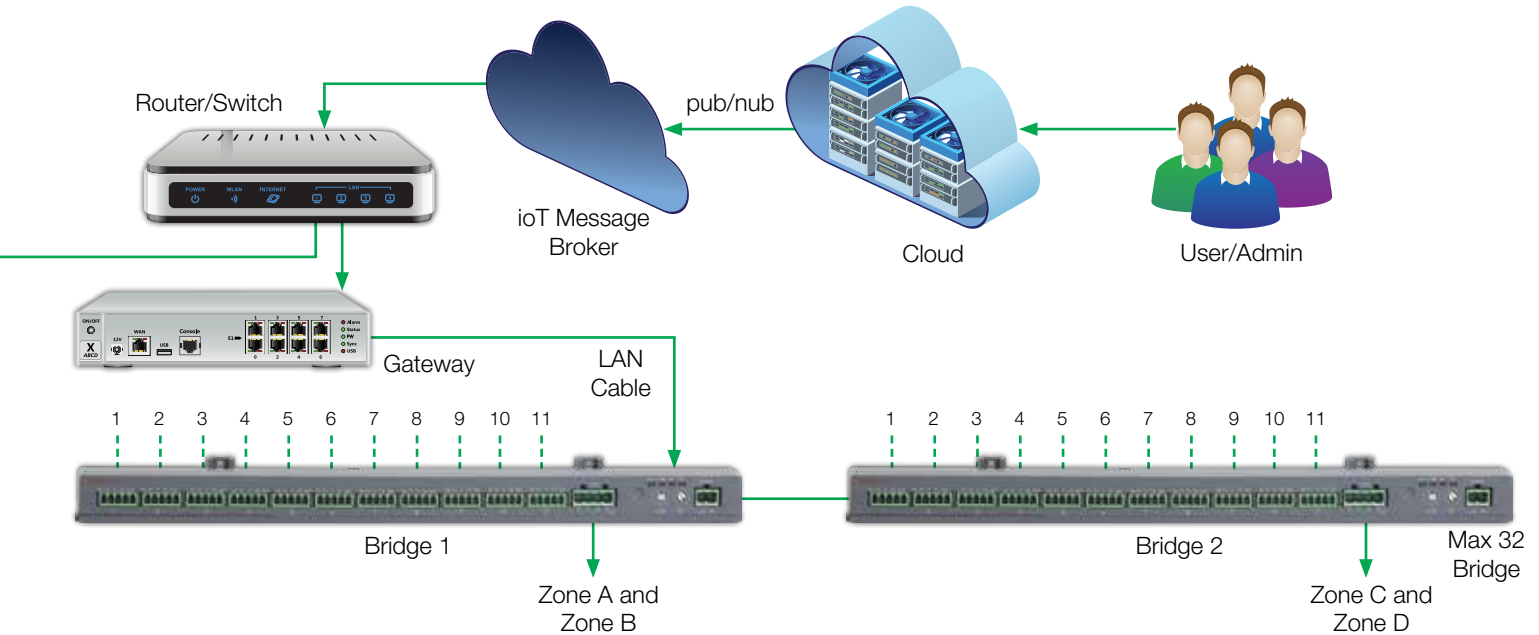

Office Zone B



# DATA CENTER



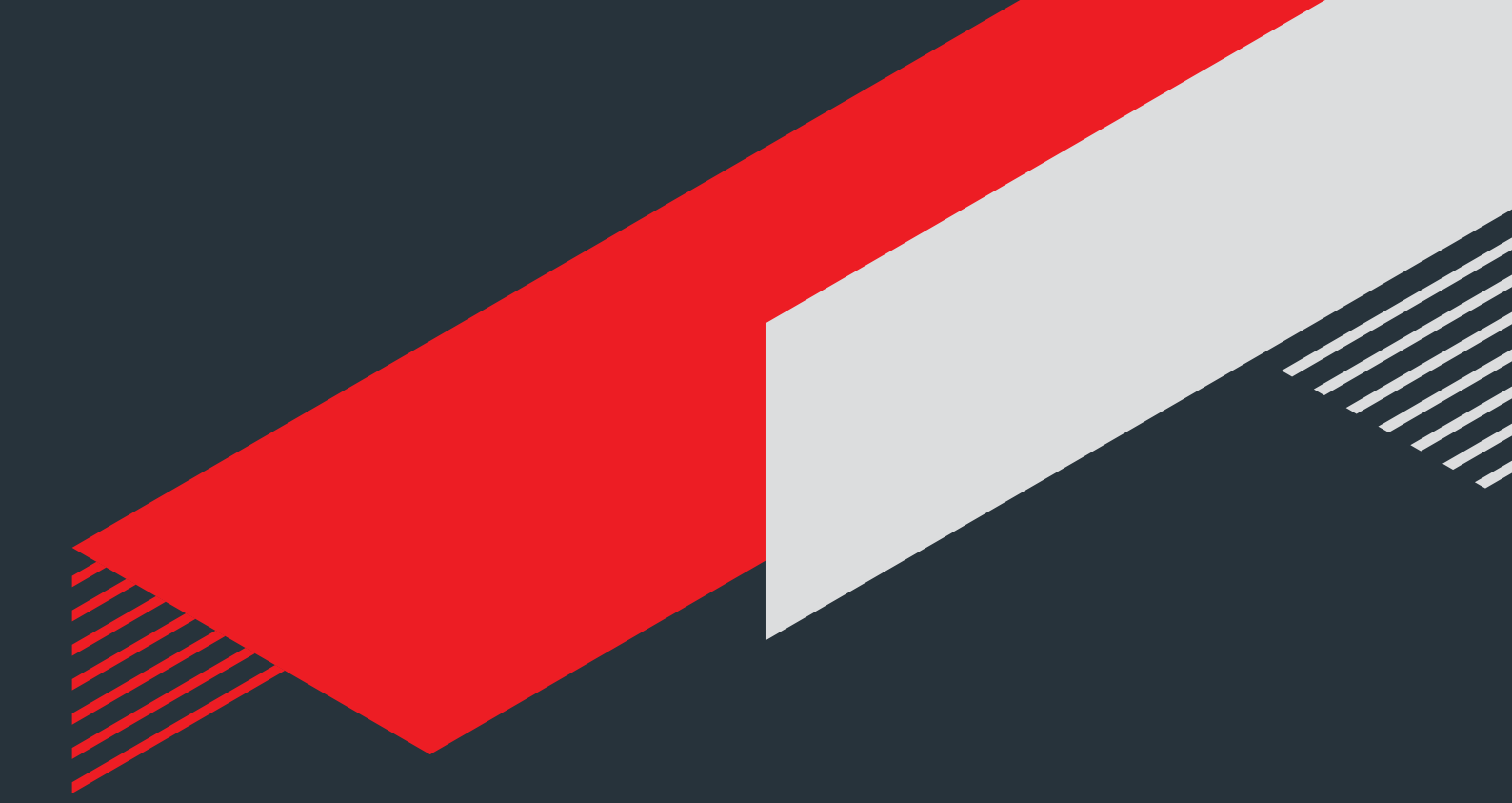

**Benefits:**

- 1. **Fault warning/ alert:** Alert signal is sent as soon as the protection devices trips. Also allows to precisely detects fault location.
- 2. **Optimized investment** with a system designed and operated functions.

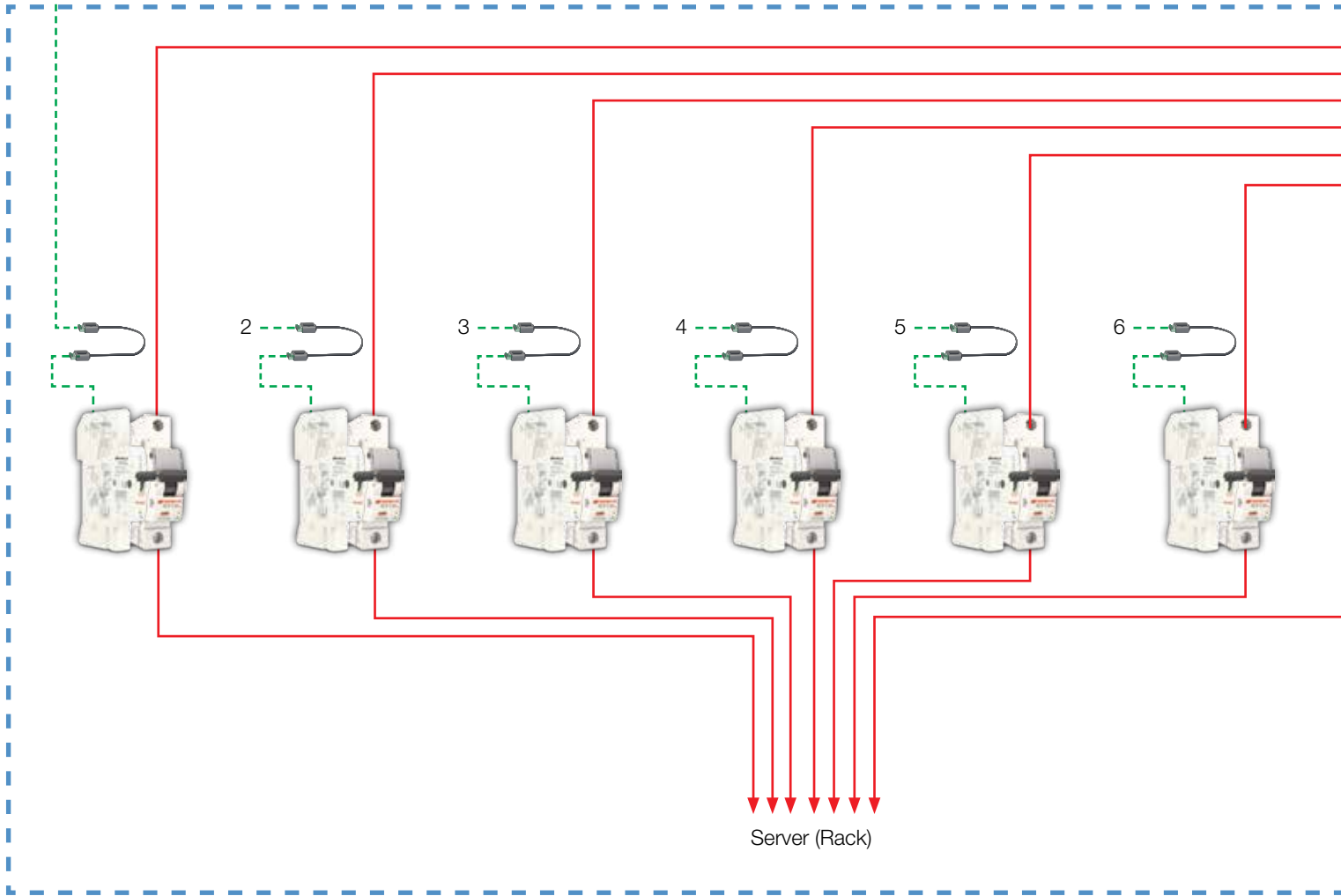
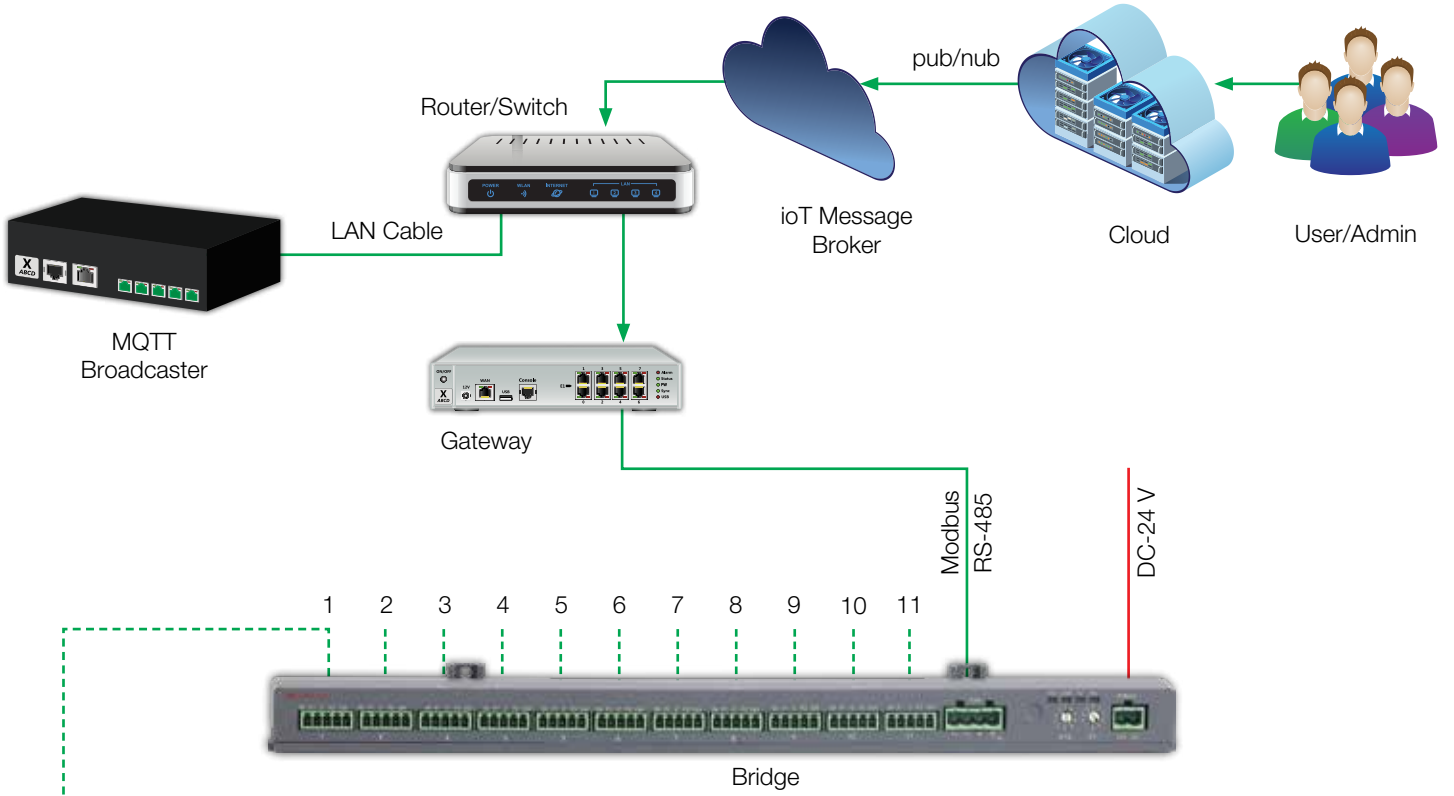

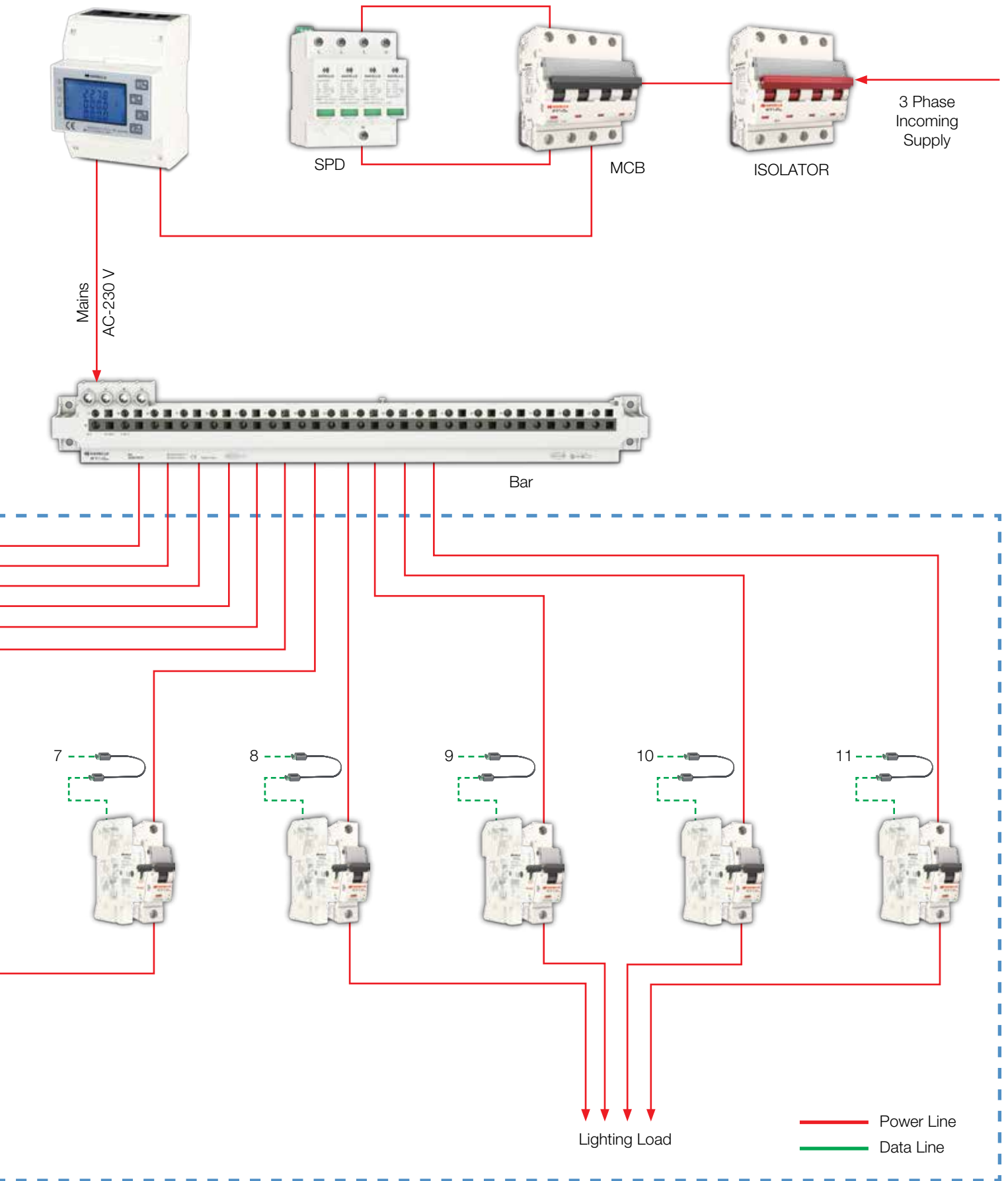



# SHOPPING MALL





## Benefits:

- 1. Expense minimisation:** Reduction in electricity expenses through management of lighting or other devices, by optimization related to human presence. The user can perfectly control energy consumption for each zone.
- 2. Optimized investment** with a system designed and operated functions.
- 3. Ensuring occupant comfort** while reducing operating costs, through last detection and pinpointing in the event of a fault detection on an electrical board.

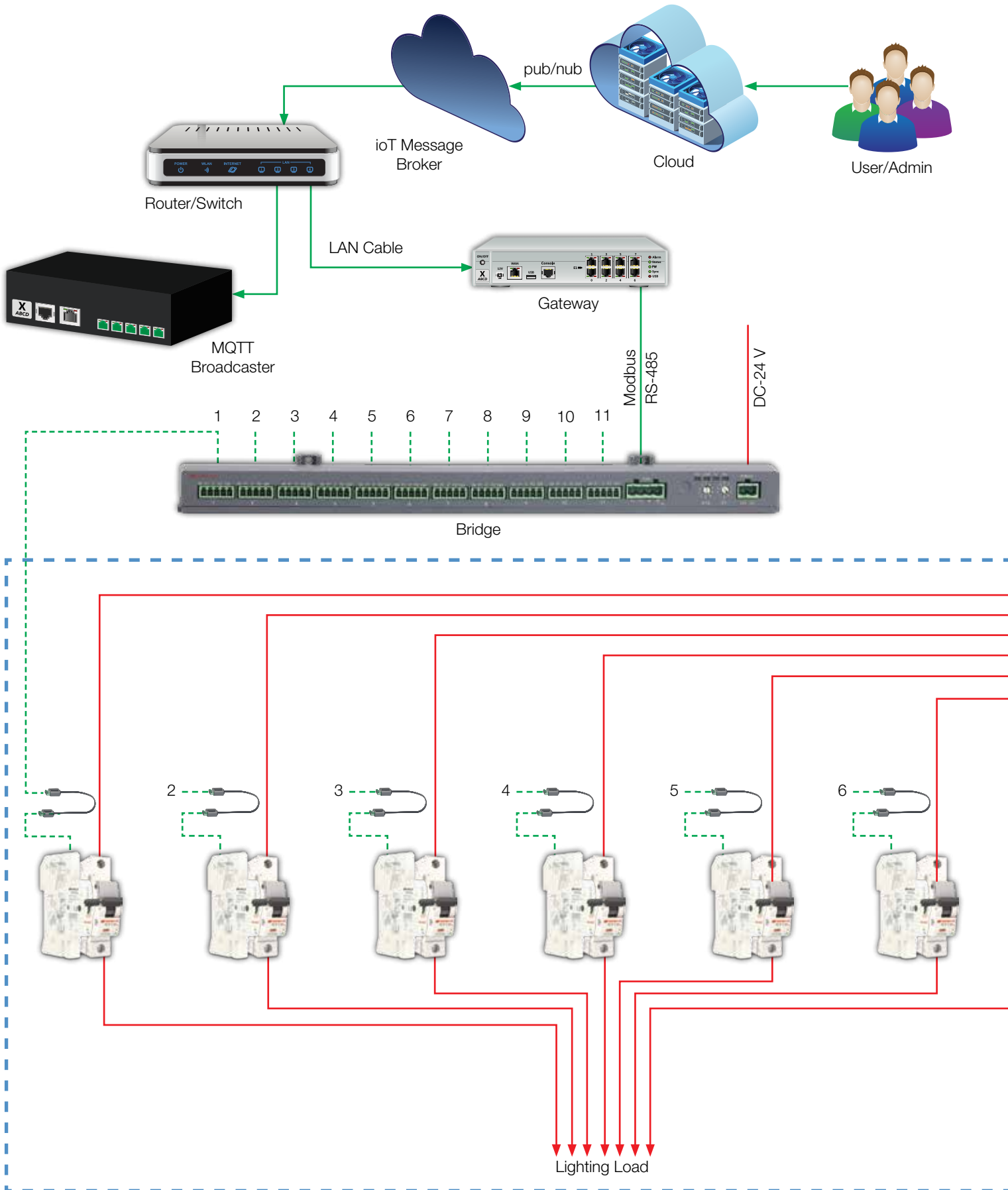

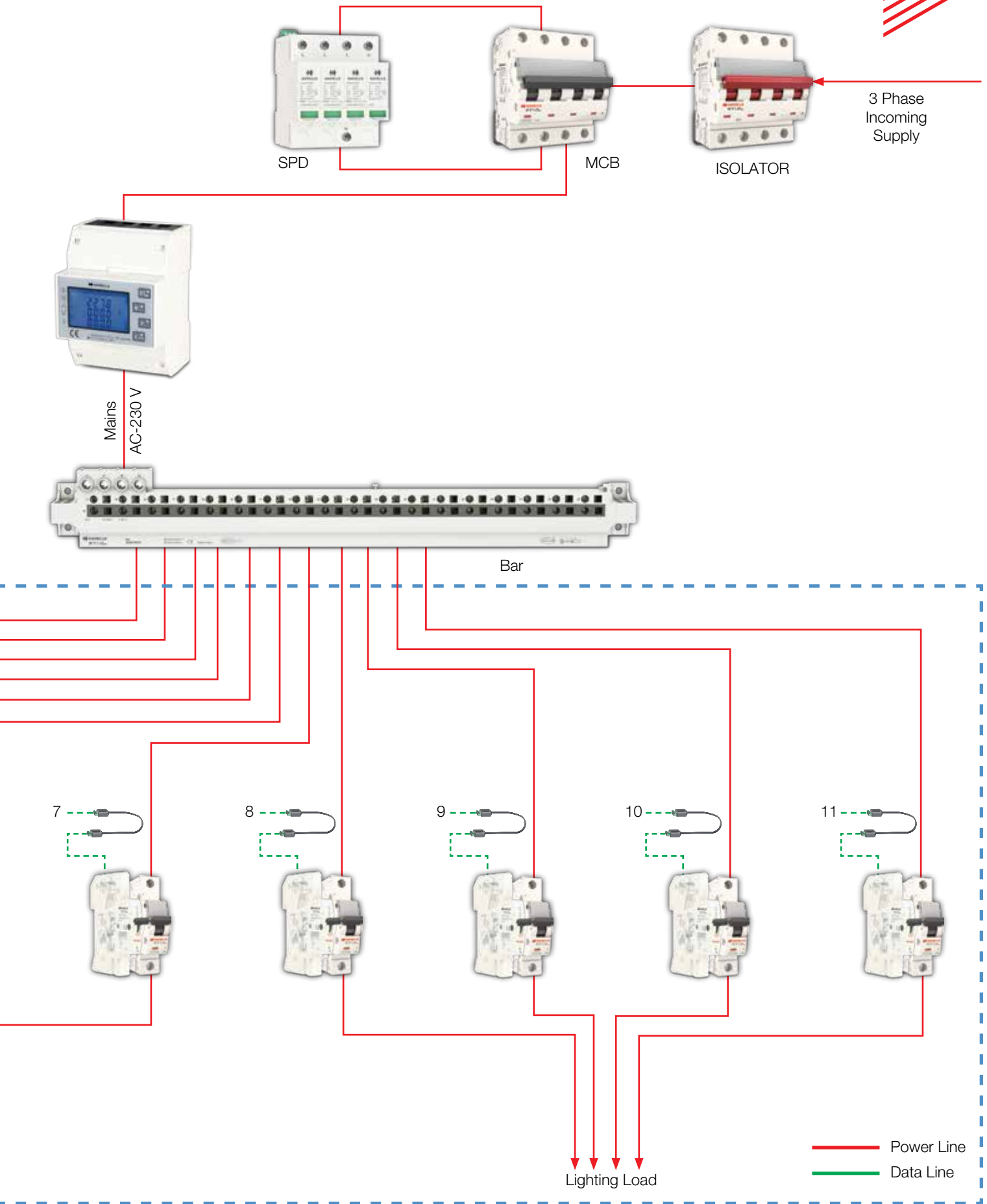



# PARKING LOT





## Benefits:

- 1. Expense minimisation:** Reduction in electricity expenses through management of lighting or other devices, by optimization related to human presence. The user can perfectly control energy consumption for each zone.
- 2. Solution scalability** in the event of reallocation or addition of zones. Bridge solution allows fast and reliable changes for efficient connections with minimal wiring in the distribution board.
- 3. Ensuring occupant comfort** while reducing operating costs, through last detection and pinpointing in the event of a fault detection on an electrical board.

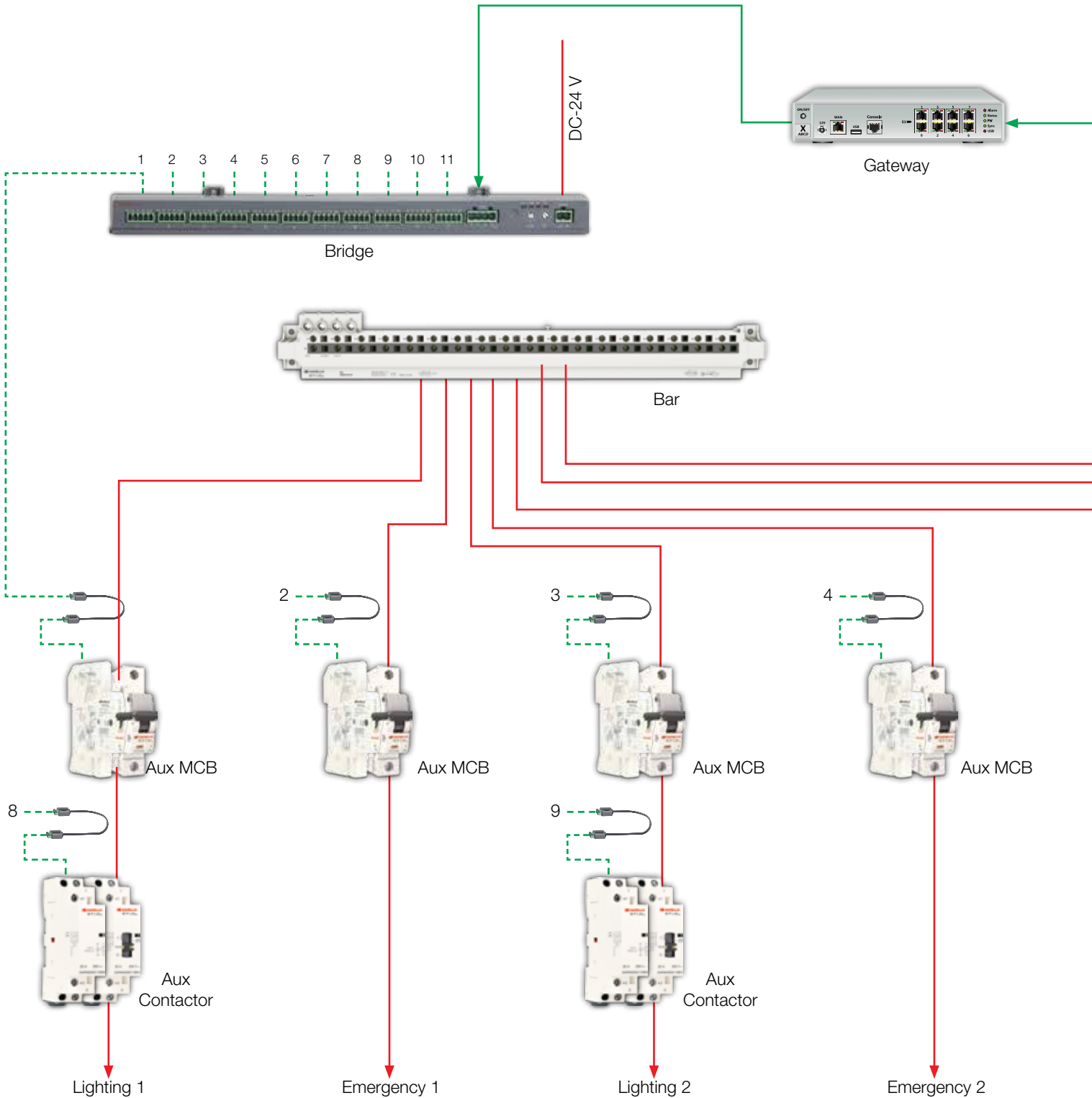

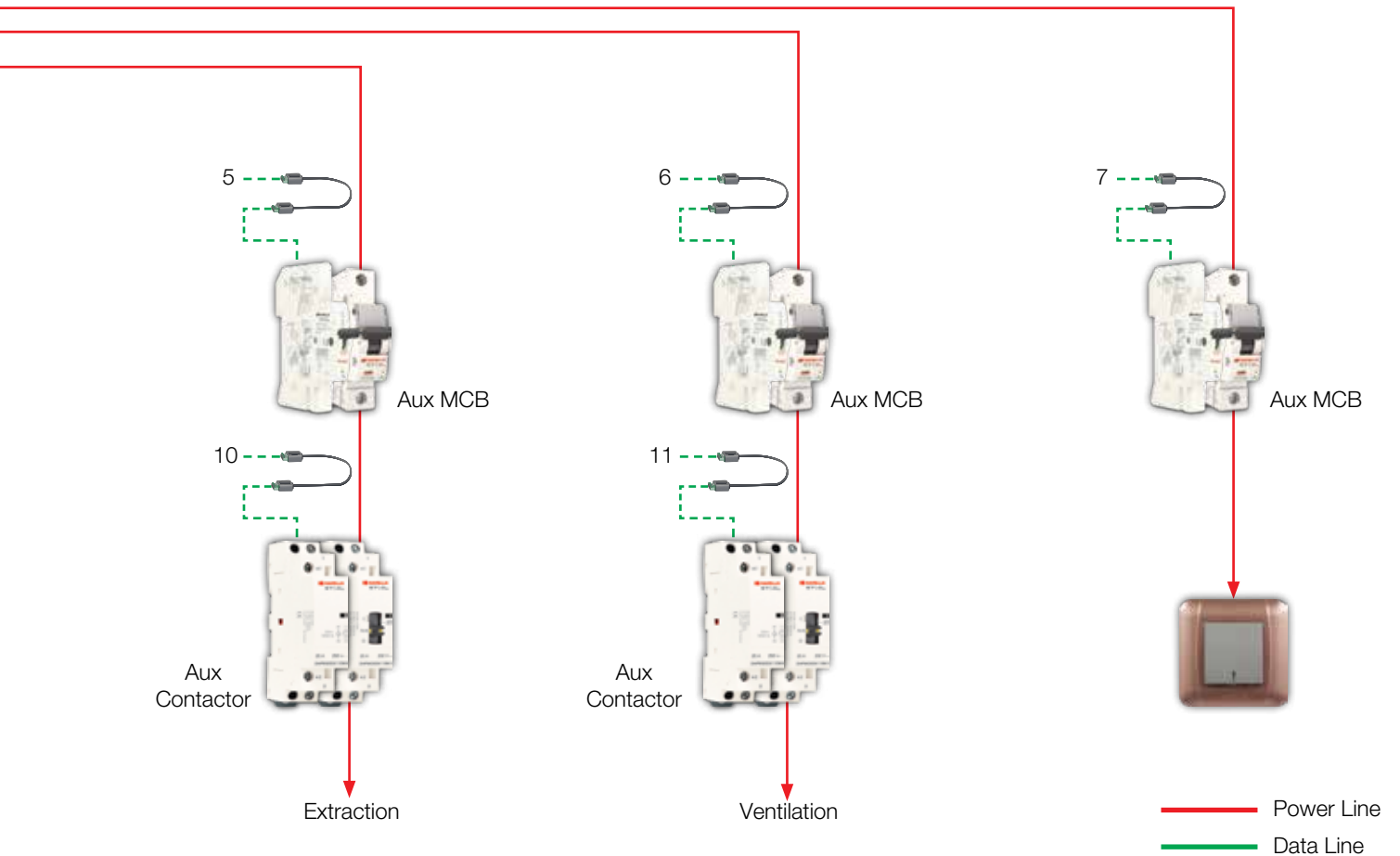
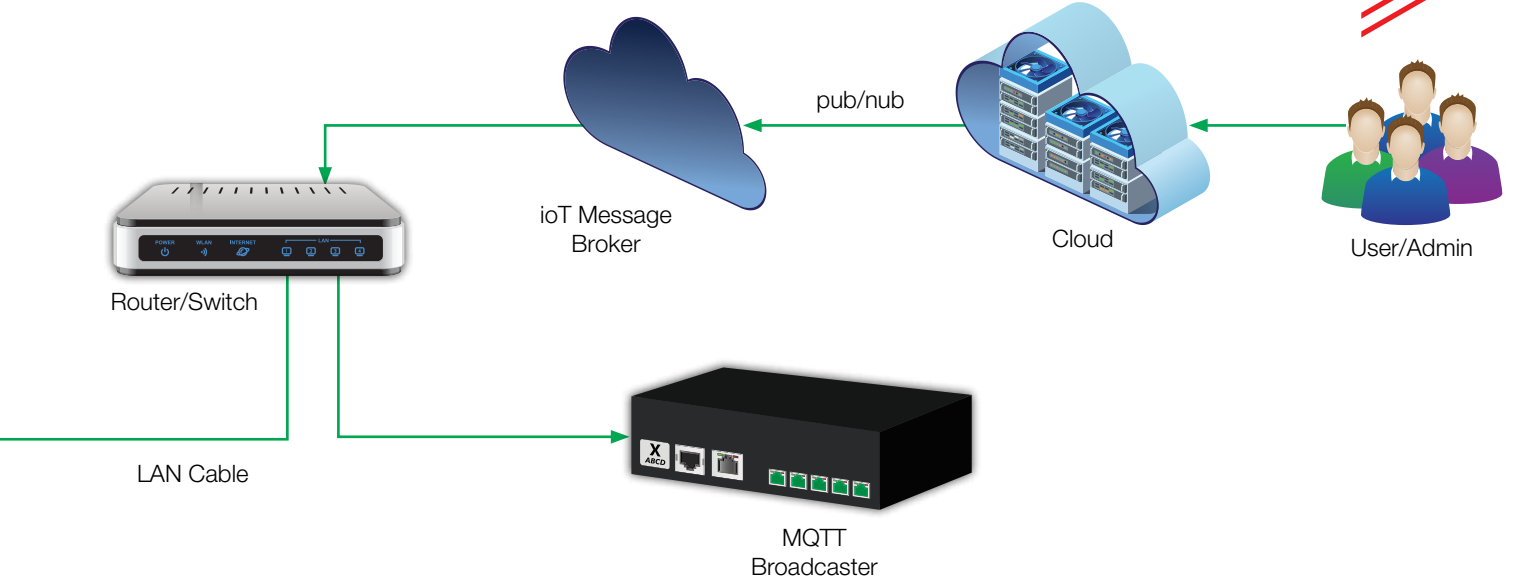

# Product Codes







## STADx Bridge

Description	Cat. No.
STADx Bridge Wired	DHBRIPAV
STADx Bridge Wireless	DHBWIPAV

## Aux MCB & RCCB



Description	Cat. No.
STADx Aux MCB Ax	DHBZFNAX000
STADx Aux MCB Ax+AI	DHBZJNAX000
STADx Aux MCB AI	DHBZGNAX000
STADx Aux RCCB Ax	DHBZFNNN000000
STADx Aux RCCB Ax+AI	DHBZJNNN000000
STADx Aux RCCB AI	DHBZGNNN000000



## Aux Contactor

Description	Cat. No.
STADx Aux contactor	DHZPN000000N

## Recloser MCB & RCCB



Description	Cat. No.
STADx Auto Recloser MCB SP	DHBZMNAX000
STADx Auto Recloser MCB MP	DHBZPNAX000
STADx Auto Recloser RCCB	DHBZRNNN000000

## Aux MCCB



Description	Cat. No.
STADx Aux MCCB	DHBTMNNV





## STADx Dongle

Description	Cat. No.
STADx Dongle Wired	DHBQNUF
STADx Dongle Wireless	DHBSNUF
STADx Extend	DHBPNUF
STADx Transmuter	DHBCNUF



## STADx Energy Meters

Description	Cat. No.
STADx Energy Meter 1P 1M	DHMBSSN045
STADx Energy Meter 1P 2M	DHMBDSN100
STADx Energy Meter 3P	DHMBDTN100



## Accessories

Description	Cat. No.
STADx Wire set 870 dual connector	DSSRCX0188
STADx Wire set 870 single connector	DSSRCX0189
STADx Wire set 160 dual connector	DSSRCX0190



## STADx Bar

Description	Cat. No.
STADx Bar	DSSRCX0187



## Arc Fault Detection Device

Description	Cat. No.
16 A Combined AFDD with MCB	DHAZINSNF016
32 A Combined AFDD with MCB	DHAZINSNF032
40 A Combined AFDD with MCB	DHAZINSNF040
16 A/30 mA Combined AFDD with RCBO	DHAZCNSNF016
32 A/30 mA Combined AFDD with RCBO	DHAZCNSNF032
40 A/30 mA Combined AFDD with RCBO	DHAZCNSNF040
16 A/100 mA Combined AFDD with RCBO	DHAZFNSNF016
32 A/100 mA Combined AFDD with RCBO	DHAZFNSNF032
40 A/100 mA Combined AFDD with RCBO	DHAZFNSNF040

## MCB

### 'C' Series MCB

(In accordance with IS/IEC 60898-1 & IS/IEC 60947-2) 240 V/415 V, 50 Hz, 10 kA.

Rating	SP Cat. No.	SPN Cat. No.	DP Cat. No.
0.5 A-5 A	DHMZCSPF0x5-005	DHMZCSNF0x5-005	DHMZCDPF0x5-005
6 A-32 A	DHMZCSPF006-032	DHMZCSNF006-032	DHMZCDPF006-032
40 A	DHMZCSPF040	DHMZCSNF040	DHMZCDPF040
50 A	DHMZCSPF050	DHMZCSNF050	DHMZCDPF050
63 A	DHMZCSPF063	DHMZCSNF063	DHMZCDPF063
Rating	TP Cat. No.	TPN Cat. No.	FP Cat. No.
0.5 A-5 A	DHMZCTPF0x5-005	DHMZCTNF0x5-005	DHMZCFPF0x5-005
6 A-32 A	DHMZCTPF006-032	DHMZCTNF006-032	DHMZCFPF006-032
40 A	DHMZCTPF040	DHMZCTNF040	DHMZGCFPF040
50 A	DHMZCTPF050	DHMZCTNF050	DHMZCFPF050
63 A	DHMZCTPF063	DHMZCTNF063	DHMZCFPF063



### 'DC' Series MCB

(In accordance with IEC 60947-2) Suitable for 500 V dc & 1000 V dc applications.

Rating	2P 500 V dc Cat. No.	4P 1000 V dc Cat. No.
16 A	DHMZEDPF016	DHMZEFPF016
20 A	DHMZEDPF020	DHMZEFPF020
25 A	DHMZEDPF025	DHMZEFPF025
32 A	DHMZEDPF032	DHMZEFPF032
40 A	DHMZEDPF040	DHMZEFPF040
50 A	DHMZEDPF050	DHMZEFPF050
63 A	DHMZEDPF063	-

## SUPPORT MODULES

### Auxiliary Contact

In accordance with IS/IEC 60947-5-1, 240 V, 50 Hz

CODE	DESCRIPTION
DHMAHSPF006	1NO + 1NC (MCB)
DHRXGN000000	1NO + 1NC (RCCB-D7)

### Shunt Trip

In accordance with IS/IEC 60947-3-1, 240 V, 50 Hz

CODE	RATING
DHMZNP1X0002110	12 V
DHMZNP1X0002200	24 V
DHMZNP1X0002310	48 V
DHMZNP1X0002400	110 V ac - 415 V ac, 110 V dc - 130 V dc

### Under Voltage / Over Voltage

CODE	DESCRIPTION
DHMZNP1X0003510	OVT Single Phase 240 V ac STADx
DHMZNP3X0003510	OVT Three Phase 240 V ac STADx
DHM2NP1X0003310	Phase Loss STADx
DHMZNP1X0003110	UVT Single Phase 240 V ac
DHMZNP1X0004110	UVT-OVT 1 Phase 240 V ac
DHMZNP3X0004110	UVT-OVT 3 Phase 240 V ac
DHMZNP1X0003210	UVT delay 1 Phase 240 V ac
DHMZNP3X0003210	UVT delay 3 Phase 240 V ac



Higher Rating MCB (80 to 125A) 'C' Series,  
(In accordance with IEC 60947-2) 240 V/415 V, 50 Hz, 10 kA

Rating	SP Cat. No.	DP Cat. No.	TP Cat. No.	FP Cat. No.
80 A	DHMZCSPF080	DHMZCDPF080	DHMZCTPF080	DHMZCFPF080
100 A	DHMZCSPF100	DHMZCDPF100	DHMZCTPF100	DHMZCFPF100
125 A	DHMZCSPF125	DHMZCDPF125	DHMZCTPF125	DHMZCFPF125

## RCCB

RCCB - 'AC' Type

(In accordance with IS 12640-1 & IEC 61008-1) 240 V/415 V, 50 Hz with 10 kA short circuit withstand capacity

Rating (DP)	30 mA Cat. No.	100 mA Cat. No.	300 mA Cat. No.
16 A	DHRXCMDF030016	DHRXCMDF100016	DHRXCMDF300016
25 A	DHRXCMDF030025	DHRXCMDF100025	DHRXCMDF300025
32 A	DHRXCMDF030032	DHRXCMDF100032	DHRXCMDF300032
40 A	DHRXCMDF030040	DHRXCMDF100040	DHRXCMDF300040
63 A	DHRXCMDF030063	DHRXCMDF100063	DHRXCMDF300063
80 A	DHRXCMDF030080	DHRXCMDF100080	DHRXCMDF300080
100 A	DHRXCMDF030100	DHRXCMDF100100	DHRXCMDF300100
Rating (FP)	30 mA Cat. No.	100 mA Cat. No.	300 mA Cat. No.
16 A	DHRXCMFF030016	DHRXCMFF100016	DHRXCMFF300016
25 A	DHRXCMFF030025	DHRXCMFF100025	DHRXCMFF300025
32 A	DHRXCMFF030032	DHRXCMFF100032	DHRXCMFF300032
40 A	DHRXCMFF030040	DHRXCMFF100040	DHRXCMFF300040
63 A	DHRXCMFF030063	DHRXCMFF100063	DHRXCMFF300063
80 A	DHRXCMFF030080	DHRXCMFF100080	DHRXCMFF300080
100 A	DHRXCMFF030100	DHRXCMFF100100	DHRXCMFF300100



RCCB - 'HLI' Type

(In accordance with IS 12640-1 & IEC 61008-1) 240 V/415 V, 50 Hz with 10 kA short circuit withstand capacity  
Suitable for AC + Pulsating DC (Type A) + Harmonics

Rating (DP)	30 mA Cat. No.	100 mA Cat. No.	300 mA Cat. No.
40 A	DHRZDTDF030040	DHRZDTDF100040	DHRZDTDF300040
63 A	DHRZDTDF030063	DHRZDTDF100063	DHRZDTDF300063
Rating (FP)	30 mA Cat. No.	100 mA Cat. No.	300 mA Cat. No.
40 A	DHRZDTFF030040	DHRZDTFF100040	DHRZDTFF300040
63 A	DHRZDTFF030063	DHRZDTFF100063	DHRZDTFF300063



## RCBO

Electromechanical 2 P RCBOs used as (SPN & 2 P RCBOs)

(In accordance with IS 12640-2 & IEC 61009-1) 240 V/415 V, 50 Hz, with 10 kA short circuit capacity

Rating (SPN)	30 mA Cat. No.	100 mA Cat. No.	300 mA Cat. No.
16 A	DHBMACDP4030016	DHBMACDP4100016	DHBMACDP4300016
25 A	DHBMACDP4030025	DHBMACDP4100025	DHBMACDP4300025
32 A	DHBMACDP4030032	DHBMACDP4100032	DHBMACDP4300032
40 A	DHBMACDP4030040	DHBMACDP4100040	DHBMACDP4300040
63 A	DHBMACDP4030063	DHBMACDP4100063	DHBMACDP4300063



Electromechanical 4P RCBOs used as (TPN & FP RCBOs)

(In accordance with IS 12640-2 & IEC 61009-1) 240 V/415 V, 50 Hz, with 10 kA short circuit capacity

Rating (TPN)	30 mA Cat. No.	100 mA Cat. No.	300 mA Cat. No.
16 A	DHBMACTN8030016	DHBMACTN8100016	DHBMACTN8300016
25 A	DHBMACTN8030025	DHBMACTN8100025	DHBMACTN8300025
32 A	DHBMACTN8030032	DHBMACTN8100032	DHBMACTN8300032
40 A	DHBMACTN8030040	DHBMACTN8100040	DHBMACTN8300040
63 A	DHBMACTN8030063	DHBMACTN8100063	DHBMACTN8300063



## SPD

### Type 1+2 AC Surge Protection Device

Order Code	Poles	Uc (V)	In (kA)	Iimp (kA)	I <sub>max</sub> (kA)	Up (kV)	Remote Signaling
DHSAARBC50320	TP+N	320	20	12.5	50	1.5	Yes
DHSAARAC50320	1P+N	320	20	12.5	50	1.5	Yes

### Cartridges

Order Code	Pole	Uc (V)	In (kA)	Iimp (kA)	I <sub>max</sub> (kA)	Up (kV)
DSSRCX0149	L - N	320	20	12.5	50	1.5
DSSRCX0150	N - PE	255	40	12.5	70	1.5

### Type 2 AC Surge Protection Device

Order Code	Poles	Uc (V)	In (kA)	I <sub>max</sub> (kA)	Up (kV)	Remote Signaling
DHSA2NAN40320	1P+N	320	20	40	1.5	No
DHSA2NBN40320	TP+N	320	20	40	1.5	No

### Cartridges

Order Code	Pole	Uc (V)	In (kA)	I <sub>max</sub> (kA)	Up (kV)
DSSRCX0151	L - N	320	20	40	1.5
DSSRCX0152	L - N	275	20	40	1.3
DSSRCX0153	N - PE	255	20	40	1.5

### Surge Protection Adaptor Type 3

Order Code	Uc <sub>pv</sub> (V)	In (kA)	I <sub>max</sub> (kA)	Up (kV)	Uoc (kV)
DHAA3NMA10230	320 V dc	5	10	1.5	6

### Type 1+2 Photovoltaic Surge Protection Device

Order Code	Uc <sub>pv</sub> (V)	In (kA)	Iimp (kA)	I <sub>max</sub> (kA)	Up (kV)	Remote Signaling
DHSDARCC6012H	1200 V dc	20	12.5	60	4	Yes
DHSDARCB4012H	1200 V dc	20	6	40	4	Yes

### Cartridges

Order Code	Pole	Uc <sub>pv</sub> (V)	In (kA)	Iimp (kA)	I <sub>max</sub> (kA)	Up (kV)
DSSRCX0154	-	1200 V dc	20	6	40	4

### Type 2 Photovoltaic Surge Protection Device

Order Code	Uc <sub>pv</sub> (V)	In (kA)	I <sub>max</sub> (kA)	Up (kV)	Remote Signaling
DHSD2NCN4012H	1200 V dc	20	40	4	No

### Cartridges

Order Code	Pole	Uc <sub>pv</sub> (V)	In (kA)	I <sub>max</sub> (kA)	Up (kV)
DSSRCX0155	-	1200 V dc	20	40	4

### Type 2 DC 600 V Surge Protection Device

Order Code	Uc <sub>pv</sub> (V)	In (kA)	I <sub>max</sub> (kA)	Up (kV)	Remote Signaling
DHSD2N2N40600	600 V dc	20	40	4	No



## TIME SWITCH



Description	Cat. No.
24 Hour Analog Time Switch (SST* - 15 min)	DHTED15016
24 Hour Analog Time Switch (SST* - 30 min)	DHTED30016
Astronomical + Digital Time Switch-3 years	DHTQB01016
Digital Weekly time switch-3 years	DHTJW01016

\* Shortest Switching Time

## MCB Isolator

MCB ISOLATOR (Switching Devices)

MCB Isolators (AC-22 A, In accordance with IS/IEC 60947-3) 240 V/415 V, 50 Hz



Rating	SP Cat. No.	DP Cat. No.
40 A	-	DHMZIDPX040
63 A	-	DHMZIDPX063
100 A	-	DHMZIDPX100
125 A	-	DHMZIDPX125
Rating	TP Cat. No.	FP Cat. No.
40 A	DHMZITPX040	DHMZIFPX040
63 A	DHMZITPX063	DHMZIFPX063
100 A	DHMZITPX100	DHMZIFPX100
125 A	DHMZITPX125	DHMZIFPX125

## ACCL

3 Module SPN ACCL (Automatic Source Changeover with Current Limiter)



Mains Rating	Gen Rating	Product Code	Description
SPN 30 (6000 W)	SPN 1.5 (300 W)	DHADOSN301X	30 A/1.5 A ACCL W/O GEN START/STOP
SPN 30 (6000 W)	SPN 2.5 (500 W)	DHADOSN302X	30 A/2.5 A ACCL W/O GEN START/STOP
SPN 30 (6000 W)	SPN 3 (600 W)	DHADOSN3003	30 A/03 A ACCL W/O GEN START/STOP
SPN 30 (6000 W)	SPN 4 (800 W)	DHADOSN3004	30 A/4 A ACCL W/O GEN START/STOP
SPN 30 (6000 W)	SPN 5 (1000 W)	DHADOSN3005	30 A/5 A ACCL W/O GEN START/STOP
SPN 30 (6000 W)	SPN 6 (1200 W)	DHADOSN3006	30 A/06 A ACCL W/O GEN START/STOP
SPN 30 (6000 W)	SPN 9 (1800 W)	DHADOSN3009	30 A/09 A ACCL W/O GEN START/STOP
SPN 30 (6000 W)	SPN 12 (2400 W)	DHADOSN3012	30 A/12 A ACCL W/O GEN START/STOP
SPN 30 (6000 W)	SPN 15 (3000 W)	DHADOSN3015	30 A/15 A ACCL W/O GEN START/STOP
SPN 30 (6000 W)	SPN 20 (4000 W)	DHADOSN3020	30 A/20 A ACCL W/O GEN START/STOP



Automatic Changeover

Mains & Gen Rating	Cat. No. w/o GEN Start/Stop	Description
SPN 30 (6000 W)	DHATOSN3030	SPN 30 (6000 W)
SPN 63 (12600 W)	DHAAOSN6363	SPN 63 (12600 W)



TPN ACCL (TPN/SPN) (Automatic Source Changeover with Current Limiter)

Mains Rating	Gen Rating	Description	Cat. No.
40 A	30 A	40 A/30 A TPN/SPN ACCL	DHACOTN4030
63 A	30 A	63 A/30 A TPN/SPN ACCL	DHACOTN6330
63 A	40 A	63 A/40 A TPN/SPN ACCL	DHACOTN6340



TPN ACCL (TPN/TPN) (Automatic Source Changeover with Current Limiter)

Mains Rating	Gen Rating	Description	Cat. No.
40 A	30 A	40 A/30 A TPN/TPN ACCL	DHACOTT4030
40 A	40 A	40 A/40 A TPN/TPN ACCL	DHACOTT4040
63 A	40 A	63 A/40 A TPN/TPN ACCL	DHACOTT6340
63 A	63 A	63 A/63 A TPN/TPN ACCL	DHACOTT6363
80 A	63 A	80 A/63 A TPN/TPN ACCL	DHACOTT8063
80 A	80 A	80 A/80 A TPN/TPN ACCL	DHACOTT8080



## AUTOMATIC MODULAR CONTACTORS WITH MANUAL OVERRIDE

Automatic Modular Contactors with Manual Override - SP (Applicable Standard - IEC 61095)

Poles	Rating AC-7a	Number of Contacts	Width in multiples of 1 module (18 mm)	Product Code
1 P	25 A	1 NO	1	DHPMG025110M



Automatic Modular Contactors with Manual Override - DP (Applicable Standard - IEC 61095)

Poles	Rating AC-7a	Number of Contacts	Width in multiples of 1 module (18 mm)	Product Code
2 P	16 A	2 NO	1	DHPMF016120M
2 P	25 A	2 NO	1	DHPMF025120M
2 P	40 A	2 NO	2	DHPMF040220M
2 P	63 A	2 NO	2	DHPMF063220M



Automatic Modular Contactors with Manual Override - TP (Applicable Standard - IEC 61095)

Poles	Rating AC-7a	Number of Contacts	Width in multiples of 1 module (18 mm)	Product Code
3 P	25 A	3 NO	2	DHPMA025230M
3 P	40 A	3 NO	3	DHPMA040330M
3 P	63 A	3 NO	3	DHPMA063330M



Automatic Modular Contactors with Manual Override - FP (Applicable Standard - IEC 61095)

Poles	Rating AC-7a	Number of Contacts	Width in multiples of 1 module (18 mm)	Product Code
4 P	25 A	4 NO	2	DHPMC025240M
4 P	40 A	4 NO	3	DHPMC040340M
4 P	63 A	4 NO	3	DHPMC063340M

## DISTRIBUTION BOARD - IP 43

SPN IP 43 Distribution Boards  
The New Style Statement for your DBs

No. of Ways	SPN Cat. No.	Material Description
6 Ways	DHDESHCDOW06	SPN 6 Ways DD DB STADX - IP43
8 Ways	DHDESHCDOW08	SPN 8 Ways DD DB STADX - IP43
12 Ways	DHDESHCDOW12	SPN 12 Ways DD DB STADX - IP43
16 Ways	DHDESHCDOW16	SPN 16 Ways DD DB STADX - IP43

TPN IP 43 Distribution Boards  
Suitable for MCB / RCCB / Isolator as incomer

No. of Ways	I/C+O/G	TPN Cat. No.	Material Description
4 Ways ECO	4+12	DHDETHCDOW04	TPN 4 Ways DD DB STADX - IP43 Eco
4 Ways	8+12	DHDETHCDOW48	TPN 4 Ways DD DB STADX - IP43
6 Ways	8+18	DHDETHCDOW06	TPN 6 Ways DD DB STADX - IP43
8 Ways	8+24	DHDETHCDOW08	TPN 8 Ways DD DB STADX - IP43
12 Ways	8+36	DHDETHCDOW12	TPN 12 Ways DD DB STADX - IP43

IP 43 Flexi Tier DD Distribution Board

No. of Ways	Cat. No.	Material Description
2T24M	DHDMTVZDXW12	2 TIER 24 MODULE DD DB STADx
3T36M	DHDMTVYDXW12	3 TIER 36 MODULE DD DB STADx
4T40M	DHDMTVXDXW10	4 TIER 40 MODULE DD DB STADx
4T56M	DHDMTVXDXW14	4 TIER 56 MODULE DD DB STADx

IP 43 Vertical Phase Selector Distribution Board

No. of Ways	Cat. No.	Material Description
4 Ways	DHDSMVDOZ04040	DB PH- SEL 4 Ways DD 40A VERT STADx
4 Ways	DHDSMVDOZ04063	DB PH- SEL 4 Ways DD 63A VERT STADx
6 Ways	DHDSMVDOZ06040	DB PH- SEL 6 Ways DD 40A VERT STADx
6 Ways	DHDSMVDOZ06063	DB PH- SEL 6 Ways DD 63A VERT STADx
8 Ways	DHDSMVDOZ08040	DB PH- SEL 8 Ways DD 40A VERT STADx
8 Ways	DHDSMVDOZ08063	DB PH- SEL 8 Ways DD 63A VERT STADx

IP 43 PPI TPN Horizontal Distribution Board

No. of Ways	Cat. No.	Material Description
4 Ways	DHDMTHPDOW04	2+4 Ways PPI Horizontal DD DB STADx
6 Ways	DHDMTHPDOW06	2+6 Ways PPI Horizontal DD DB STADx
8 Ways	DHDMTHPDOW08	2+8 Ways PPI Horizontal DD DB STADx
12 Ways	DHDMTHPDOW12	2+12 Ways PPI Horizontal DD DB STADx



IP 43 Phase Segregated 8 Segment Distribution Board

No. of Ways	Cat. No.	Material Description
4 Ways	DHDMTHDDOW04	8 Segment 4 Ways DD DB STADx
6 Ways	DHDMTHDDOW06	8 Segment 6 Ways DD DB STADx
8 Ways	DHDMTHDDOW08	8 Segment 8 Ways DD DB STADx
12 Ways	DHDMTHDDOW12	8 Segment 12 Ways DD DB STADx



IP 43 VTPN Modular Incomer Distribution Board

No. of Ways	Cat. No.	Material Description
4 Ways	DHDMTVODCW04	TPN VERTICAL 4 Ways DD DB STADx
6 Ways	DHDMTVODCW06	TPN VERTICAL 6 Ways DD DB STADx
8 Ways	DHDMTVODCW08	TPN VERTICAL 8 Ways DD DB STADx
12 Ways	DHDMTVODCW12	TPN VERTICAL 12 Ways DD DB STADx



IP 43 VTPN With MCCB Incomer Distribution Board

No. of Ways	Cat. No.	Material Description
4 Ways	DHDLVDOBGSFE04	TPN VERTICAL LL 160 A 4 Ways DD DB STADx
6 Ways	DHDLVDOBGSFE06	TPN VERTICAL LL 160 A 6 Ways DD DB STADx
8 Ways	DHDLVDOBGSFE08	TPN VERTICAL LL 160 A 8 Ways DD DB STADx
12 Ways	DHDLVDOBGSFE12	TPN VERTICAL LL 160 A 12 Ways DD DB STADx

No. of Ways	Cat. No.	Material Description
4 Ways	DHDLVDOBASF04	TPN VERTICAL LL 250 A 4 Ways DD DB STADx
6 Ways	DHDLVDOBASF06	TPN VERTICAL LL 250 A 6 Ways DD DB STADx
8 Ways	DHDLVDOBASF08	TPN VERTICAL LL 250 A 8 Ways DD DB STADx
12 Ways	DHDLVDOBASF12	TPN VERTICAL LL 250 A 12 Ways DD DB STADx



## COMMUNICATION DB

Cat. No.	Material Description
DHDMTVPCW24	TPN 1ROW 24 Ways DD DB
DHDMTVZCW24	TPN 2ROW 24 Ways DD DB
DHDMTVYDCW24	TPN 3ROW 24 Ways DD DB
DHDMTVXDCW24	TPN 4ROW 24 Ways DD DB









#### REGIONAL & BRANCH OFFICES:

**NORTH - REGIONAL OFFICE: Corporate Office:** QRG Towers, 2D, Sector-126, Expressway, Noida-201304, Tel: 0120-3331000, **Delhi:** Tel: 011-47676700, 23888200, **Chandigarh:** Tel: 0172-4232400-401, **Dehradun:** Tel: 0135-6670202, **Haldwani:** Tel: 05946-222935/222933, **Noida / Haryana:** Tel: 0120-3331000, **Ludhiana:** Tel: 0161-4676000 / 24, **Amritsar:** Tel: 0183-5202400/401, **Jammu:** Tel: 0191-2478330, 2479330, **Sri Nagar:** Tel: 0194-2490431, **Jaipur:** Tel: 0141-3914645, 3988210 **Jodhpur:** Tel: 0291-9214201640 / 45, **Lucknow:** Tel: 0522-6672100, **Kanpur:** Tel: 0512-6710400, 6710409

**EAST - REGIONAL OFFICE: Kolkata:** ICC Tower, 5th Floor, 4 India Exchange Place, Kolkata-700001, Tel: 033-40129851 / 52, **Bhubaneswar:** Tel: 0674-6668101/102/103/104, **Guwahati:** Tel: 0361-2134521, 2458923, 2460355, **Siliguri:** Tel: 0353-2525907, **Ranchi:** 0651-2244861, 2244862, 2244864, 2244868, 2244869, **Jamshedpur:** Tel: 0657-6542492, 09234369436, **Patna:** Tel: 0612-2207221, 2207222, 2207223, 2655518

**WEST - REGIONAL OFFICE: Mumbai:** 14th Floor, Unit No. 1405- 1408, Lodha Supremus, I- Think Techno Campus, Kanjurmarg East, Mumbai- 400 042. Ph.: 022 - 67298600-601, **Ahmedabad:** Tel: 079-40061111, 40060738-740, **Indore:** Tel: 0731-2572340-41, 4009998 (Airtel), **Rajkot:** Tel: 0281-2481112, 2921212, **Nagpur:** Tel: 0712-2240932, 2242692, 2242699 **Pune:** Tel: 020-64016413 / 14, **Raipur:** Tel: 0771-4243400 / 01, **Surat:** Tel: 0261-2350137, 9979890137, **Jabalpur:** Tel: 0761-4064491, **Bhopal:** 0755-4271544, 0755-4011025

**SOUTH - REGIONAL OFFICE: Chennai:** Khivraj Complex -1, 1st Floor, No.480, Annasalai, Nandanam, Chennai – 600035 Phone: 044: 42280600, **Bangalore:** Tel: 080-49075000, **Coimbatore:** Phone: 0422- 4550200 / 287, **Hyderabad:** Tel: 040-27533372, 27533355, 27533632, 66320407/0408/6401/6402, **Kochi:** Tel: 0484-4099000, **Vizag:** Tel: 0891-6514339, **Vijayawada:** Tel: +91-9247058847/57, **Calicut:** 0495-4019194, **Trivandrum:** 0471-4015323, **Hubli:** 09448146028

**Representative Offices:** • Goa • Solapur • Gwalior • Kathmandu • Kolhapur • Vadodara

Actual products may vary in colour, design, description and colour combination etc.

Although every effort has been made to ensure accuracy in the compilation of the technical detail within this publication. Specifications & performance data are constantly changing. Current details should therefore be checked with Havells Group.

Scan the QR Code  
to download  
Havells mCatalogue



#### Havells India Ltd.

Corp Office: QRG Towers, 2D, Sector-126, Expressway, Noida-201304 (U.P.)  
Ph. +91-120-3331000, Email: marketing@havells.com, www.havells.com  
Customer Care No.: 08045 77 1313

Join us on Facebook at [www.facebook.com/havells](http://www.facebook.com/havells) and share your ways to save planet!  
CIN - L31900DL1983PLC016304

Copyright Subsists. Imitation of trade dress, graphics and color scheme of this document is a punishable offence.



# HAVELLS